

BRASSTECH		2001 E. CARNEGIE AVE.	
INCORPORATED		SANTA ANA, CA 92705	
DWG NO.		REV	
1030-5603		D	
SCALE .300	REF. -	SHEET 2 OF 3	

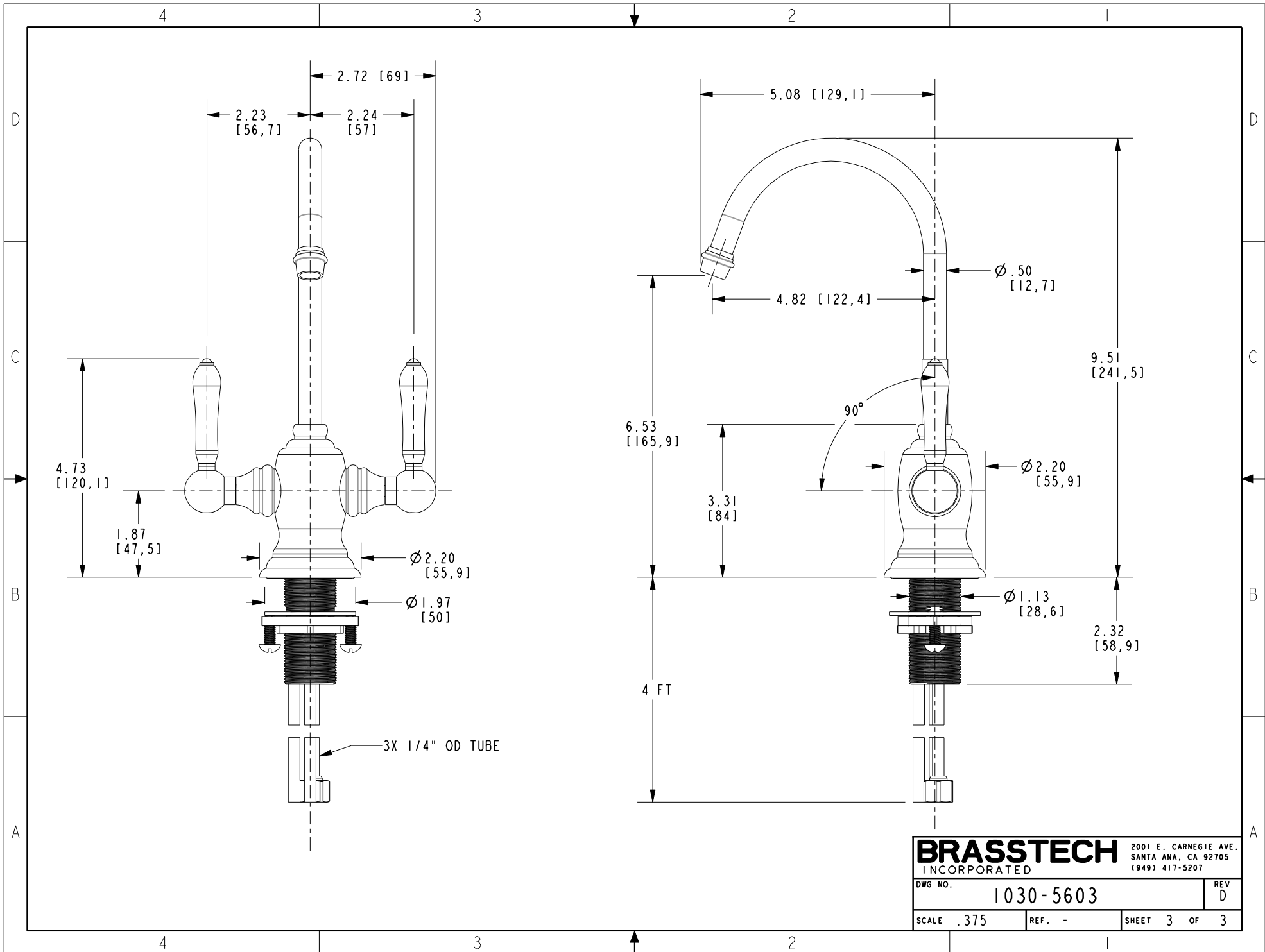

BRASSTECH		2001 E. CARNEGIE AVE.	
INCORPORATED		SANTA ANA, CA 92705	
DWG NO. 1030-5603		REV D	
SCALE .375	REF. -	SHEET 3 OF 3	