

4

3

2

1

NOTES:

- (N1) 1. FIT / FORM / FUNCTION SHALL FOLLOW PS-E.008.
 2 CUT AND SHORTEN O-RING BY .13" TO .20" IN LENGTH BEFORE INSTALLING.
 3 SLIT O-RING BEFORE INSTALLING.
 4 APPLY LOCTITE 242.
 (N5) 5 CONNECT WHITE AND RED TUBINGS TOGETHER AND WATER TEST WHOLE UNIT.
 6 BAG 5-035 IN A SEPARATE BAG.
 (N7) 7 REWORK CARTRIDGE ASSY IF THE HANDLE DOES NOT RETURN TO THE "OFF" POSITION AUTOMATICALLY AFTER WATER TESTING.
 8 INSTALLATION TORQUE: 8-14 LB-FT.
 9 INSTALLATION TORQUE: 78 LB-IN +/- 6 LB-IN
 10 LUBRICATE SPRING WITH DOW CORNING III.
 11 PRE-CRIMPED THESE PARTS TOGETHER. SEE INSTALLATION INSTRUCTION.
 12 APPLY THIN FILM OF DOW CORNING III.
 13 APPLY LOCTITE 680.
 14 INSTALLATION TORQUE 10-14 LB-IN

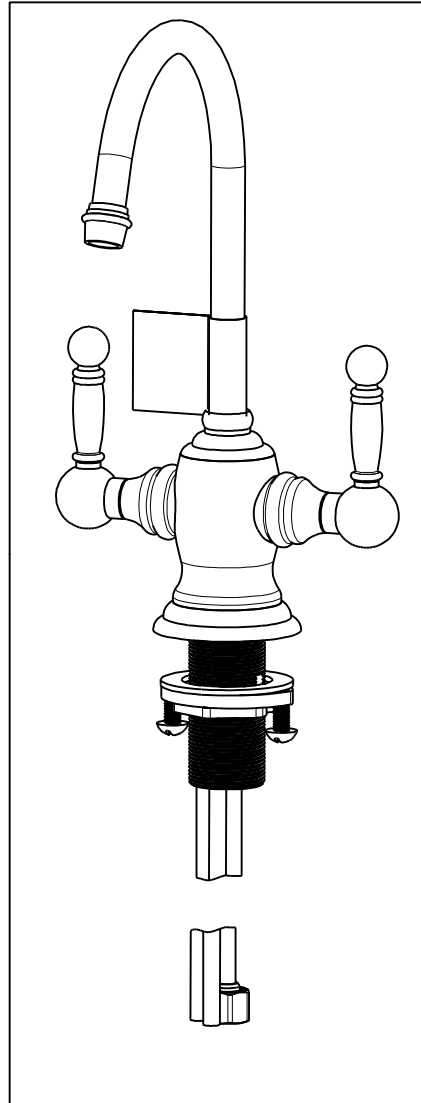

BILL OF MATERIAL (CURRENT LEVEL)

ITEM	PT/ASSY	DESCRIPTION	TYPE	QTY.
1	1-134	CARTR 3/8 HOT 1/4 TR	PART	1
2	1-393	1-1/8 18 UNEF MOUNTING KIT	ASSEMBLY	1
3	1-431	RED SUPPLY LINE	ASSEMBLY	1
4	1-432	BLUE SUPPLY LINE	ASSEMBLY	1
5	1-433	GREY SUPPLY LINE	ASSEMBLY	1
6	5-035	COUPLING & INSERT ASM	ASSEMBLY	1
7	5-061	ADAPTER/CARTRIDGE ASSY	ASSEMBLY	1
8	11833	ADAPTER	PART	1
9	12589	WATER DISP LEVER HUB (TRAD)	PART	2
10	12716	ESCUTCHEON	PART	1
11	13070	RETAINER PLATE	PART	1
12	13282	WATER DISP. BODY H/C (TRAD)	PART	1
13	13289	NIPPLE	PART	1
14	50705	WATER DISP BODY CAP	PART	1
15	50706	WATER DISP SPOUT RET RING	PART	1
16	50708	WATER DISP HDL BONNET (TRAD)	PART	2
17	50711	LEVER HANDLE	PART	2
18	50712	WATER DISP SPOUT SHELL	PART	1
19	50713	SPOUT, WATER DISP. (TRAD.)	PART	1
20	50714	WATER DISP. CAR.T HOLDER	PART	2
21	91017	O-RING, #2- 012, EPDM, 65-75 DURO, NSF 61	PART	2
22	91217	O-RING, #2-020, EPDM, 65-75 DURO, NSF 61	PART	1
23	91373	BLUE IDENTIFIER	PART	1
24	91374	RED IDENTIFIER	PART	1
25	91382	O-RING, #2- 012, TEFLON,	PART	1
26	91383	O-RING, #2- 014, TEFLON, NSF 61	PART	1
27	91762	O-RING, #2-132, EP, 50 DURO - GREY	PART	1
28	92000	SCREW 8 - 32 X 1/8 SS	PART	2
29	92016	SCRW, 10-24 X 3/4 SKT HD FLT PT SS	PART	1
30	92192	SCRW, 10-32 X 5/8 SKT HD CUP PT SS	PART	2
31	92477	SCRW, M4 X 16 SKT FLT HD SS	PART	1
33	98043	TAG LABEL, HOT WATER WARNING	PART	1

-	T	EN-3634A	11/29/19	C.G.
-	R	EN-3558o	05/15/19	C.G.
-	P	EN-3722	02/09/19	C.G.
-	N	EN-3558o	01/03/18	V.V.
-	M	EN-3257D	10/04/17	V.V.
-	L	EN-3205	01/23/17	J.A.
-	K	EN-2601	09/16/13	-
-	J	EN-2528	05/08/13	-
-	H	EN-2235	07/30/12	-
-	G	EN-2186	06/20/12	-
-	F	EN-1675A	12/14/10	-
-	E	EO-0936	01/29/08	-
-	D	EO-0707	05/24/06	-
-	C	EO-0478	02/16/05	-
ZONE	REV	DESCRIPTION	DATE	APPROVED

COPYRIGHT 2005 BRASSTECH, INC. THESE DRAWINGS AND THE DESIGNS DEPICTED HEREIN ARE THE PROPRIETARY PROPERTY OF BRASSTECH. ANY USE OR REPRODUCTION IS SUBJECT TO THE EXPRESS APPROVAL OF BRASSTECH. UNAUTHORIZED USE IS STRICTLY PROHIBITED. ALL RIGHTS RESERVED.

TESTING	-	-	-
ASSEMBLY	-	-	-
PLATING	-	-	-
POLISHING	-	NEXT ASSY	USED ON
MACHINING	-	APPLICATION	
TOOLING FIXTURE #	REMOVE ALL BURRS AND SHARP EDGES		

UNITS ARE: INCHES [MM]
 TOLERANCES ARE:
 FRACTIONS DECIMALS ANGLES
 $\pm 1/16"$.X $\pm .1$ (2,5) $\pm 1^\circ$
 $.XX \pm .06$ (1,5)

(X.XXX) DENOTES CRITICAL DIMS.
 ALL THREADS ARE CRITICAL

DRAWN	MANJUNATH	11/29/19
CHECKED	C.G.	11/29/19
APPROVED	C.G.	11/29/19

BRASSTECH 2001 CARNEGIE AVE.
 INCORPORATED SANTA ANA, CA 92705
 (949) 417-5207

H & C WATER DISP, LEVER
 TRAD

DWG NO.	107	REV	T
SCALE	.280	REF.	-
SHEET	1	OF	3

4

3

2

1

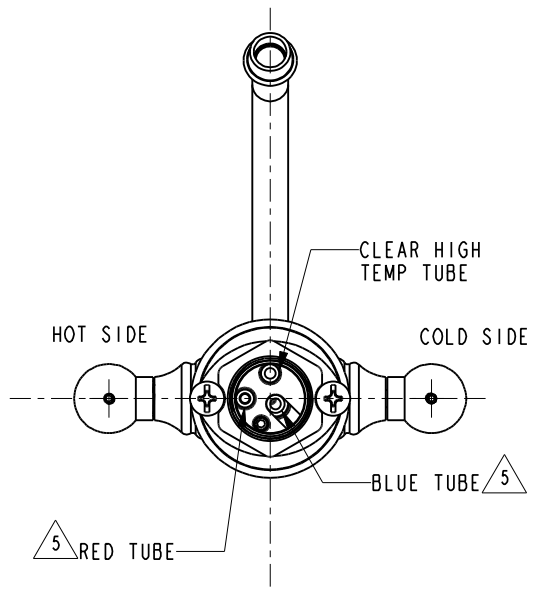
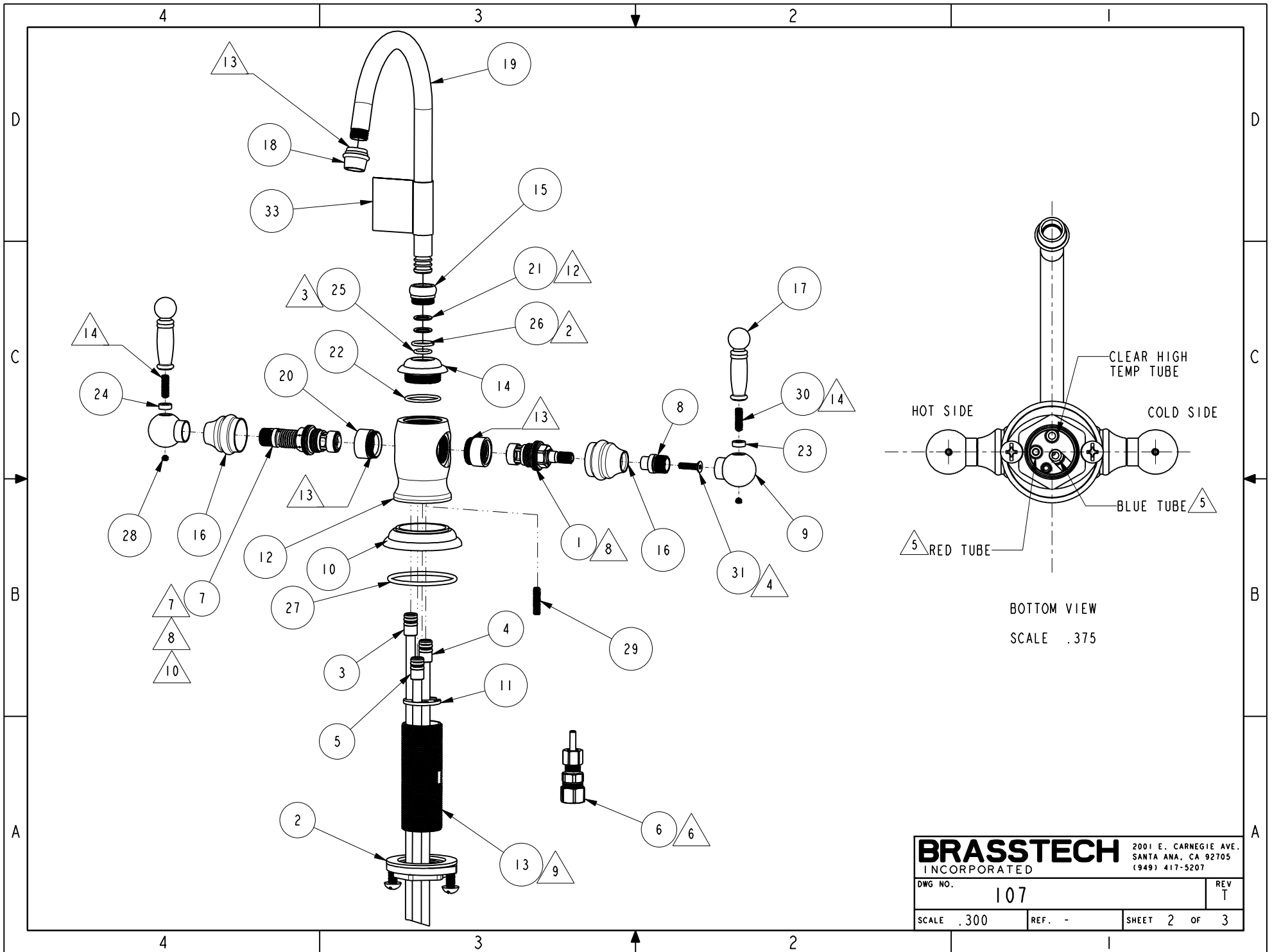

BOTTOM VIEW
SCALE .375

BRASSTECH		2001 E. CARNEGIE AVE. SANTA ANA, CA 92705 (949) 417-5207	
DWG NO.	107	REV	T
SCALE .300	REF. -	SHEET 2	OF 3

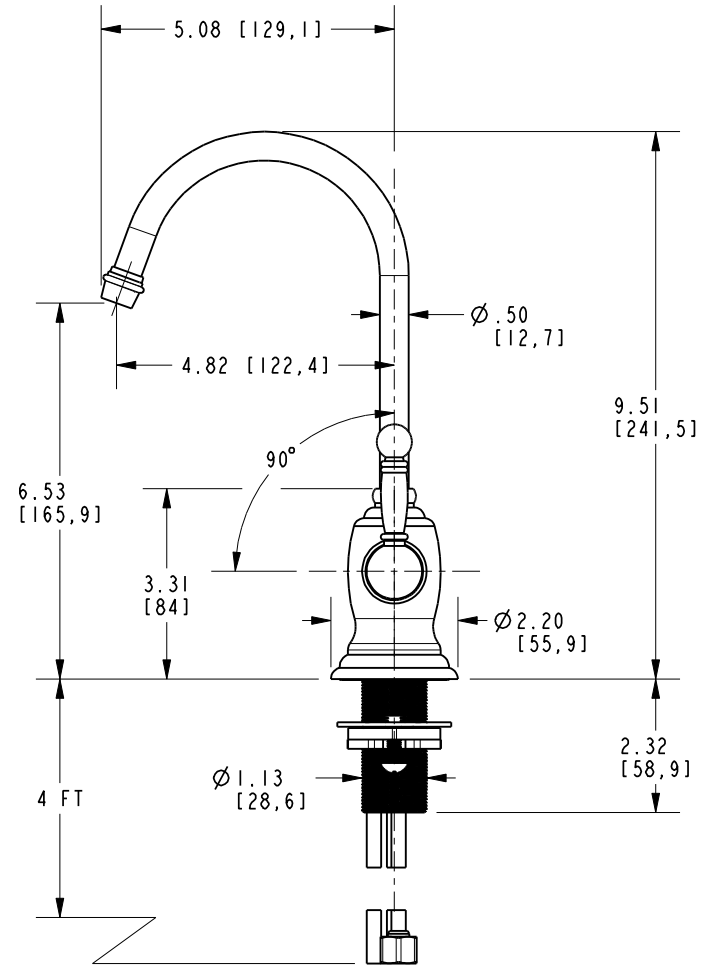
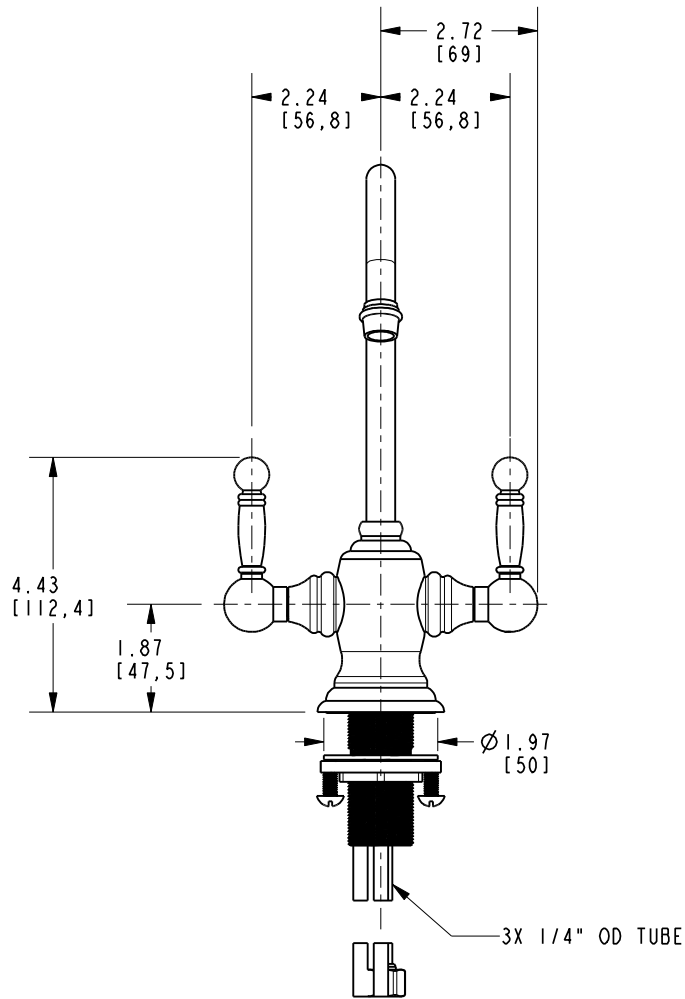

BRASSTECH		2001 E. CARNEGIE AVE. SANTA ANA, CA 92705 (949) 417-5207	
DWG NO.	107	REV	T
SCALE	.300	REF.	-
		SHEET	3 OF 3