

NOTES:

(N1) 1. FIT / FORM / FUNCTION SHALL FOLLOW PS-E.008.

(N2)  2 APPLY LOCTITE 680.

BILL OF MATERIAL (CURRENT LEVEL)

ITEM	PT/ASSY	DESCRIPTION	TYPE	QTY.
1	6XXA	MOUNTING BRACKET	PART	2
2	1-206	HARDWARE PACK	ASSEMBLY	2
3	600A	HEX CONE	PART	2
4	40811	TOWEL BAR POST - RIGHT	PART	1
5	40812	TOWEL BAR POST - LEFT	PART	1
6	92308	SCRW, M5 X 5 SKT HD CUP PT W/ SELF LOC SS	PART	2
7	40813	ADAPTER	PART	2
8	92299	SCRW, M4 X 0.7 X 8 SKT CAP ALOY STL	PART	2
9	10888	HEX KEY, 2.5MM ALLOY STEEL	PART	1
10	1108TN	TOILET TISSUE ROLLER	ASSEMBLY	1

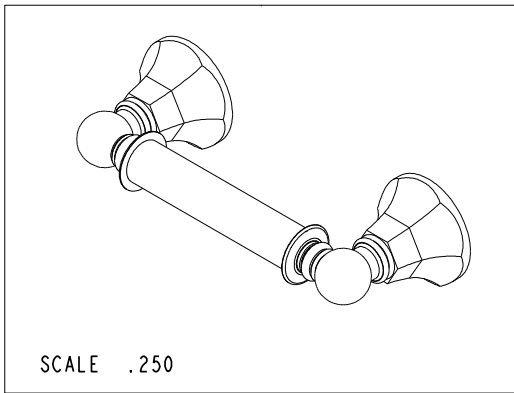
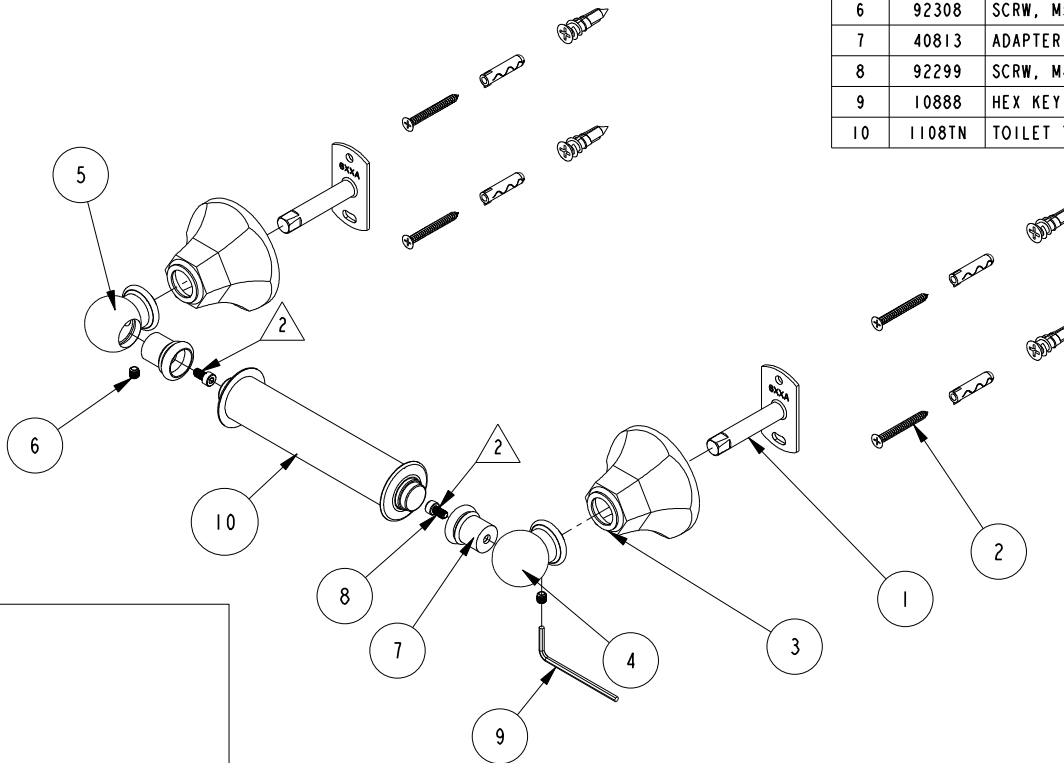

TESTING	-	-	-
ASSEMBLY	-	-	-
PLATING	-	-	-
POLISHING	-	NEXT ASSY	USED ON
MACHINING	-	APPLICATION	
TOOLING FIXTURE #	REMOVE ALL BURRS AND SHARP EDGES		

UNITS ARE: INCHES [MM]		
TOLERANCES ARE:		
FRACTIONS	DECIMALS	ANGLES
±1/16"	.X ±.1 [2.5]	±1°
	.XX ±.06 [1.5]	
(X.XXX) DENOTES CRITICAL DIMS.		
ALL THREADS ARE CRITICAL		
DRAWN	R.S.	08/15/19
CHECKED	J.M.	08/15/19
APPROVED	J.M.	08/15/19

BRASSTECH 2001 CARNEGIE AVE.
INCORPORATED SANTA ANA, CA 92705
(949) 417-5207

DOUBLE POST TT HOLDER

-	A	EN-4121	03/02/20	J.M.
-	-	EN-3913	08/15/19	J.M.
ZONE	REV	DESCRIPTION	DATE	APPROVED

COPYRIGHT 2005 BRASSTECH, INC. THESE DRAWINGS AND THE DESIGNS DEPICTED HEREIN ARE THE PROPRIETARY PROPERTY OF BRASSTECH. ANY USE OR REPRODUCTION IS SUBJECT TO THE EXPRESS APPROVAL OF BRASSTECH. UNAUTHORIZED USE IS STRICTLY PROHIBITED. ALL RIGHTS RESERVED.

DWG NO.	1200-1500	REV	A
SCALE	.250	REF.	-
SHEET	1	OF	2

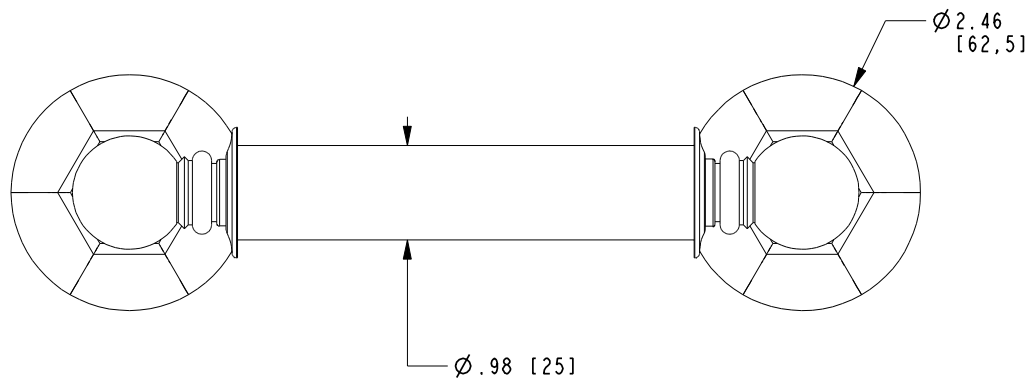
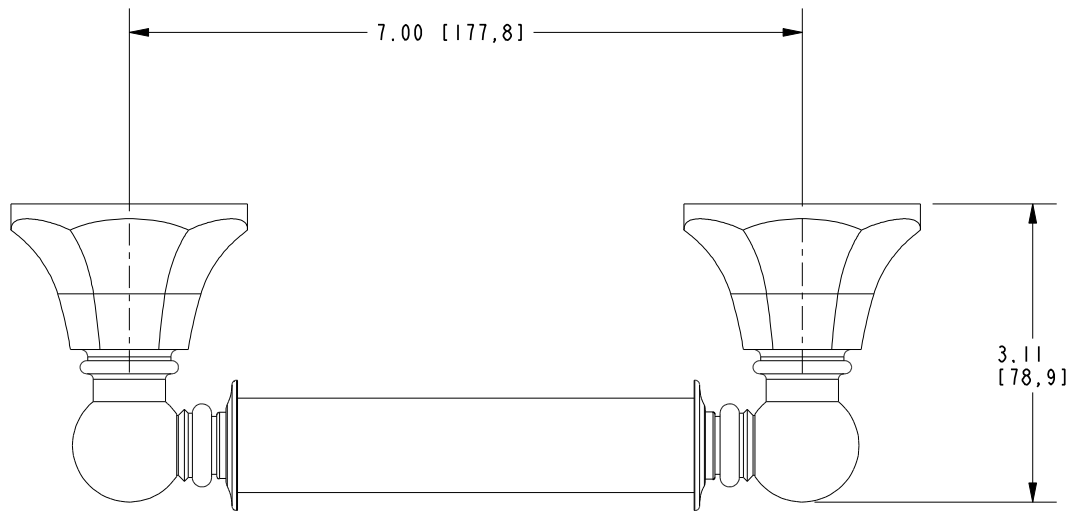

BRASSTECH		2001 E. CARNEGIE AVE. SANTA ANA, CA 92705 (949) 417-5207
DWG NO.	1200-1500	REV A
SCALE .325	REF. -	SHEET 2 OF 2