

NOTES:

1. TO INSPECT ASSEMBLY, FOLLOW FIRST ARTICLE AND IN PROCESS INSPECTION SHEET.

- 2 APPLY LOCTITE 242.
- 3 APPLY LOCTITE 680
- 4 TORQUE 15-20 IN-LB
- 5 WRAP AROUND SHANK

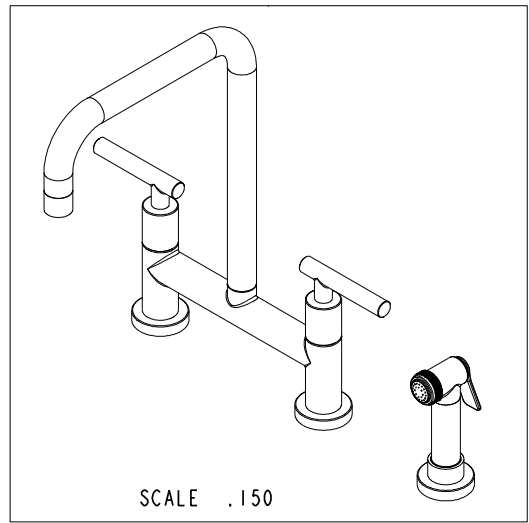
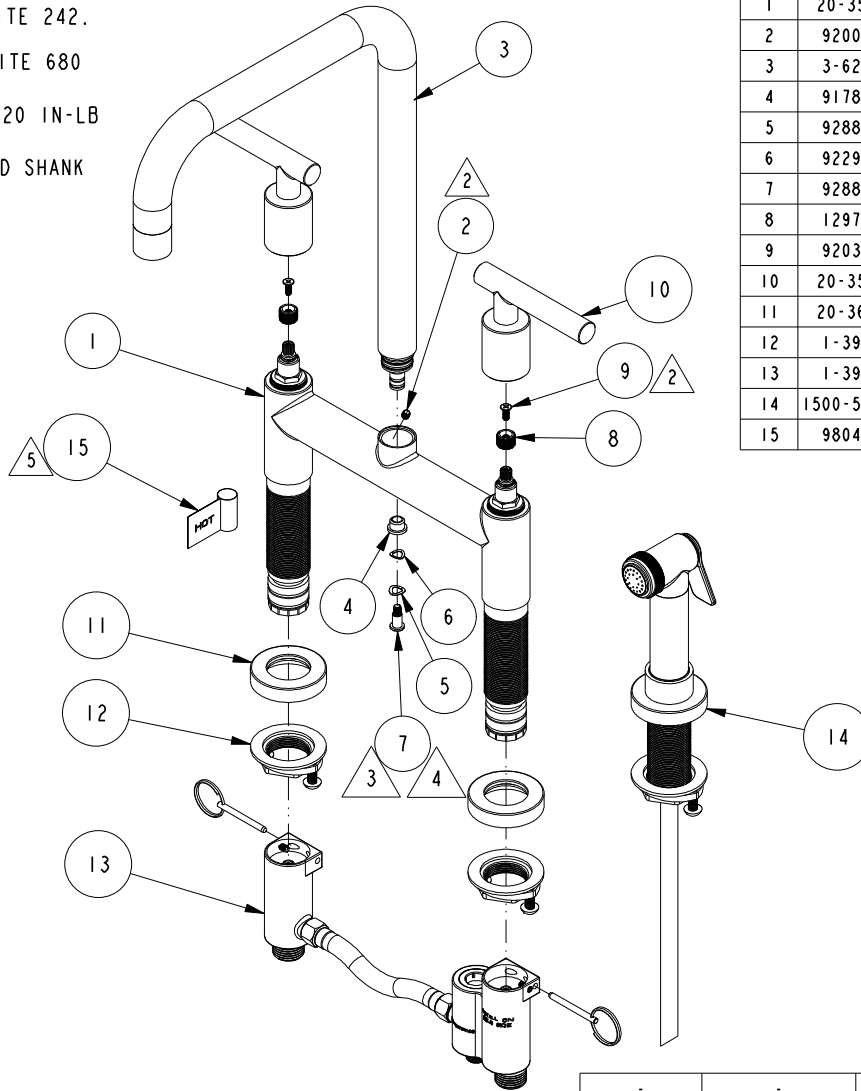

BILL OF MATERIAL (CURRENT LEVEL)

ITEM	PT/ASSY	DESCRIPTION	TYPE	QTY.
1	20-353	KITCHEN BRIDGE BODY ASM, SIDE SPRAY	ASSEMBLY	1
2	92004	SCRW, 10-32 X 3/16 SKT HD FLT PT SS	PART	1
3	3-625	SPOUT ASSEMBLY	ASSEMBLY	1
4	91783	FLANGED SLEEVE BEARING	PART	1
5	92883	WSHR, .27 ID X .42 OD X .008 THK, WAVE, SPRING STEEL	PART	1
6	92293	WSHR, .24 ID X .39 OD X .01 THK, WAVE, SPRING STEEL	PART	1
7	92884	SCRW, 10-32 X 3/8 SKT CAP LOW HD SS	PART	1
8	12975	ADAPTER	PART	2
9	92035	SCRW, M4 X .7 X 10 PHL FLT HD SS	PART	2
10	20-352	LEVER HANDLE ASM	ASSEMBLY	2
11	20-368	ESCUTCHEON ASM	ASSEMBLY	2
12	1-393	1-1/8 18 UNEF MOUNTING KIT	ASSEMBLY	2
13	1-396	DIVERTER ASM, BRIDGE FAUCET	ASSEMBLY	1
14	1500-5703	KITCHEN SPRAY HEAD	ASSEMBLY	1
15	98044	LABEL - HOT	PART	1

ZONE	REV	DESCRIPTION	DATE	APPROVED
-	C	EN-4300f	02/24/21	R. S.
-	B	EN-3866	05/17/19	J. M.
-	A	EN-3818	02/25/19	J. M.
-	-	EN-3364	09/25/18	J. M.

COPYRIGHT 2005 BRASSTECH, INC. THESE DRAWINGS AND THE DESIGNS DEPICTED HEREIN ARE THE PROPRIETARY PROPERTY OF BRASSTECH. ANY USE OR REPRODUCTION IS SUBJECT TO THE EXPRESS APPROVAL OF BRASSTECH. UNAUTHORIZED USE IS STRICTLY PROHIBITED. ALL RIGHTS RESERVED.

TESTING	-	-	-
ASSEMBLY	-	-	-
PLATING	-	-	-
POLISHING	-	NEXT ASSY	USED ON
MACHINING	-	APPLICATION	
TOOLING FIXTURE #	REMOVE ALL BURRS AND SHARP EDGES		

UNITS ARE: INCHES [MM]			
TOLERANCES ARE:			
FRACTIONS	DECIMALS	ANGLES	
±1/16"	.X ±.1 [2.5]	±1°	
	.XX ±.06 [1.5]		
(X.XXX) DENOTES CRITICAL DIMS. ALL THREADS ARE CRITICAL			
DRAWN	JIMSON	09/25/18	
CHECKED	J.M.	09/25/18	
APPROVED	J.M.	09/25/18	

BRASSTECH 2001 CARNEGIE AVE. SANTA ANA, CA 92705 (949) 417-5207
 INCORPORATED

KITCHEN BRIDGE FAUCET W/ SPRAY

DWG NO. **1400-5413** REV **C**

SCALE .200 REF. - SHEET 1 OF 2

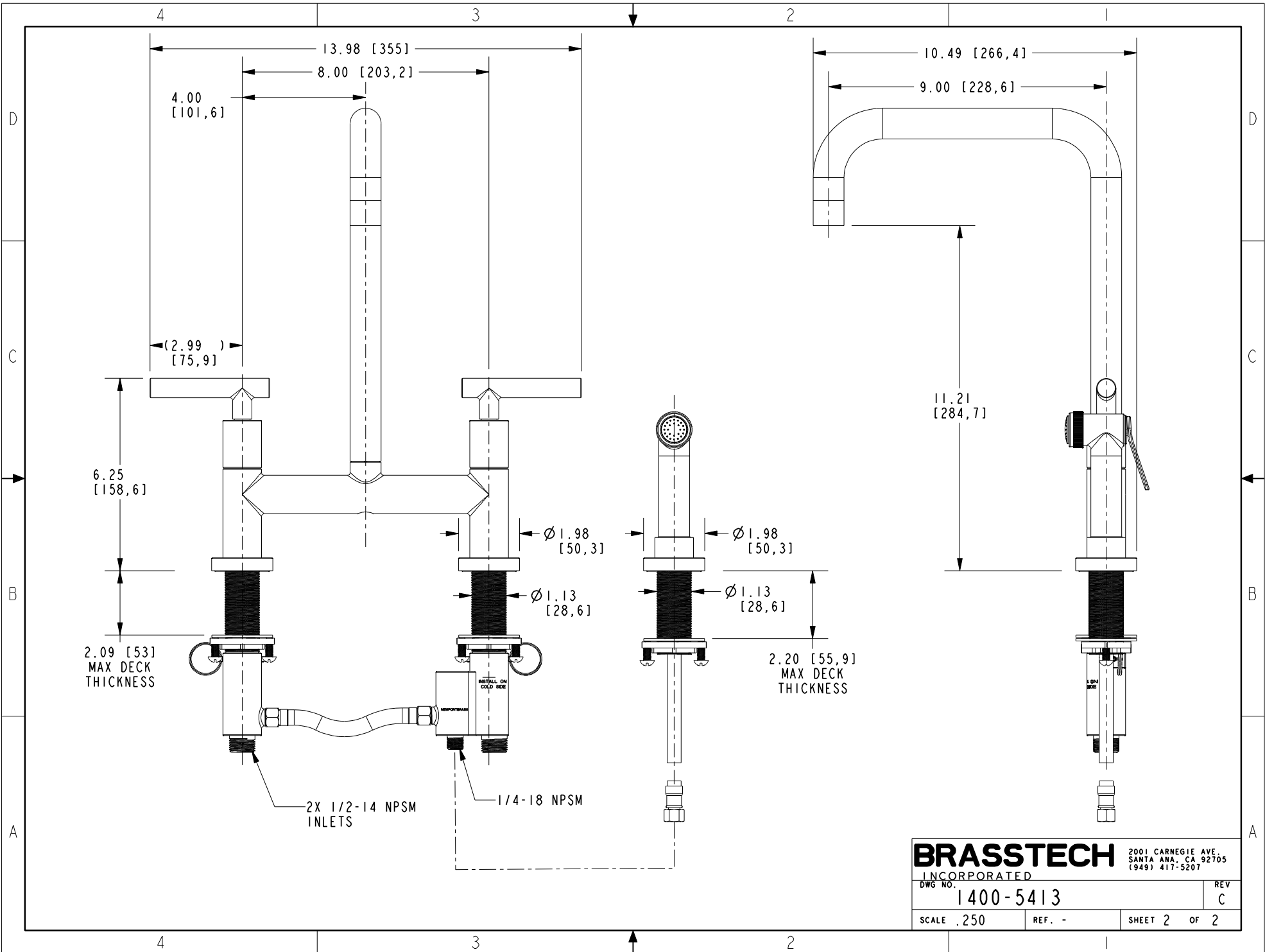

BRASSTECH 2001 CARNEGIE AVE.
 INCORPORATED SANTA ANA, CA 92705
 (949) 417-5207

DWG NO.	1400-5413	REV	C
SCALE	.250	REF.	-
SHEET 2		OF 2	