

EN Installation / Warranty

FR Instructions de montage / Garantie

ES Instrucciones de montaje / Garantía

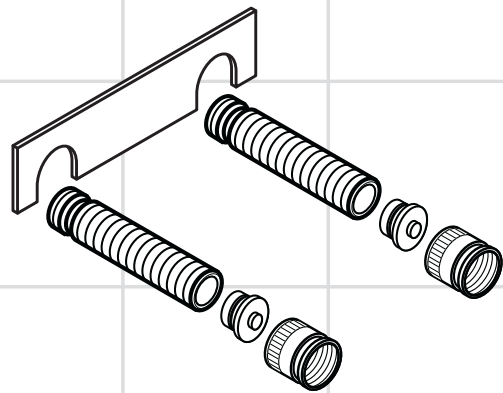

Rough set for Showerpipe

16181181

Technical Information

Water pressure	
Recommended	15 - 75 PSI (0.1 - 0.5 MPa)
Maximum	145 PSI (1 MPa)
Hot water temp.	
Recommended	120°-140° F (48° - 60° C)*
Maximum	158° F (70° C)*

* Please know and follow all applicable local plumbing codes when setting the temperature on the water heater.

Installation Considerations

- For best results, Hansgrohe recommends that this unit be installed by a licensed, professional plumber.
- Please read over these instructions thoroughly before beginning installation. Make sure that you have all tools and supplies needed to complete the installation.
- This rough set is for use with several models of Hansgrohe showerpipes and wall-mounted mixing valves.

⚠ Read the instructions included with your showerpipe regarding installation recommendations, minimum ceiling height requirements, etc.

⚠ Install the hot supply on the left and the cold supply on the right. If the showerpipe is not supplied correctly, the mixing valve cannot function correctly.

- To prevent scald injury, the maximum output temperature of the shower valve must be no higher than 120°F (49°C) . In Massachusetts, the maximum output temperature can be no higher than 112°F (44°C) .
- Keep this booklet and the receipt (or other proof of date and place of purchase) for this product in a safe place. The receipt is required should it be necessary to request warranty parts.

Données techniques

Pression d'eau	
recommandée	15 - 75 PSI (0.1 - 0.5 MPa)
maximum	145 PSI (1 MPa)
Température d'eau chaude	
recommandée	120°-140° F (48° - 60° C)*
maximum	158° F (70° C)*

* Vous devez connaître et respecter tous les codes de plomberie locaux applicables pour le réglage de la température du chauffe-eau.

À prendre en considération pour l'installation

- Pour de meilleurs résultats, Hansgrohe recommande que ce produit soit installé par un plombier professionnel licencié.
- Veuillez lire attentivement ces instructions avant de procéder à l'installation. Assurez-vous de disposer de tous les outils et du matériel nécessaires pour l'installation.
- Cet ensemble de pièce intérieure est conçu pour l'utilisation avec plusieurs modèles de tuyaux de douche et robinets mélangeurs muraux d'Hansgrohe.

⚠ Lisez les instructions fournies avec votre tuyau de douche ou robinet mélangeur concernant les recommandations d'installation, les exigences de hauteur de plafond minimale, etc.

⚠ Installez la conduite d'eau chaude à gauche et la conduite d'eau froide à droite. Si l'alimentation n'est pas raccordée adéquatement, le mélangeur ne fonctionnera pas correctement.

- Pour empêcher des blessures par ébouillamment, la température de sortie maximale du robinet de douche ne doit pas excéder 120°F (49°C) . Au Massachusetts, la température de sortie maximale du robinet de douche ne doit pas excéder 112°F (44°C) .
- Conservez ce livret et le reçu (ou une autre preuve sur laquelle figurent la date et l'endroit de l'achat) pour ce produit dans un endroit sûr. Le reçu est requis si vous commandez des pièces sous garantie.

Datos técnicos

Presión en servicio
 recomendada 15 - 75 PSI (0.1 - 0.5 MPa)
 max. 145 PSI (1 MPa)
 Temperatura del agua caliente
 recomendada 120°-140° F (48° - 60° C)*
 max. 158° F (70° C)*

* Debe conocer y cumplir todos los códigos locales aplicables para ajustar la temperatura del calentador de agua.

Consideraciones para la instalación

- Para obtener mejores resultados, la instalación debe estar a cargo de un plomero profesional matriculado.
- Antes de comenzar la instalación, lea estas instrucciones detenidamente. Asegúrese de tener las herramientas y los insumos necesarios para completar la instalación.
- Este juego de piezas interiores se puede usar con varios modelos de tubos de ducha y válvulas mezcladoras montadas en la pared de Hansgrohe.

⚠ Lea las instrucciones incluidas con su tubo de ducha o válvula mezcladora respecto de las recomendaciones para la instalación, los requisitos de altura mínima del techo, etc.

⚠ El suministro de agua caliente debe instalarse en la izquierda y el suministro de agua fría a la derecha. Si los suministros de la unidad no están instalados correctamente, el mezclador no funcionará de forma adecuada.

- Para evitar escaldaduras, la máxima temperatura de salida de la válvula de la ducha no debe exceder los 120° F (49° C) . En Massachusetts, la máxima temperatura de salida de la válvula de la ducha no debe exceder los 112° F (44° C)

- Mantenga este folleto y el recibo (u otro comprobante del lugar y fecha de compra) de este producto en lugar seguro. El recibo se requiere en caso de ser necesario solicitar piezas bajo garantía.

Tools Required / Outils Utiles / Herramientas Útiles

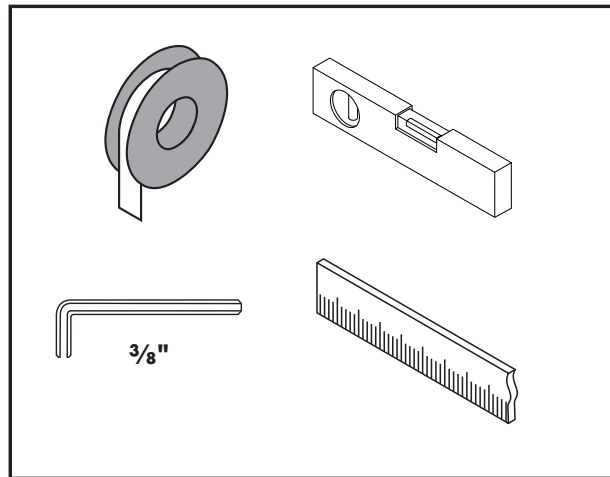

Rough set for Showerpipe 16181181

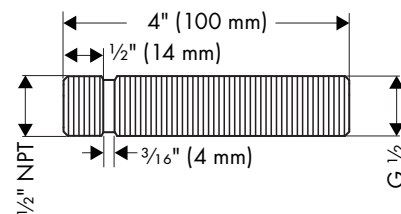
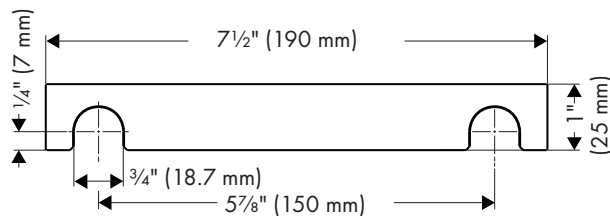

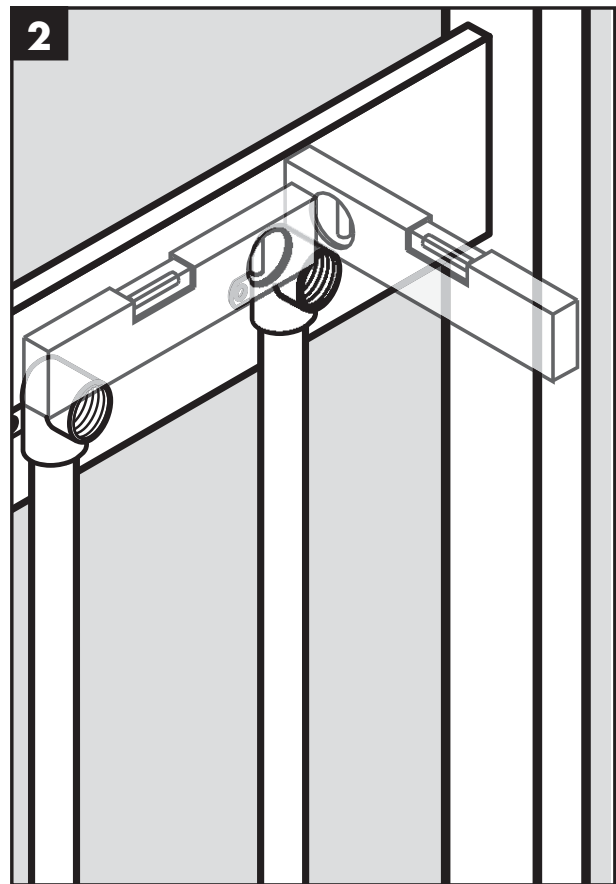
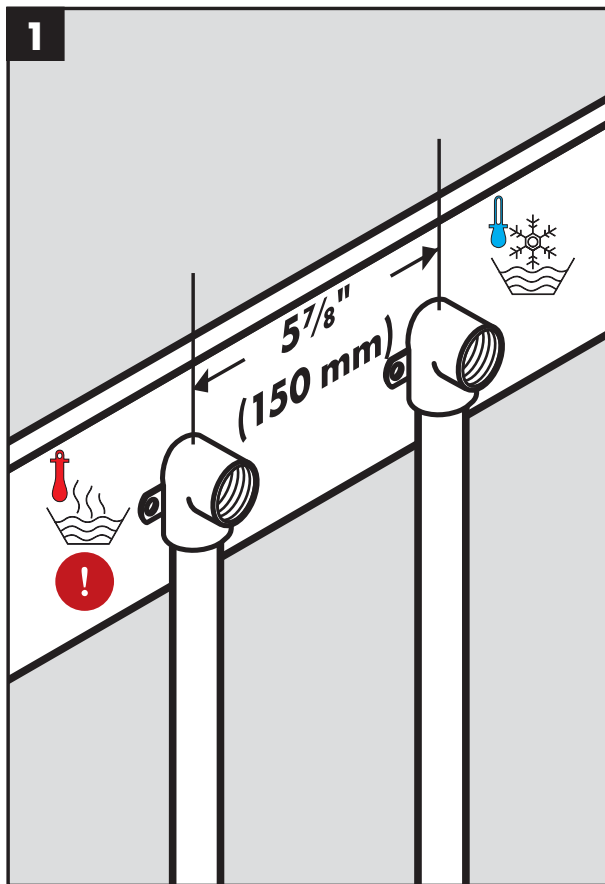

English

This rough set requires two properly anchored 1/2" NPT drop-eared ells for the hot and cold supplies for the showerpipe.

Install the hot supply on the left and the cold supply on the right.

The drop-eared ells must be:

- level
- parallel to each other
- perpendicular to the finished wall.

If these conditions are not met, the showerpipe cannot be installed.

Français

Cette pièce intérieure nécessite deux coudes appliques filetés NPT de 1/2 po correctement fixés pour les conduites d'alimentation d'eau chaude et d'eau froide du tuyau de douche.

Installez la conduite d'eau chaude à gauche et la conduite d'eau froide à droite.

Les coudes appliques doivent être:

- au niveau
- installés de manière parallèle
- perpendiculaires au mur fini.

Si ces conditions ne sont pas remplies, le tuyau de douche ne pourra pas être installé.

Español

Este juego de piezas interiores precisa dos codos NPT de 1/2" correctamente anclados para los suministros de agua fría y agua caliente del tubo de ducha.

El suministro de agua caliente debe instalarse en la izquierda y el suministro de agua fría a la derecha.

Los codos deben estar :

- nivelados
- paralelos entre sí
- perpendiculares a la pared terminada.

Si no se cumplen estas condiciones, no podrá instalarse el tubo de ducha.

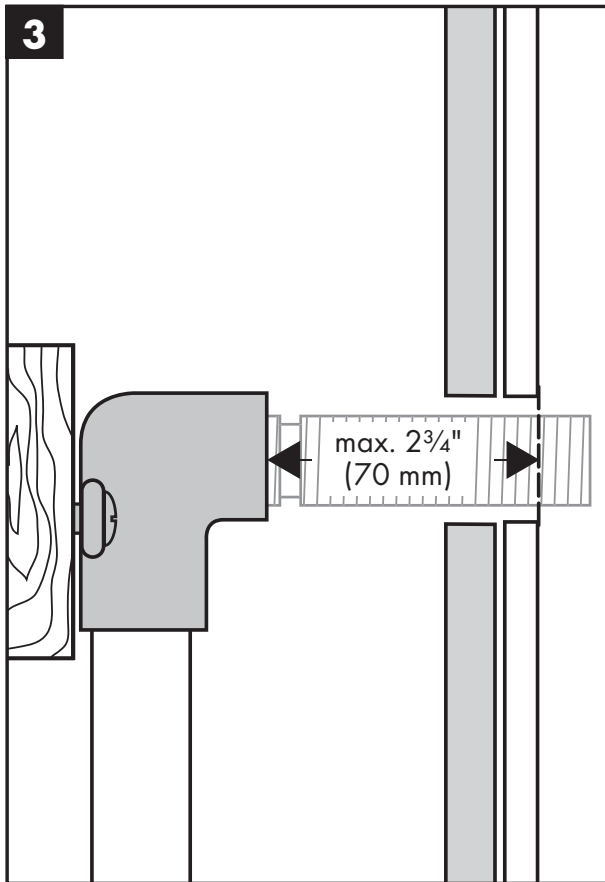

English

The ells must be installed a maximum of 2³/₄" (70 mm) behind the surface of the finished wall.

Remove the nuts and the plugs from the nipples.

Wrap the 1/2" NPT threads with plumbers' tape.

Français

Les coudes appliques doivent être installés à un maximum de 2³/₄ po (70 mm) derrière la surface du mur fini.

Retirez les écrous et les bouchons des raccords filetés.

Enveloppez les filets NPT de 1/2 po avec du ruban de plombier.

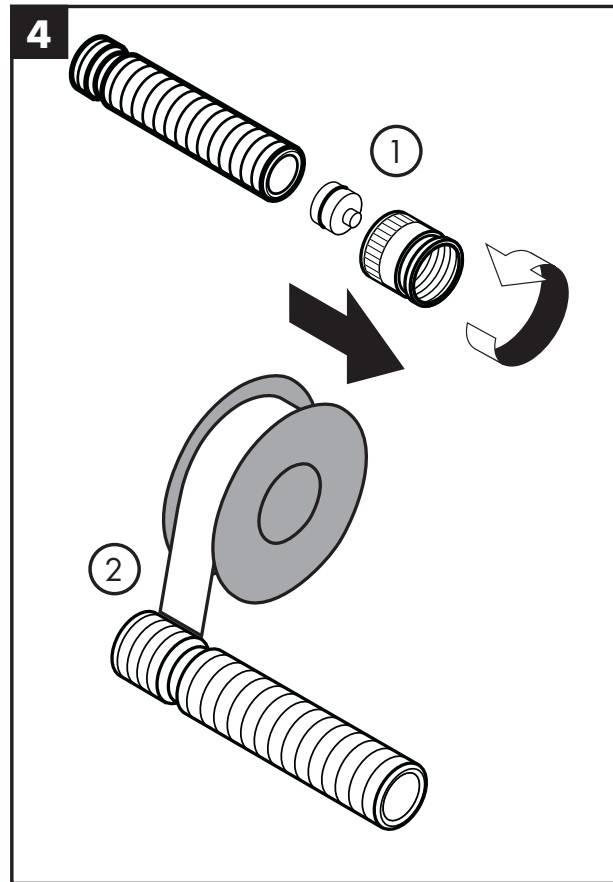

Español

Los codos deben estar instalados a un máximo de 2³/₄" (70 mm) por detrás de la superficie de la pared terminada.

Retire las tuercas y los tapones de los nipples.

Envuelva las roscas NPT de 1/2" con cinta de plomero.

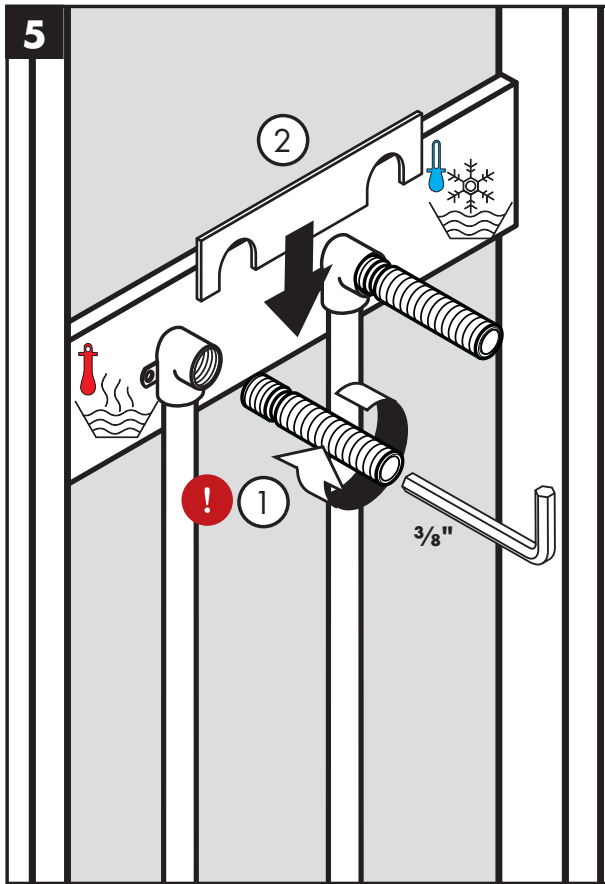

English

Install the nipples in the ells.

⚠ Do not over-tighten the nipples or damage may result.

Install the spacing jig.

Make sure that the nipples are level in all planes.

The nipples must be parallel to each other and perpendicular to the finished wall.

Français

Installez les raccords filetés dans les coudes appliques.

⚠ Ne serrez pas excessivement les raccords filetés, car vous pourriez les endommager.

Installez le gabarit d'espacement.

Assurez-vous que les raccords filetés sont au niveau sur tous les plans.

Les nipples doivent être au niveau, installés de manière parallèle, et perpendiculaires au mur fini.

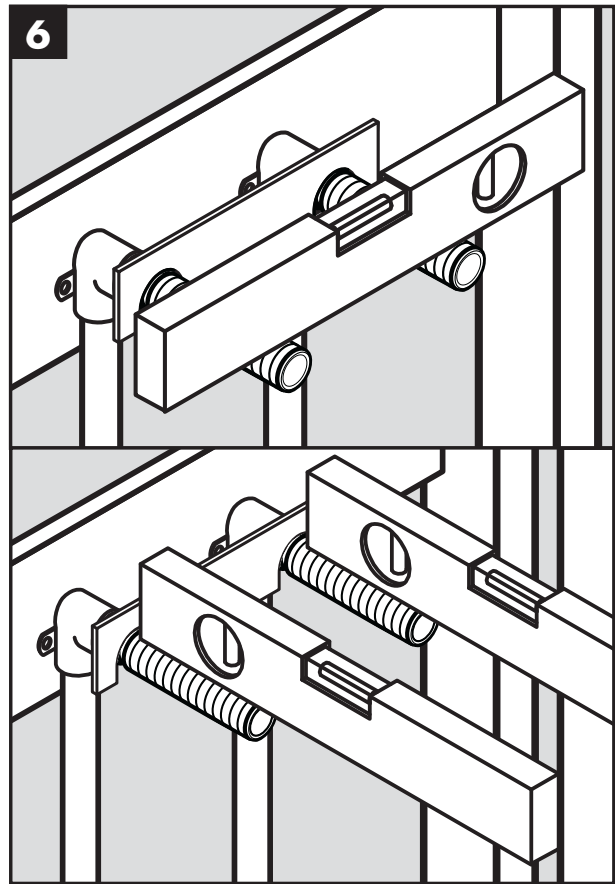

Español

Instale los nipples en los codos.

⚠ No apriete los nipples en exceso, ya que podría dañarlos.

Instale la plantilla espaciadora.

Asegúrese de que los nipples estén nivelados en todos los planos.

Los nipples deben estar nivelados, paralelos entre sí, y perpendiculares a la pared terminada.

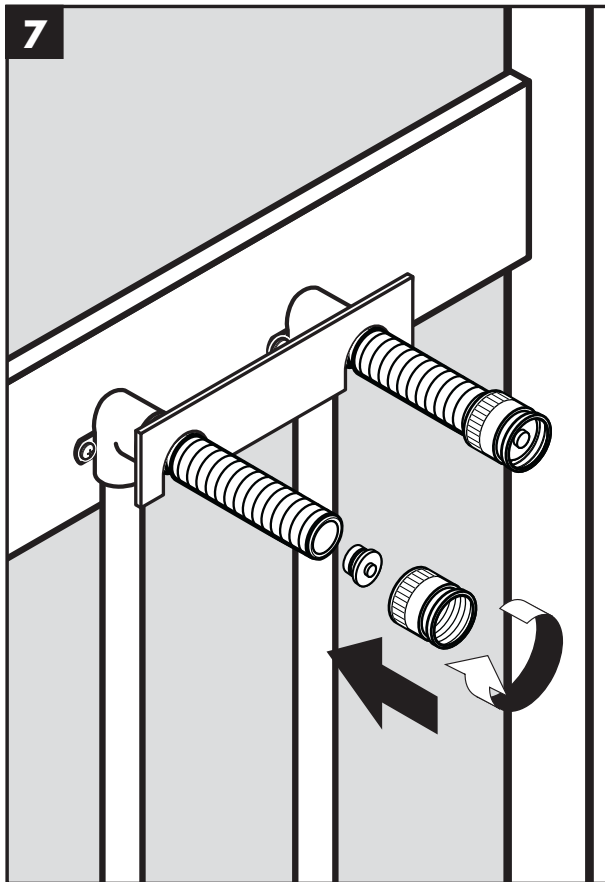

English

Install the plugs and nuts.
 Pressurize the system and test for leaks.

Move the spacing jig to the slots on the nuts.

Français

Réinstallez les bouchons et écrous.
 Mettez le système sous pression et faites un essai pour vérifier s'il y a des fuites.

Placez le gabarit d'espacement sur les ouvertures des écrous.

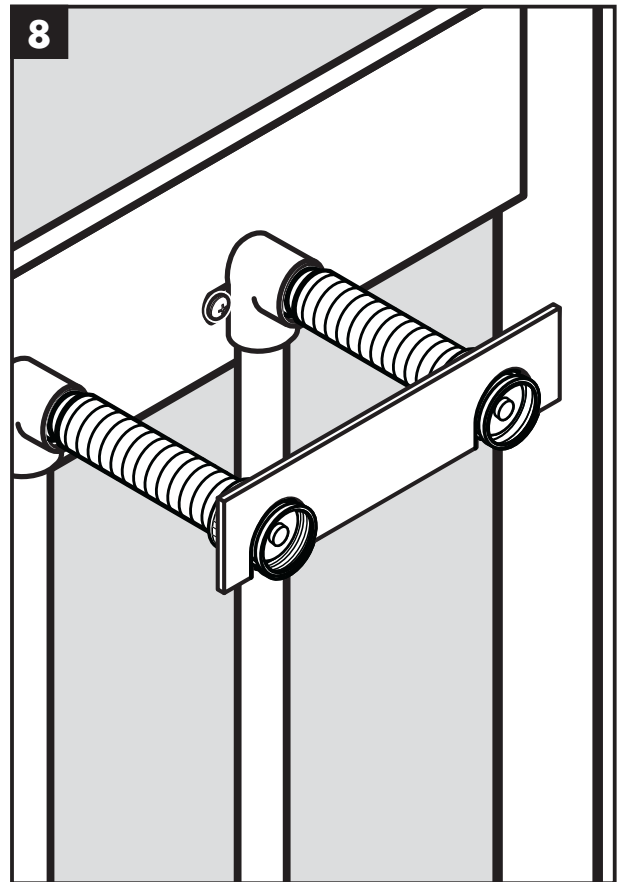

Español

Reemplace los tapones y las tuercas.
 Presurice el sistema y verifique que no haya pérdidas.

Mueva la plantilla espaciadora a las ranuras de las tuercas.

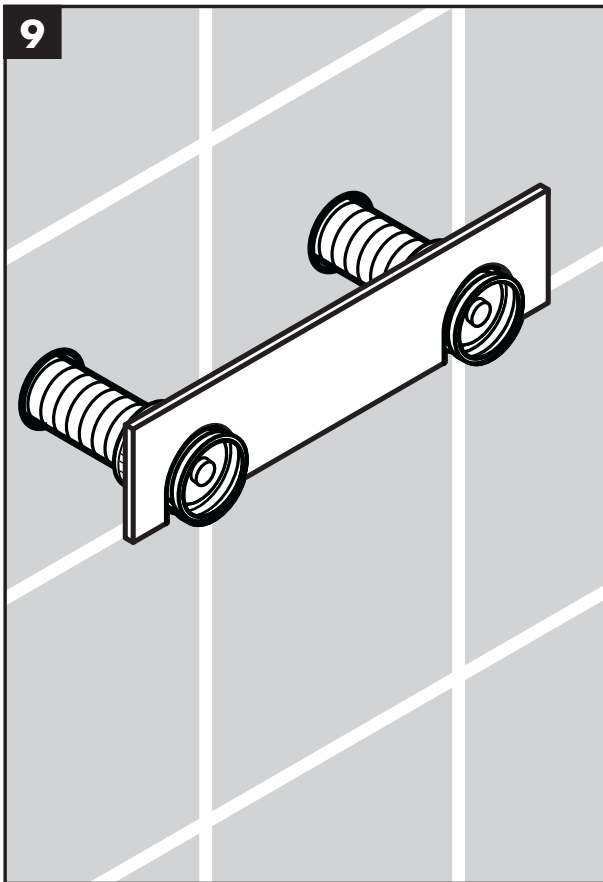

English

Install the finished wall.

Français

Installez le mur fini.

Español

Instale la pared terminada.



Limited Consumer Warranty

This warranty is limited to products manufactured by Hansgrohe, Inc. ("Hansgrohe") that are purchased by a consumer in the United States or Canada after March 1, 1996, and installed in either the United States or in Canada.

WHO IS COVERED BY THE WARRANTY

This limited warranty extends to the original purchaser only. This warranty is non-transferable. Hansgrohe neither assumes nor authorizes any person to create for it any other obligation or liability in connection with this product.

LENGTH OF WARRANTY

If you are a consumer who purchased the product for use primarily for personal, family or household purposes, this limited warranty starts on the date of purchase and extends for as long as you own the product and the home in which the product is originally installed. If you purchased the product for use primarily for any other purpose, including, without limitation, a commercial purpose, this limited warranty starts on the date of purchase and extends (i) for 1 year, with respect to Hansgrohe and Commercial products, and (ii) for 5 years, with respect to Axor products. The Rubbed Bronze finish is subject to a 3-year limited warranty starting on the date of purchase.

WHAT IS COVERED BY THE WARRANTY

This limited warranty covers only your Hansgrohe manufactured product. Hansgrohe warrants this product against defects in material or workmanship as follows:

Hansgrohe will replace at no charge for parts only or, at its option, replace any product or part of the product that proves defective because of improper workmanship and/or material, under normal installation, use, service and maintenance. If Hansgrohe is unable to provide a replacement and repair is not practical or cannot be made in timely fashion, Hansgrohe may elect to refund the purchase price in exchange for the return of the product. REPAIR OR REPLACEMENT (OR, IN LIMITED CIRCUMSTANCES, REFUND OF THE PURCHASE PRICE) AS PROVIDED UNDER THIS LIMITED WARRANTY IS THE EXCLUSIVE REMEDY OF THE PURCHASER.

WHAT IS NOT COVERED BY THE WARRANTY

- A. Conditions, malfunctions or damage not resulting from defects in material or workmanship.
- B. Conditions, malfunctions or damage resulting from (1) normal wear and tear, improper installation, improper maintenance, misuse, abuse, negligence, accident or alteration; (2) the use of abrasive or caustic cleaning agents or "no-rinse" cleaning products, or the use of the product in any manner contrary to the product instructions; or (3)

conditions in the home such as excessive water pressure or corrosion.

- C. Labor and other expenses for disconnection, deinstallation, or return of the product for warranty service (including but not limited to proper packaging and shipping costs), or for installation or reinstallation of the product.
- D. Accessories, connected materials and products, or related products not manufactured by Hansgrohe.
- E. Any Hansgrohe or Axor product sold for display purposes.

HANSGROHE SHALL NOT BE LIABLE TO PURCHASER OR ANY OTHER PERSON FOR ANY INCIDENTAL, SPECIAL OR CONSEQUENTIAL DAMAGES, ARISING OUT OF BREACH OF THIS LIMITED WARRANTY.

Some provinces and some states do not allow the exclusion or limitation of incidental or consequential damages, so the above limitation or exclusion may not apply to you.

TO OBTAIN WARRANTY PARTS OR INFORMATION

Contact your Hansgrohe retailer, or contact Technical Service at:

Hansgrohe, Inc.
1492 Bluegrass Lakes Parkway
Alpharetta, GA 30004
Toll-free 800-334-0455

In requesting warranty service, you will need to provide:

1. The sales receipt or other evidence of the date and place of purchase.
2. A description of the problem.
3. Delivery of the product or the defective part, postage prepaid and carefully packed and insured, to:

Hansgrohe, Inc.
1492 Bluegrass Lakes Parkway
Alpharetta, GA 30004
Toll-free 800-334-0455

When warranty service is completed, any repaired or replacement product or part will be returned to you postage prepaid. REVISED MAY 1, 2016.

PRODUCT INSTRUCTIONS AND QUESTIONS

Upon purchase or prior to installation, please carefully inspect your Hansgrohe product for any damage or visible defect. Prior to installing, always carefully study the enclosed instructions on the proper installation and the care and maintenance of this product. If you have questions at any time about the use, installation or performance of your Hansgrohe product, or this warranty, please write us or call us toll-free at 800-334-0455.

hansgrohe

Hansgrohe, Inc. • 1490 Bluegrass Lakes Parkway • Alpharetta, GA 30004
Tel. 800-334-0455 • Fax 770-889-1783
www.hansgrohe-usa.com