

AXOR[®]

hansgrohe

- EN** Installation / User Instructions / Warranty
- FR** Instructions de montage / Mode d'emploi / Garantie
- ES** Instrucciones de montaje / Manejo / Garantía

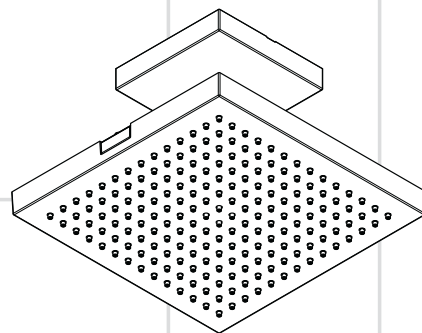

Starck
26414xx1
10926xx1

Technical Information

Flow rate

2.5 GPM

*Please know and follow all applicable local plumbing codes when setting the temperature on the water heater.

Installation Considerations

- For best results, Hansgrohe recommends that this unit be installed by a licensed, professional plumber.
- Please read over these instructions thoroughly before beginning installation. Make sure that you have all tools and supplies needed to complete the installation.
- **Showerhead 10926xx1 requires ceiling shower arm 26414001 (sold separately).**
- To prevent scald injury, the maximum output temperature of the shower valve must be no higher than 120° F. In Massachusetts, the maximum output temperature can be no higher than 112° F.
- Keep this booklet and the receipt (or other proof of date and place of purchase) for this product in a safe place. The receipt is required should it be necessary to request warranty parts.

Données techniques

Capacité nominale 2.5 GPM

* Vous devez connaître et respecter tous les codes de plomberie locaux applicables pour le réglage de la température du chauffe-eau.

À prendre en considération pour l'installation

- Pour de meilleurs résultats, Hansgrohe recommande que ce produit soit installé par un plombier professionnel licencié.
- Veuillez lire attentivement ces instructions avant de procéder à l'installation. Assurez-vous de disposer de tous les outils et du matériel nécessaires pour l'installation.
- **La pomme de douche 10926xx1 nécessite l'utilisation du bras de douche de plafond 26414xx1 (vendu séparément).**
- Pour empêcher des blessures par ébullition, la température de sortie maximale du robinet de douche ne doit pas excéder 120 °F. Au Massachusetts, la température de sortie maximale du robinet de douche ne doit pas excéder 112 °F.
- Conservez ce livret et le reçu (ou une autre preuve sur laquelle figurent la date et l'endroit de l'achat) pour ce produit dans un endroit sûr. Le reçu est requis si vous commandez des pièces sous garantie.

Datos técnicos

Caudal máximo 2.5 GPM

* Debe conocer y cumplir todos los códigos locales aplicables para ajustar la temperatura del calentador de agua.

Consideraciones para la instalación

- Para obtener mejores resultados, la instalación debe estar a cargo de un plomero profesional matriculado.
- Antes de comenzar la instalación, lea estas instrucciones detenidamente. Asegúrese de tener las herramientas y los insumos necesarios para completar la instalación.
- **El cabezal de ducha 10926xx1 requiere un brazo de ducha para cielo raso 26414xx1 (se vende por separado).**
- Para evitar escaldaduras, la máxima temperatura de salida de la válvula de la ducha no debe exceder los 120 °F. En Massachusetts, la máxima temperatura de salida de la válvula de la ducha no debe exceder los 112 °F.
- Mantenga este folleto y el recibo (u otro comprobante del lugar y fecha de compra) de este producto en lugar seguro. El recibo se requiere en caso de ser necesario solicitar piezas bajo garantía.

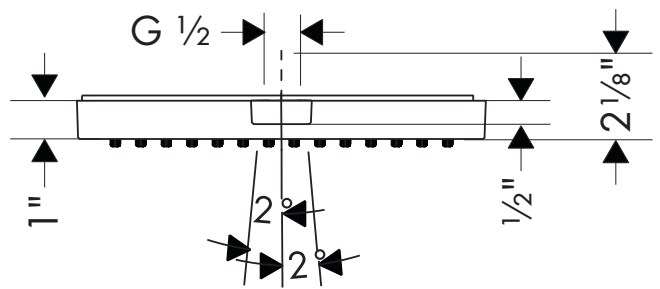
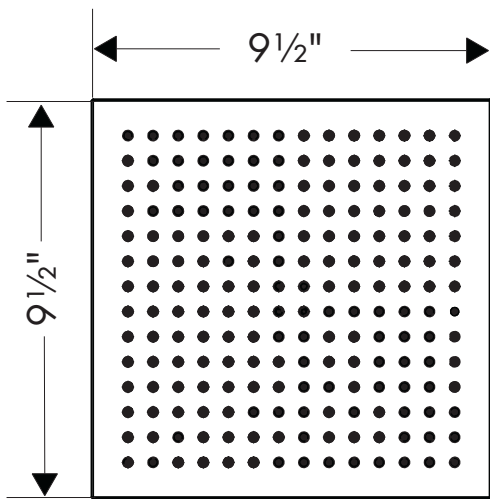

10926xx1

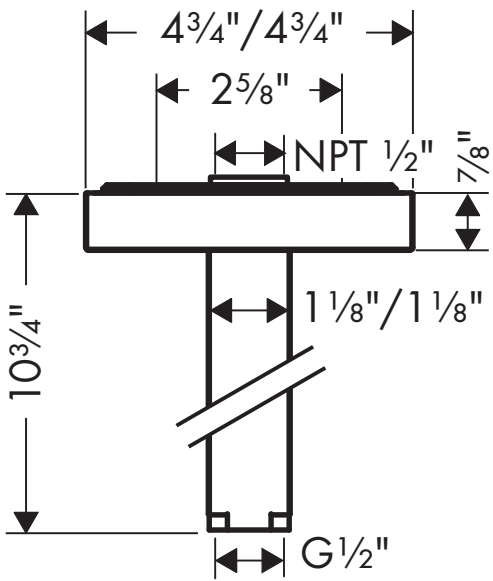

26414xx1

Roughing-In

Shower arm 26414xx1 requires a 1/2" NPT male nipple, recessed 3/16" above the surface of the finished ceiling.

Le bras de douche 26414xx1 nécessite l'utilisation d'un raccord mâle NPT de 1/2 po, encastré à 3/16 po (0,48 cm) au-dessus de la surface du plafond fini.

El brazo de ducha 26414xx1 requiere un niple macho NPT de 1/2", embutido 3/16" sobre la superficie del cielo raso acabado.

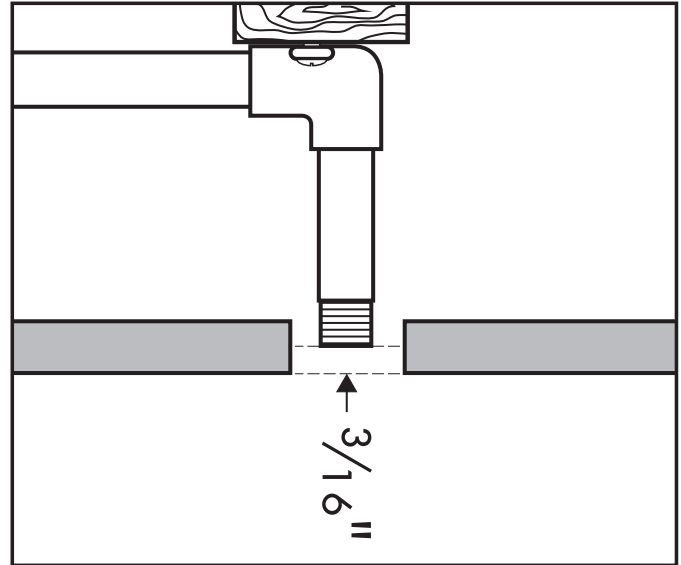

Tools Required / Outils Utiles / Herramientas Útiles

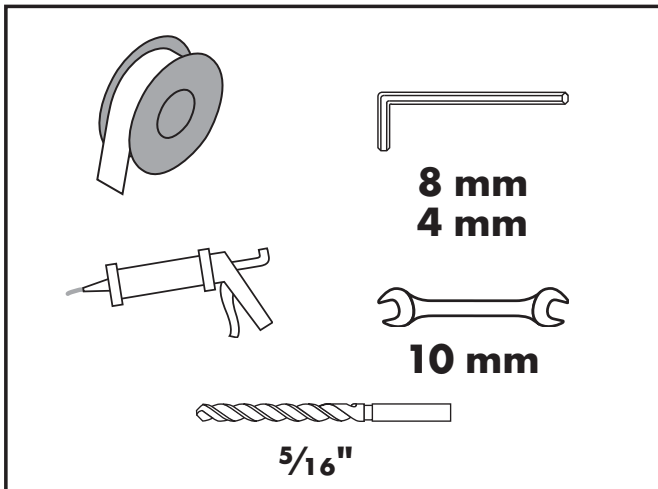

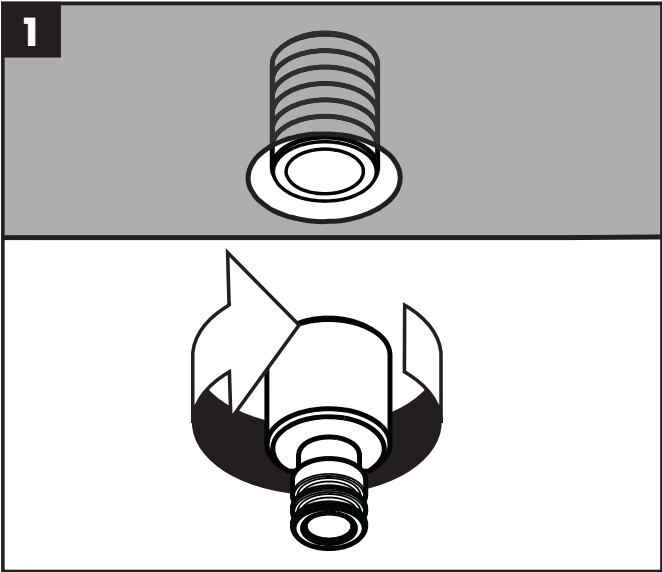

Installation

Install the connector on the nipple.

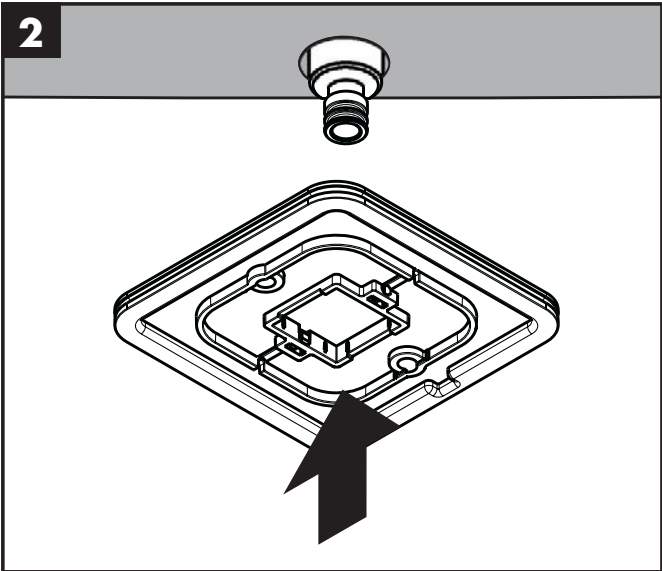

Push the anchor plate into place over the nipple.

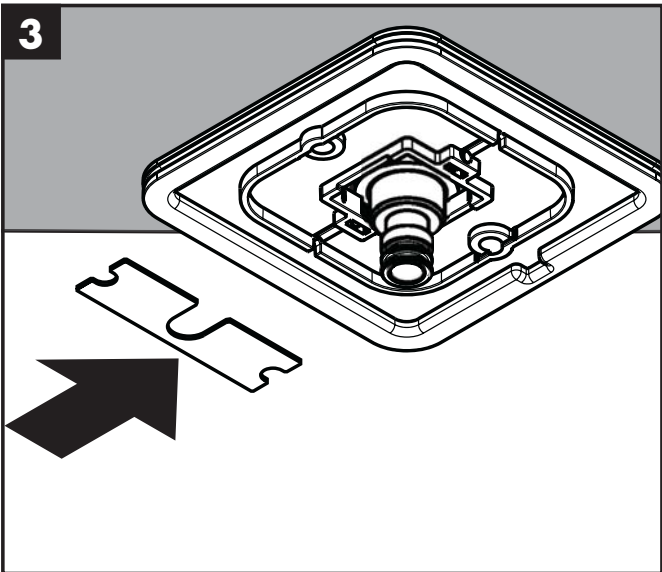

Install the retaining clip.

Installation

Installez le connecteur sur le raccord.

Instalación

Instale el conector en el niple.

Poussez la plaque d'encrage en place sur le raccord.

Coloque la placa de anclaje en su lugar sobre el niple.

Installez le clip de retenue.

Instale la presilla de retención.

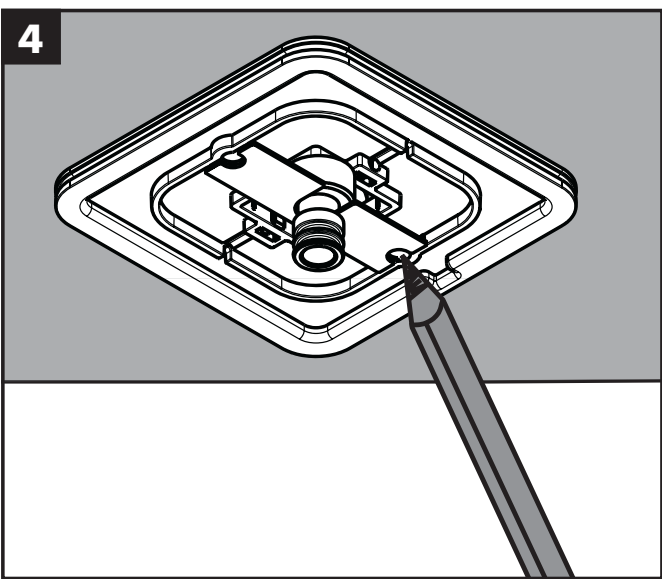

Mark the positions of the screw holes.

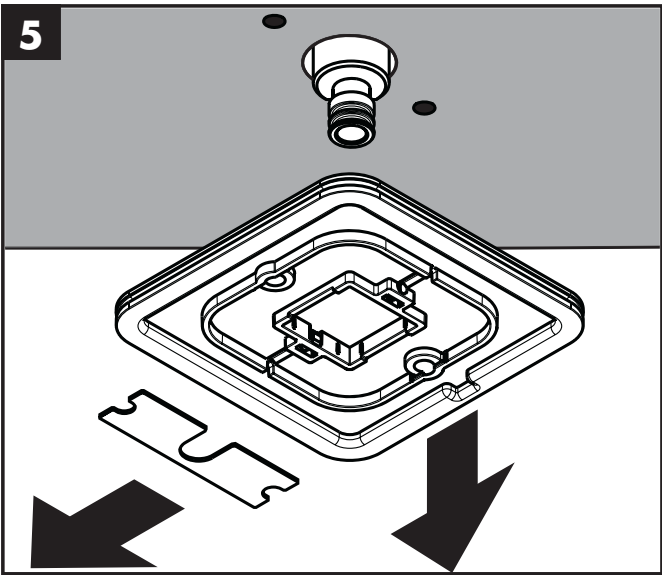

Remove the retaining clip and anchor plate.

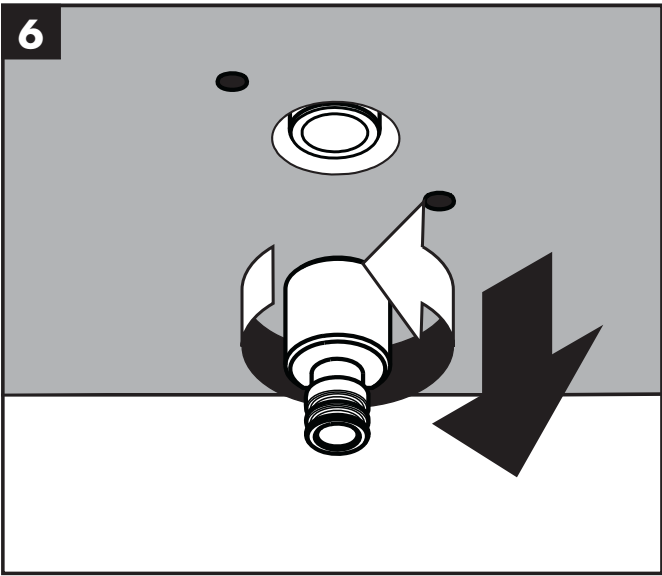

Remove the connector.

Marquez les positions des trous de vissage.

Marque las posiciones de los orificios para tornillos.

Enlevez le clip de retenue et la plaque d'ancrage.

Retire la presilla de retención y la placa de anclaje.

Retirez le connecteur.

Retire el conector.

English

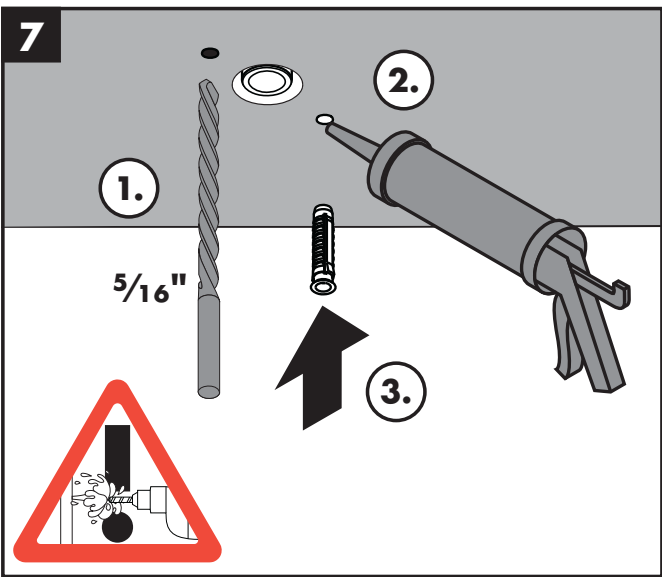

Drill the screw holes using a 5/16" bit.

Install the anchors.

Seal the ceiling around the anchors using waterproof sealant.

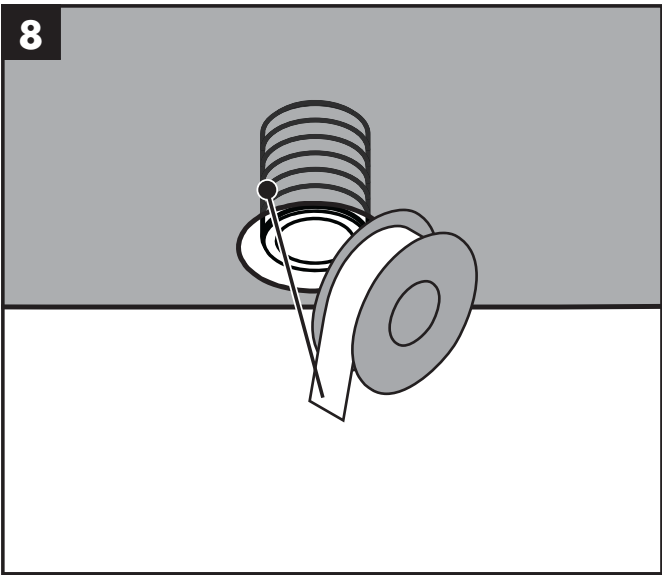

Wrap the threads on the nipple with plumbers tape.

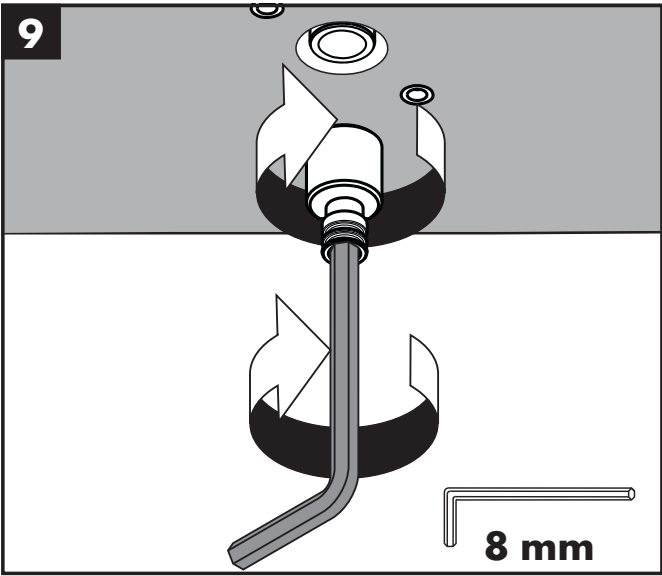

Install the connector.

Français

Percez les trous de vissage à l'aide d'une mèche de $\frac{5}{16}$ po (8 mm).

Installez les chevilles.

Scellez le plafond autour des chevilles à l'aide d'un agent d'étanchéité.

Español

Perfore los orificios para tornillos con una broca de $\frac{5}{16}$ ".

Instale los pernos de anclaje.

Selle el cielo raso alrededor de los pernos de anclaje con un sellador impermeable.

Enveloppez les filets du raccord fileté avec du ruban de filetage de plomberie.

Envuelva las roscas del niple con cinta de plomero.

Installez le connecteur.

Instale el conector.

English

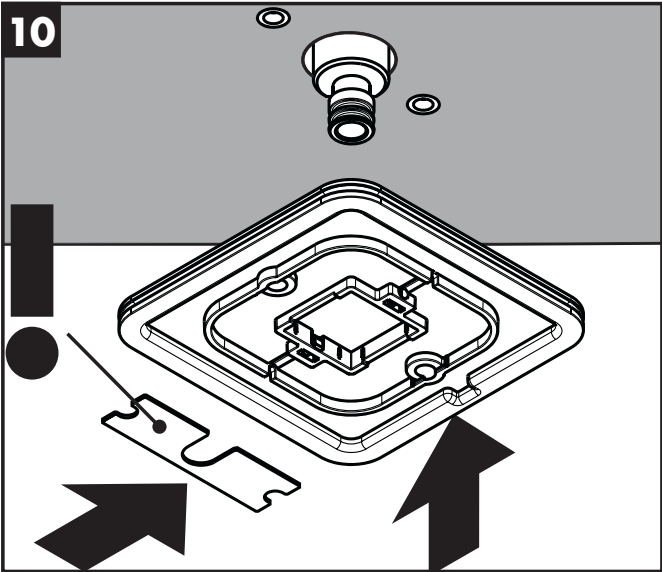

Install the anchor plate, lining the holes up with the screw holes in the ceiling.

Install the clip.

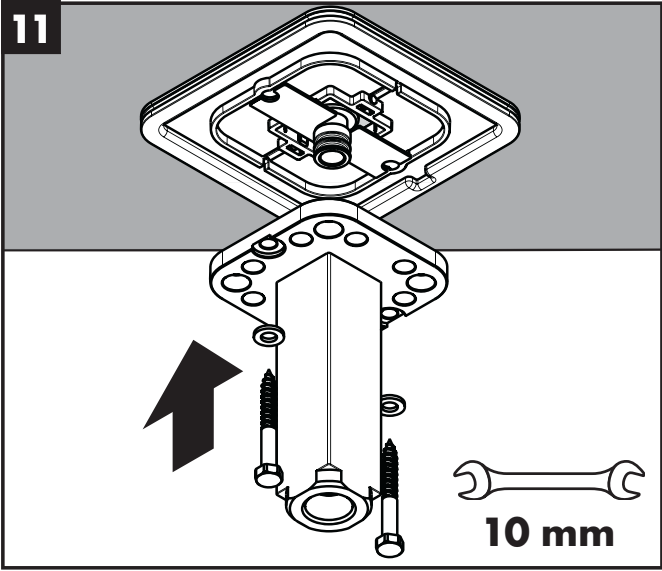

Install the shower arm.

Tighten the screws.

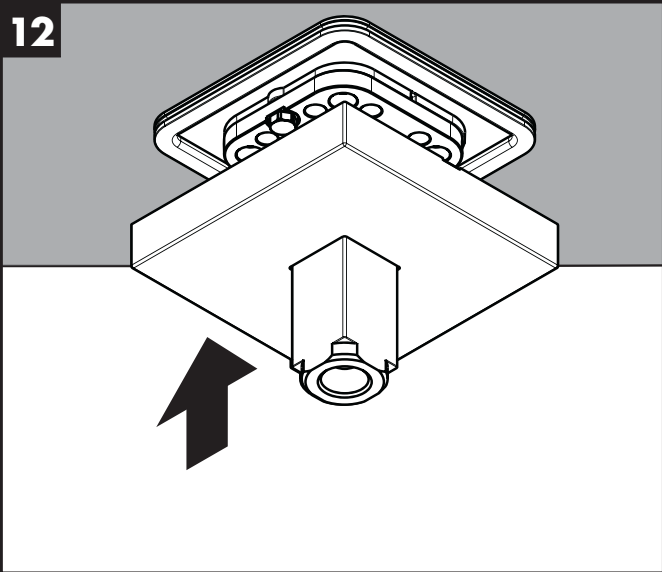

Install the escutcheon.

Français

Installez la plaque d'ancrage en alignant les trous avec les trous de vissage du plafond.

Installez le clip.

Installez le bras de douche.

Serrez les vis.

Installez l'écusson.

Español

Instale la placa de anclaje, alineando los orificios con los orificios para tornillos en el cielo raso.

Instale la presilla.

Instale el brazo de ducha.

Apriete los tornillos.

Instale el escudo.

10926xx1 Installation

Press inward on the retaining tabs.

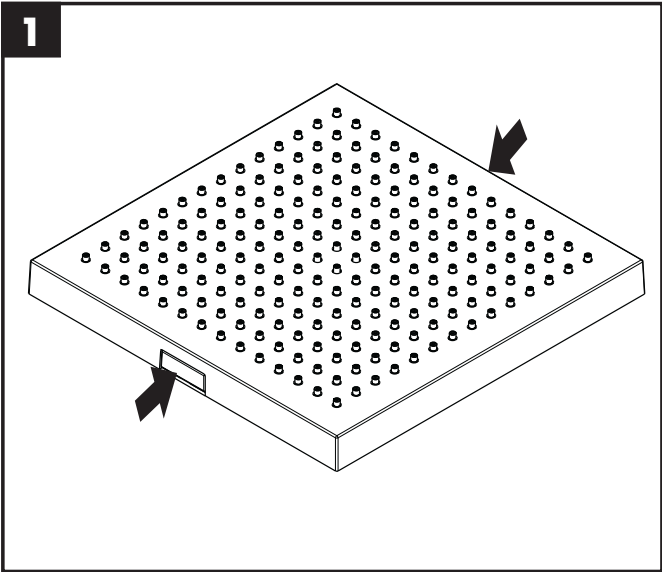

Cautiously remove the face plate, taking care not to damage the spray jets.

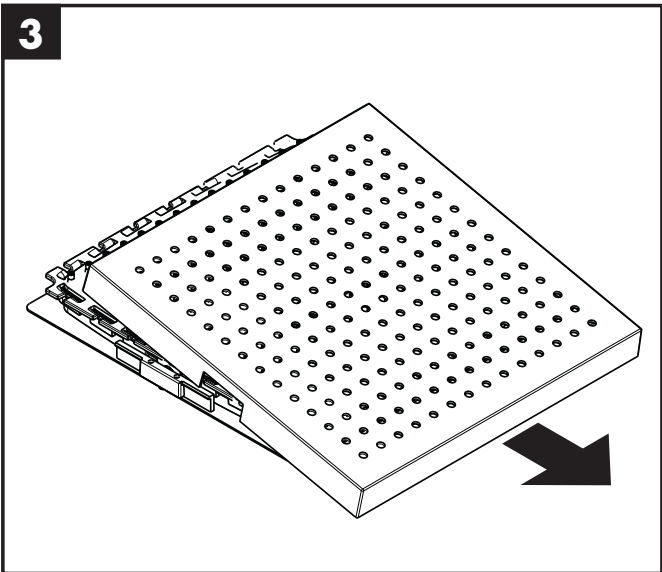
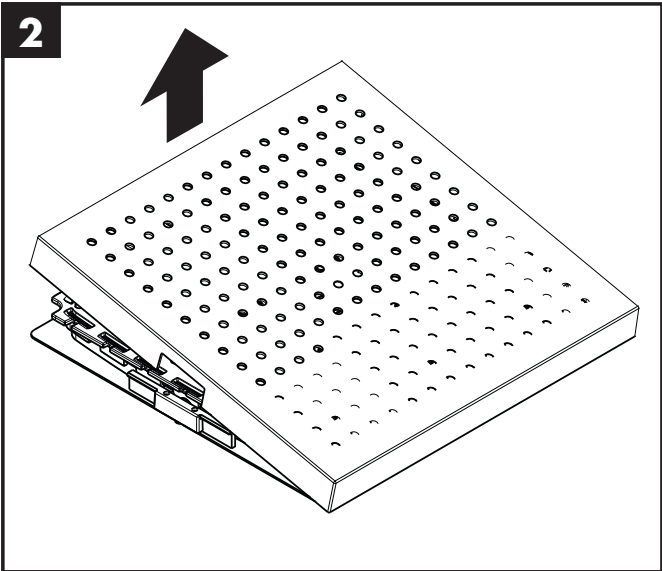

Installation 10926xx1

Poussez les languettes de retenue vers l'intérieur.

Retirez délicatement la plaque frontale pour ne pas endommager les buses de pulvérisation.

Instalación 10926xx1

Presione hacia adentro sobre las lengüetas de retención.

Retire con cautela la placa frontal, teniendo cuidado de no dañar los surtidores de ducha.

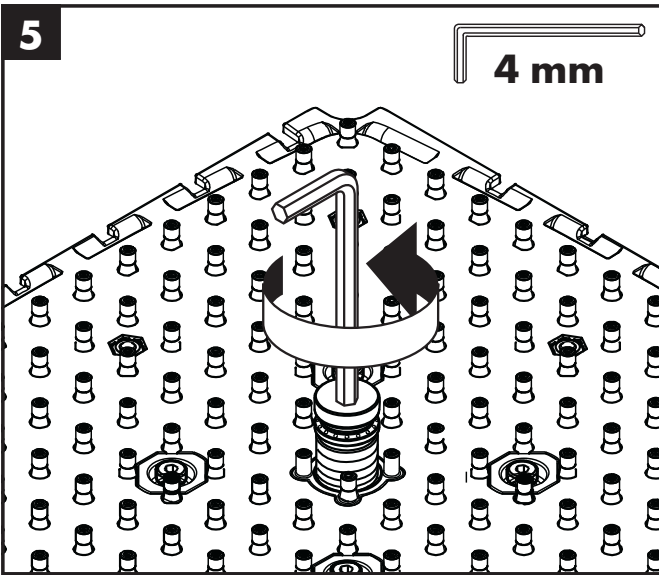
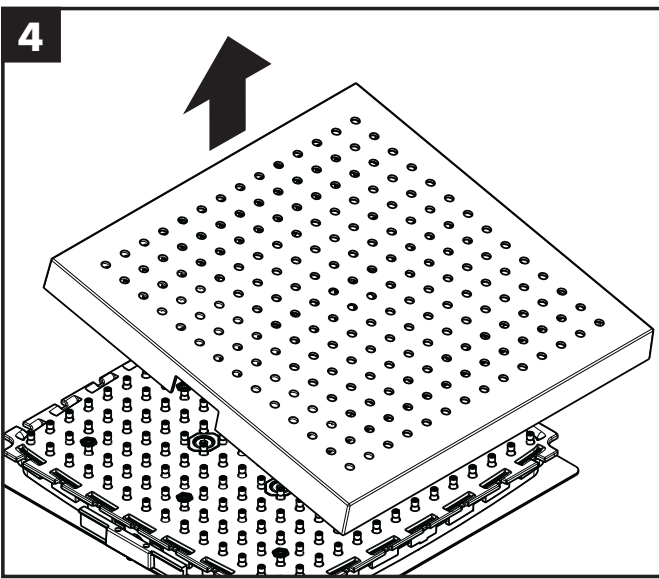

Remove the air jet.

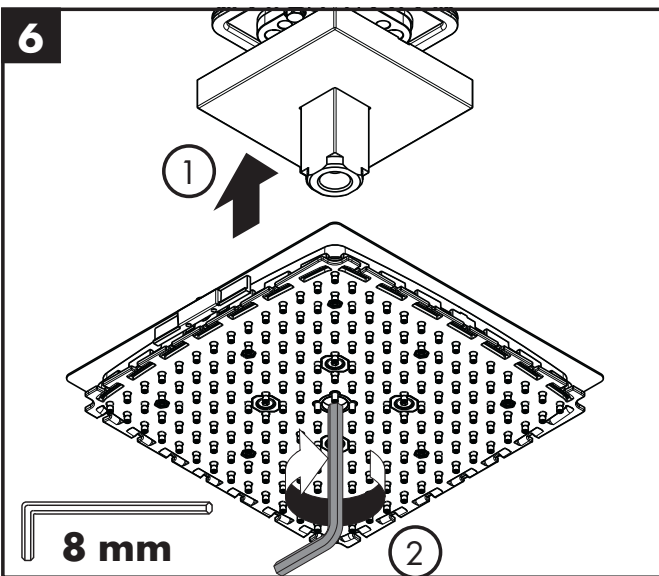

Connect the showerhead to the shower arm.

! Overtightening will cause damage to the showerhead and/or the shower arm.

Retirez la buse d'air.

Retire el surtidor de aire.

Connectez la pomme de douche au bras de douche.



Évitez de trop serrer car vous pourriez endommager la pomme de douche ou le bras de douche.

Conecte el cabezal de la ducha al brazo de ducha.



El ajuste excesivo dañará el cabezal de la ducha o el brazo de la ducha.

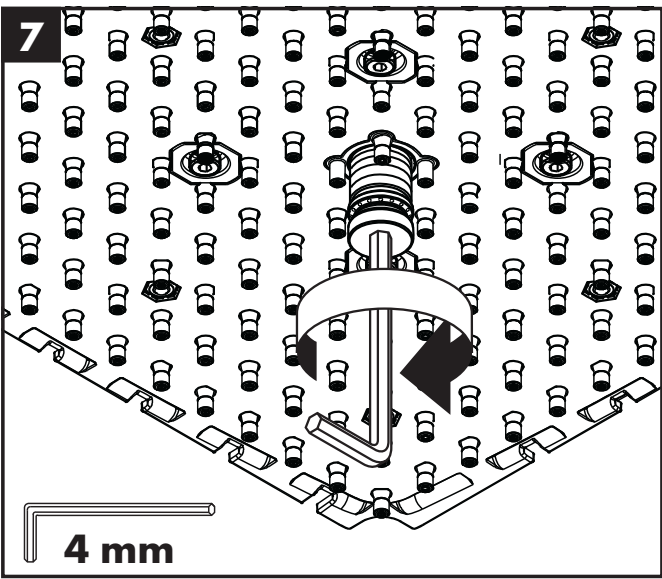

Install the air jet.



Over-tightening the air jet will cause damage to the showerhead.

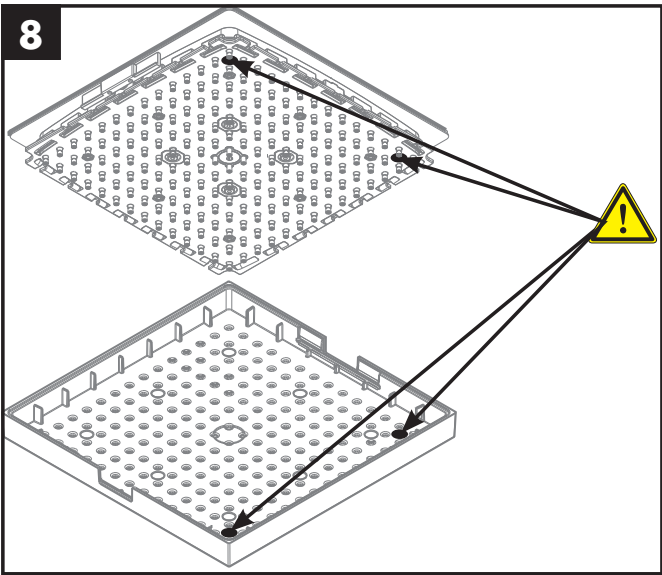

Align the markings on the face plate and spray body.

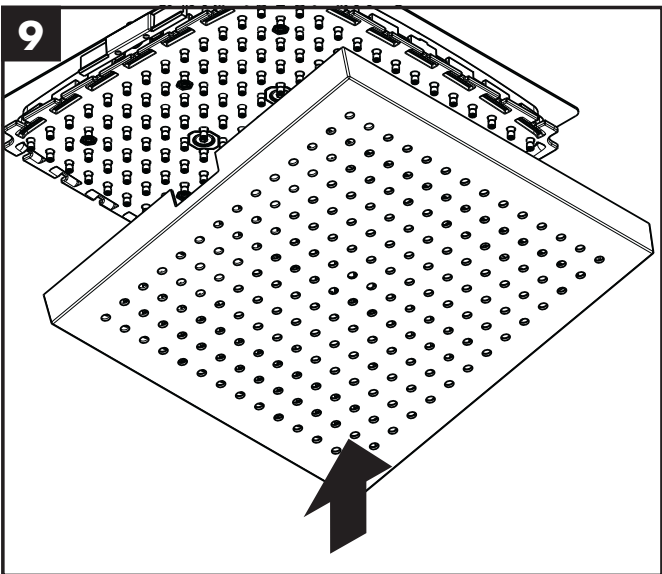

Install the face plate.

Français

Installez la buse d'air.



Évitez de trop serrer la buse d'air car vous pourriez endommager la pomme de douche.

Alignez les marques figurant sur la plaque frontale avec le corps de la buse.

Installez la plaque frontale.

Español

Instale el surtidor de aire.



El ajuste excesivo del surtidor de aire dañará el cabezal de la ducha.

Alinee las marcas en la placa frontal y el cuerpo de rociado.

Instale la placa frontal.

10

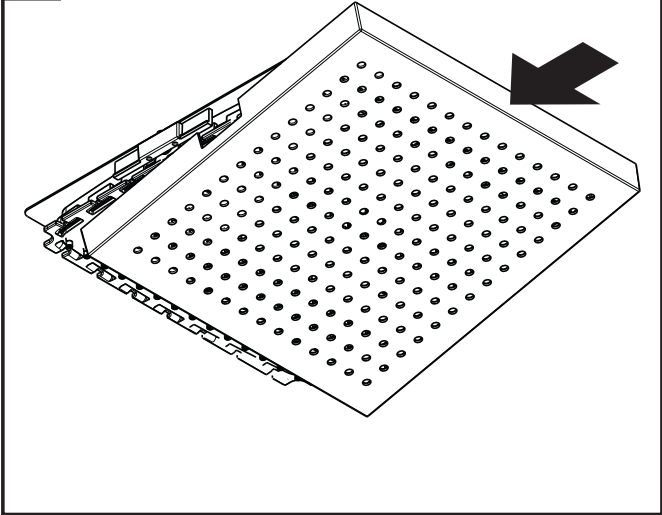

11

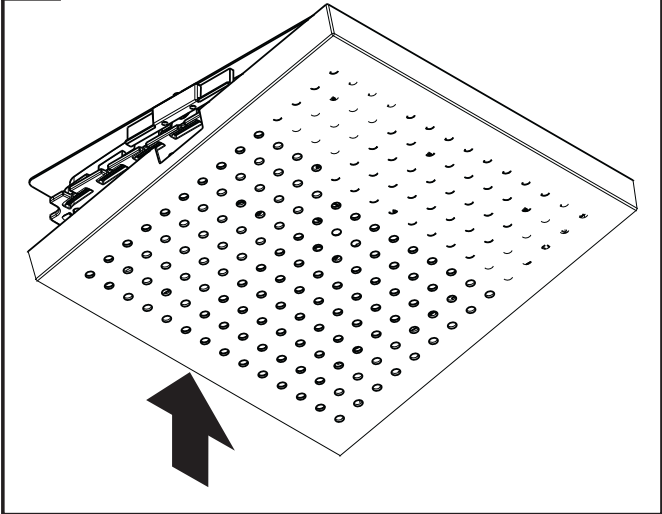

12

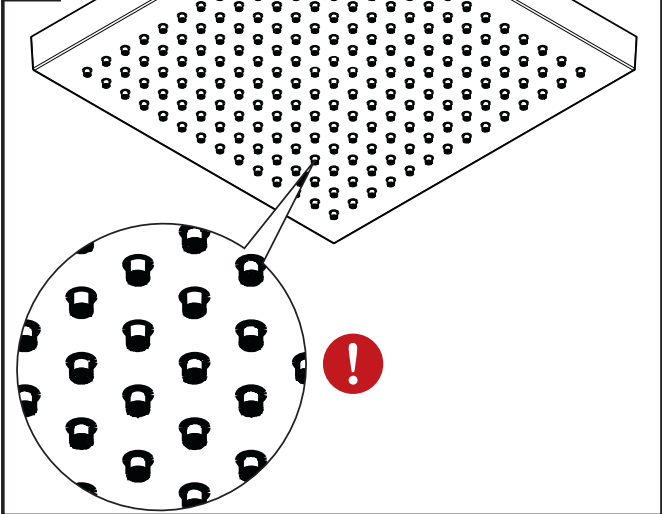

! The jets on the spray body must go through the holes on the face plate.

The locking tabs should click into place.



Les buses du corps de la buse doivent s'insérer dans les trous de la plaque frontale.

Les languettes de verrouillage devraient s'enclencher en place.



Los surtidores en el cuerpo de rociador deben pasar por los orificios en la placa frontal.

Las lengüetas de bloqueo deben calzar en su sitio.

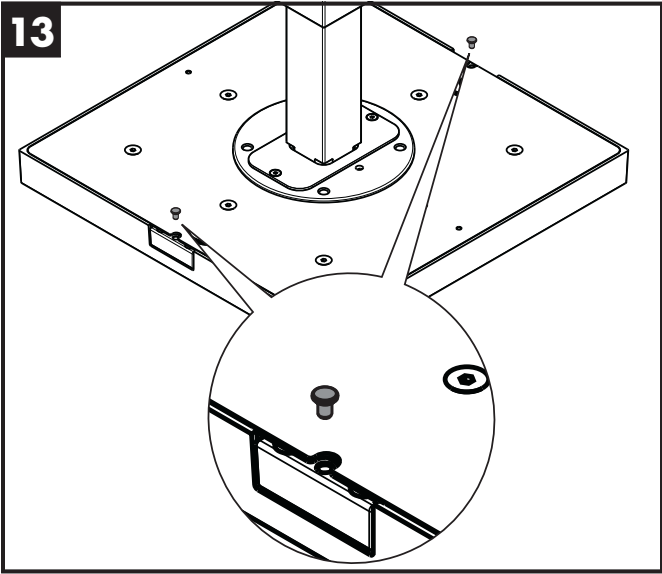

Install the screw covers.

Installez les cache-vis.

Instale las tapas de los tornillos.

Replacement Parts / Pièces détachées / Repuestos

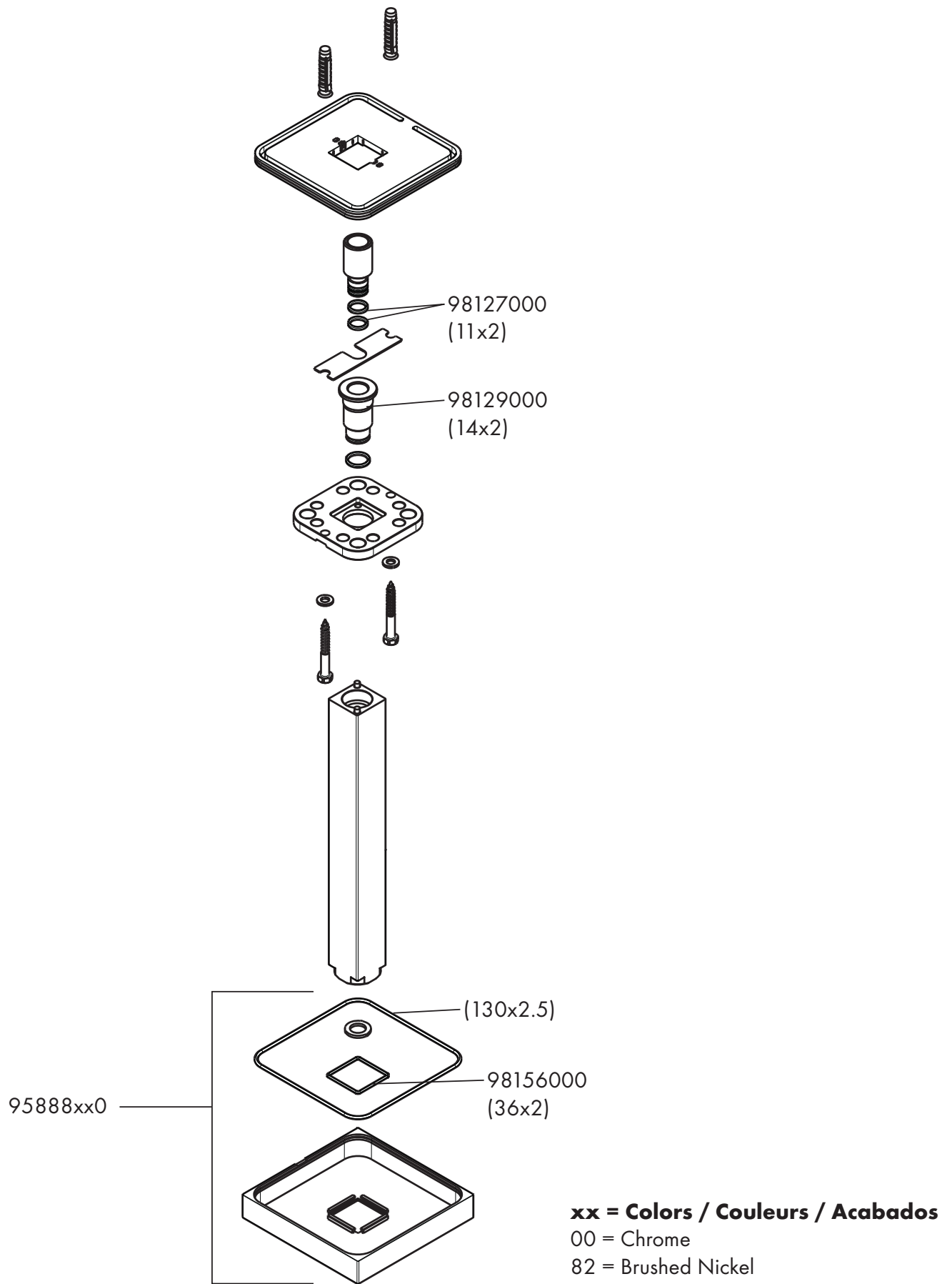

Replacement Parts / Pièces détachées / Repuestos

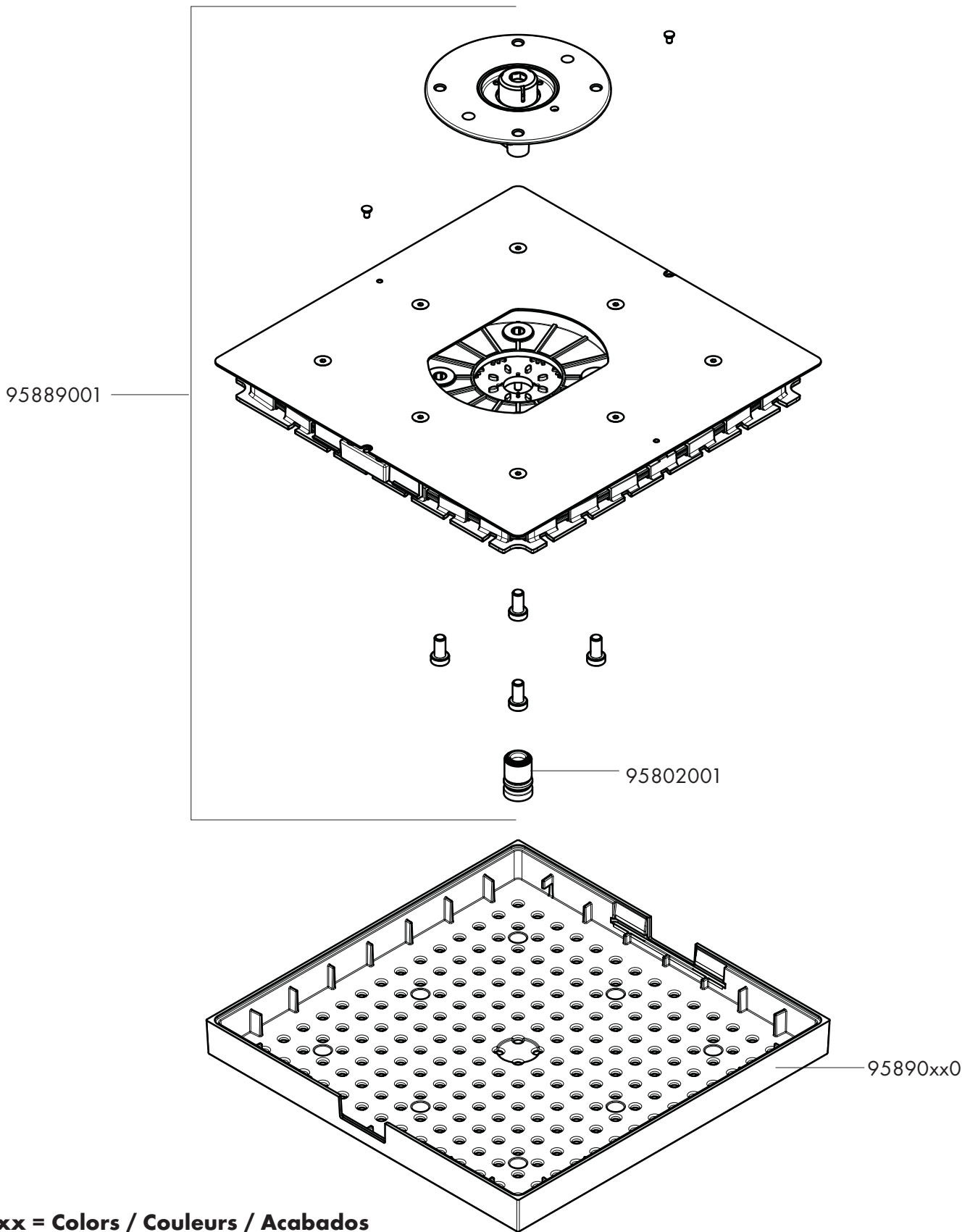

xx = Colors / Couleurs / Acabados

00 = Chrome

82 = Brushed Nickel

Cleaning / Nettoyage / Limpieza

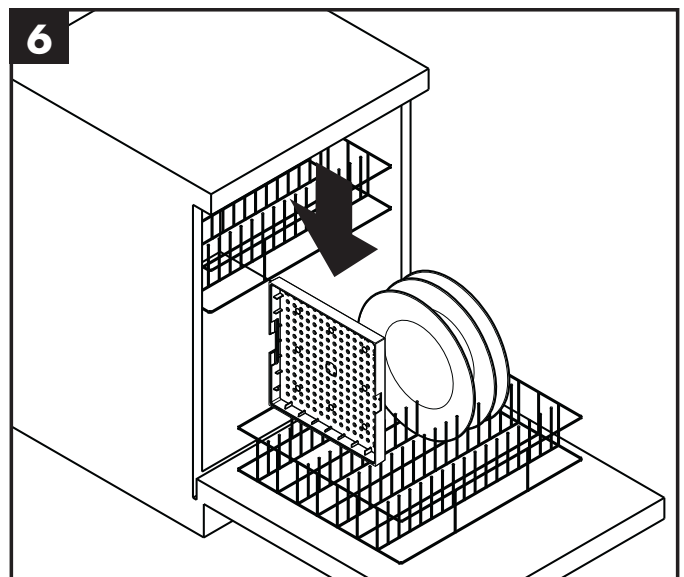
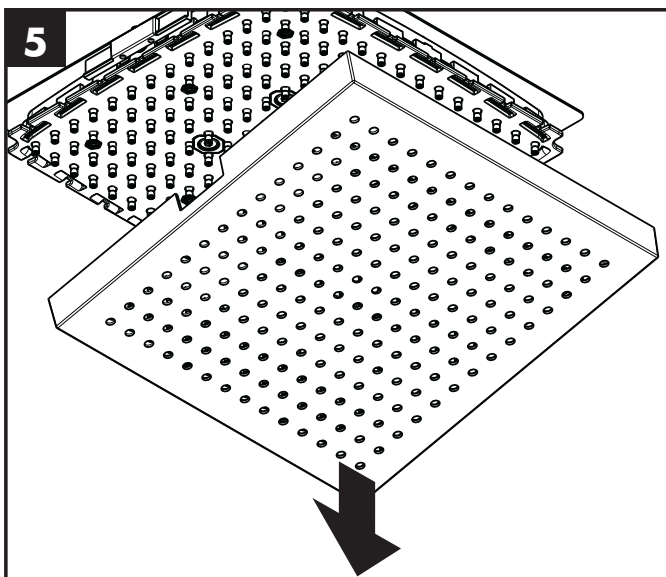
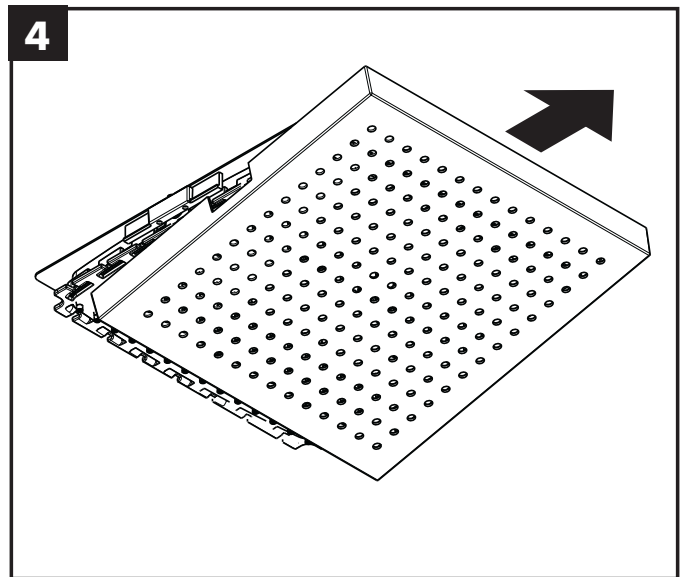
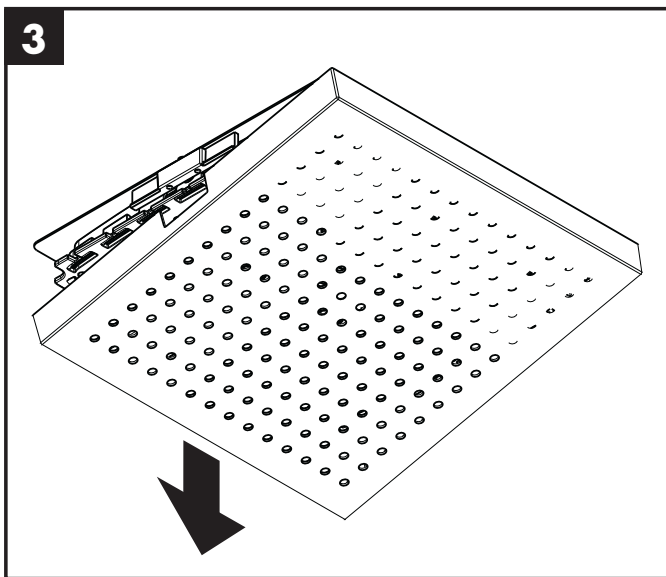
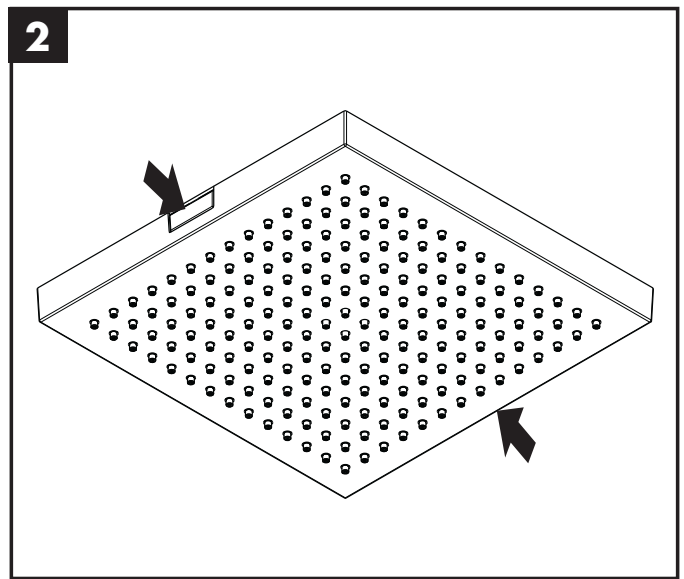
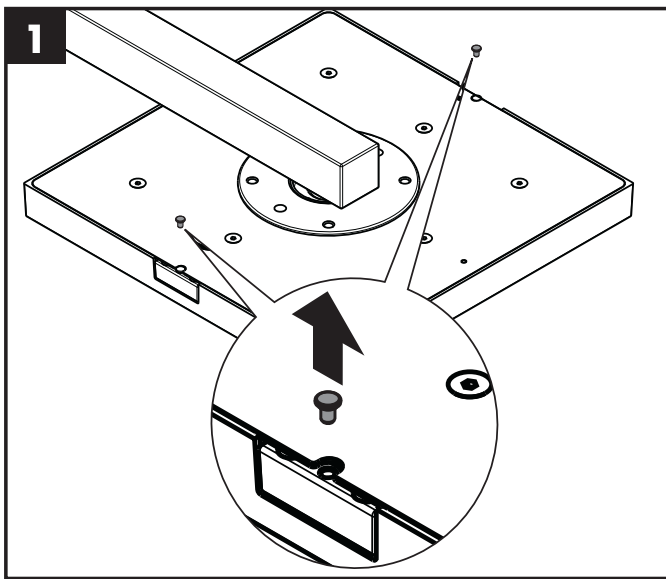

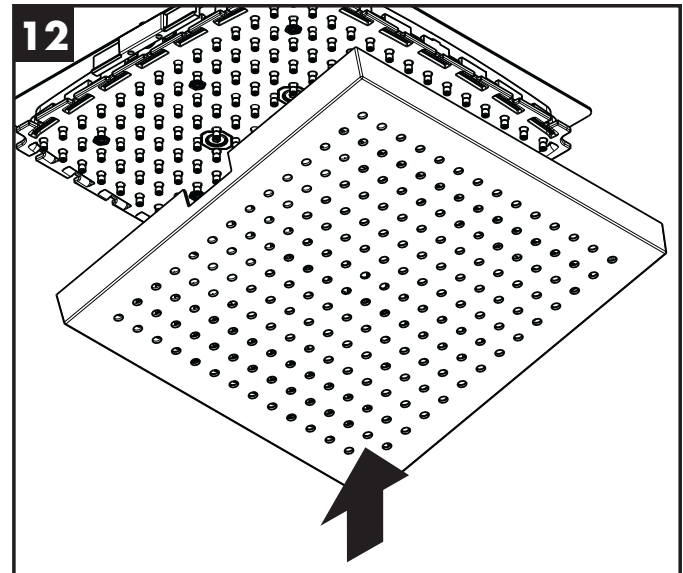
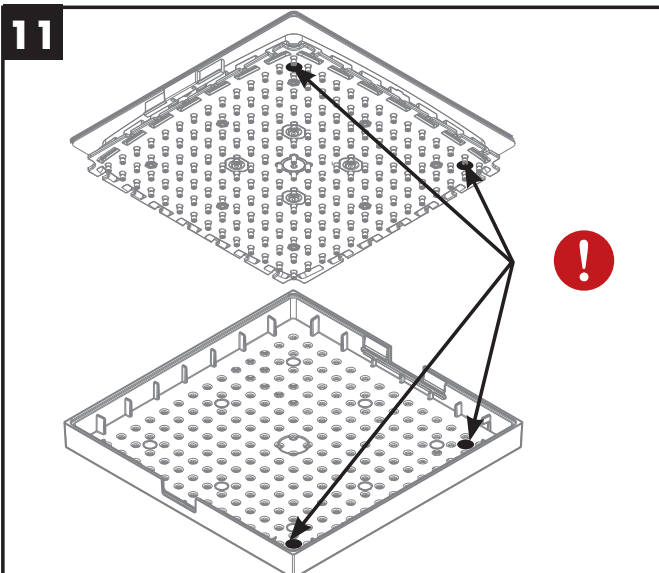
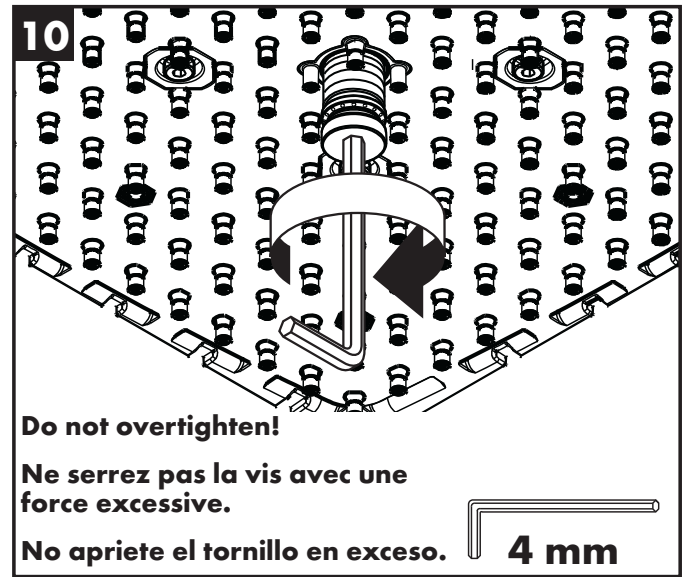
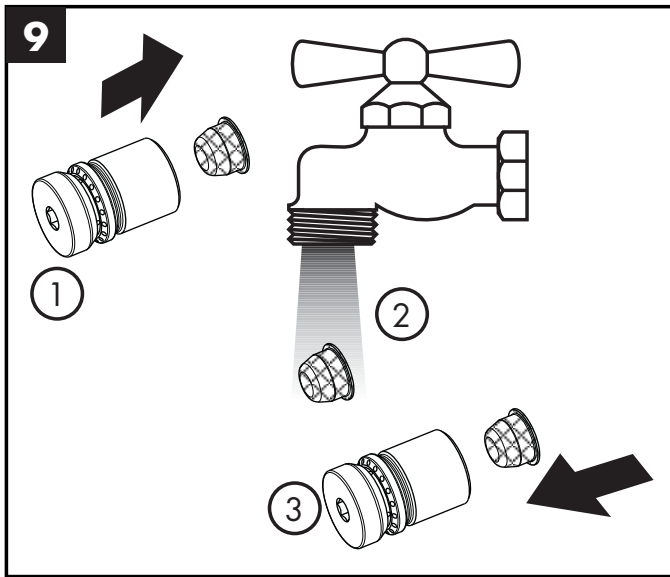
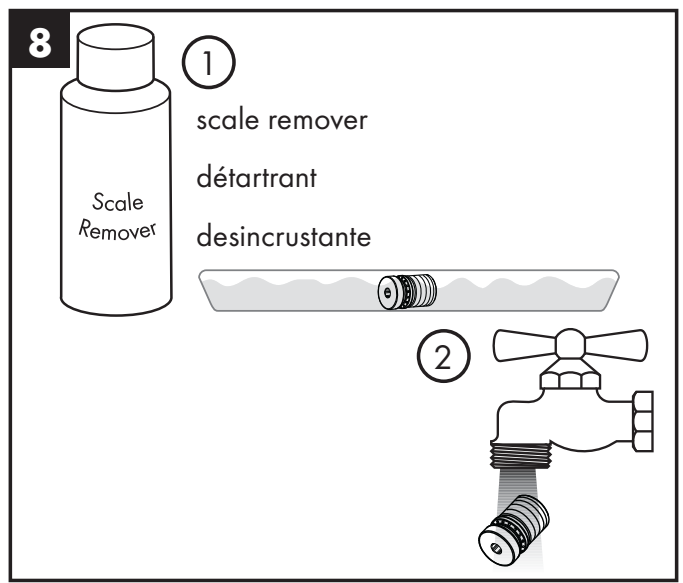
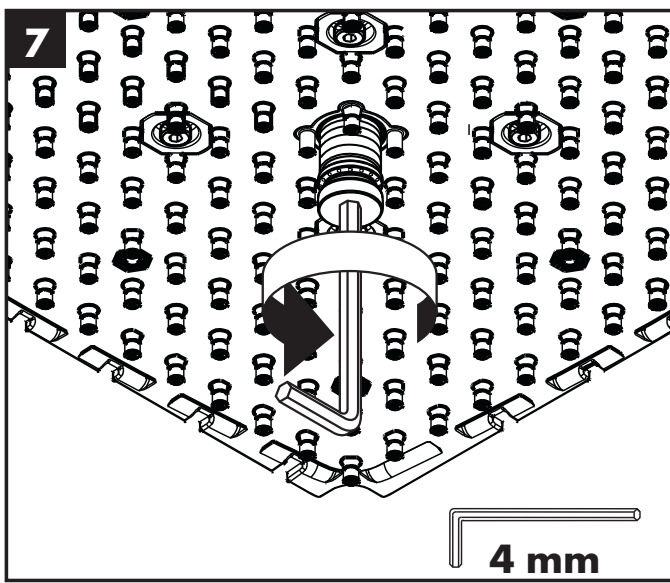

13

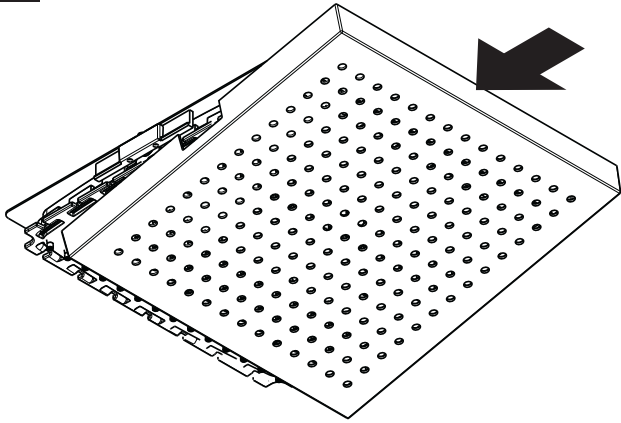

14

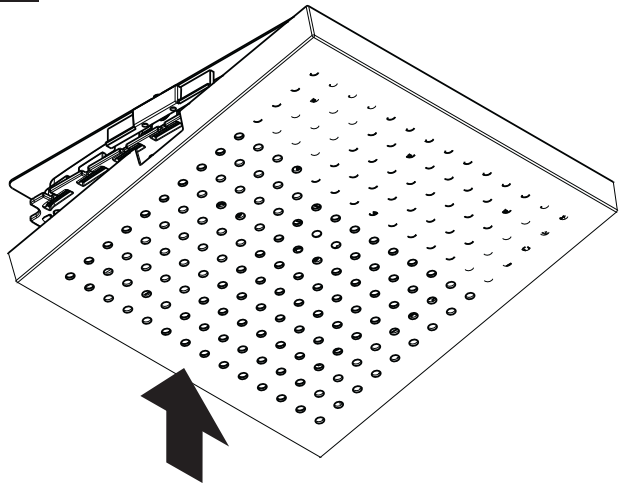

15

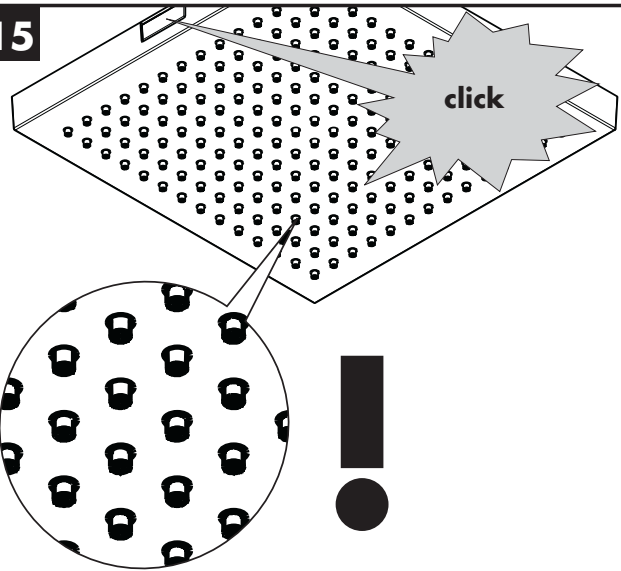

16

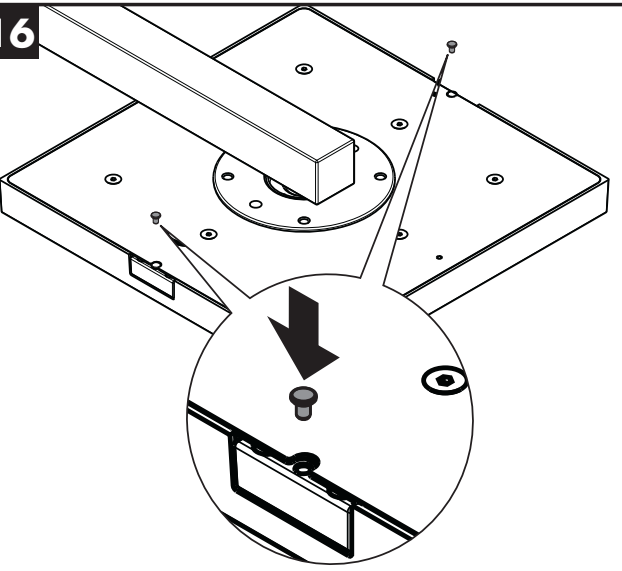

Cleaning Recommendation for Hansgrohe Products

Modern bathroom faucets, kitchen faucets and shower products are made from different materials to comply with the needs of the market with regard to design and functionality. To avoid damage to the product, it is necessary to take proper care of it.

For best results:

- Prevent the buildup of mineral scale and /or soap residue by cleaning your Hansgrohe product(s) when needed.
- Select a cleaning agent specifically intended for the type of product.
- **Do not** use these types of cleaners as they will cause damage to your Hansgrohe product:
 - ✘ Any cleaning agent containing hydrochloric acid, formic acid, lye, or acetic acid.
 - ✘ Abrasive cleaning powders, pads, or brushes.
 - ✘ Steam cleaners.
 - ✘ "No rinse" cleaning agents.
- **Always** follow the instructions provided by the manufacturer of the cleaning agent.
- **Do not** mix cleaning agents, unless directed by the manufacturer.
- **Do not** spray cleaners directly onto the product as drops could enter openings and gaps and cause damage. When using spray cleaners, spray the cleaner onto a soft cloth or sponge.
- **Always** rinse your Hansgrohe product thoroughly with clear water and polish dry with a soft cloth after cleaning.

Important

- Residue from soaps and shampoos can cause damage. Rinse the product with clean water after each use.
- Residue from basin/tub/tile cleaner can cause damage to faucets and fittings. Immediately rinse any overspray from the Hansgrohe product.
- **Damage to the product caused by improper care or the use of improper cleaning agents is not covered by the warranty.**
- **If a component of the product is damaged, replace it, as there is risk of injury.**

Conseil de nettoyage pour les produits Hansgrohe

De nos jours le sanitaire moderne, la robinetterie et les douchettes se composent de matériaux très différents pour satisfaire à la demande concernant le design et la fonctionnalité. Pour éviter les détériorations et les réclamations, aussi bien pour l'utilisation que pour le nettoyage prochain, certains critères seront à prendre en considération.

A prendre en considération lors de l'entretien de la robinetterie et de douchettes:

- On doit seulement utiliser les produits de nettoyage qui sont formellement prévus pour ce domaine.
- Aucun contact avec l'application de nettoyeurs contenant de l'acide chlorhydrique, de l'acide formique ou de l'acide acétique qui peuvent causer de considérables détériorations.
- Les nettoyeurs à base d'acide phosphorique, aussi, ne sont pas à utiliser sans réserves.
- Le mélange de nettoyeurs en général n'est pas autorisé.
- L'utilisation de produits de nettoyage récurants et des ustensiles comme des frottoirs, des éponges à récurer et des torchons microfibrés est exclue.
- Les conseils d'entretien des producteurs de nettoyeurs sont à suivre obligatoirement.
- Le nettoyage est à faire correspondre avec le dosage, le temps d'action, spécifique à l'objet et à la nécessité.
- Le dépôt de calcaire est évité par un nettoyage régulier.

-
- Pour le nettoyage avec produit vaporisé liquide, en aucun cas sur la robinetterie, mais au contraire aspergé sur le chiffon (torchon, éponge) et effectuer comme cela le nettoyage, car les aérosols peuvent pénétrer dans les ouvertures et fentes de la robinetterie et peuvent provoquer des détériorations.
 - Après le nettoyage rincez avec suffisamment d'eau claire pour éliminer les restes de produits attachés.
 - L'utilisation d'appareil de nettoyage à vapeur n'est pas autorisée, car les températures importantes peuvent détériorer les produits.

Indications importantes

- Les produits pour le corps comme les savons liquides, les shampooings ou les gels de douche peuvent causer des détériorations.
- Ici aussi on doit: Après l'utilisation rincer soigneusement les restes avec de l'eau.

Conseil de nettoyage

- **Les détériorations imputables à un mauvais entretien ne peuvent être pris en considération par notre garantie.**
- Par l'action d'un nettoyant sur les revêtements déjà endommagé il se produit une aggravation des dégâts.

Recomendación de limpieza para los productos de Hansgrohe

Hoy en día, las griferías de baño y de cocina así como duchas modernas se componen de materiales muy distintos para satisfacer las exigencias del mercado respecto al diseño y la funcionalidad. Para evitar daños y reclamaciones hay que tener en cuenta ciertos aspectos tanto en el uso como en su limpieza.

Para el cuidado de las griferías y las duchas en principio hay que seguir lo siguiente:

- Usar sólo detergentes previstos específicamente para este campo de aplicación.
- No aplicar detergentes que contengan ácido clorhídrico, fórmico o acético porque pueden causar daños importantes.
- Detergentes que contienen ácido fosfórico tampoco pueden ser aplicados ilimitadamente. Por regla general no se deben mezclar detergentes.
- Tampoco se deben utilizar utensilios abrasivos, como son polvos abrasivos, esponjas o paños de microfibra.
- Se tienen que seguir siempre las sugerencias de empleo de los fabricantes de los detergentes.
- La limpieza tiene que ser realizada según la dosificación y el tiempo de actuación, en función del objeto y ajustada a las necesidades específicas del mismo.
- Gracias a una limpieza periódica se pueden evitar los depósitos de cal.
- No conviene rociar el detergente en ningún caso sobre la grifería sino sobre los textiles y ejecutar la limpieza así, porque el líquido puede entrar en aperturas o hendiduras de la grifería y causar daños.
- Después de la limpieza hay que aclarar con suficiente agua para eliminar completamente el resto de detergente.
- La utilización de limpiadores a vapor no está permitida, las altas temperaturas pueden dañar los productos.

Indicaciones importantes

- Los residuos de productos de aseo como jabón líquido, champús y gel de ducha pueden dañar también los materiales.
- Por lo que también se deberá prestar atención a lo siguiente: aclarar con abundante agua después del uso.
- Con materiales ya dañados la acción de detergentes incrementará el desgaste de estos.
- **Los componentes con superficies dañadas deberán cambiarse, en otro caso se corre el peligro de lesionarse.**
- Los daños que resulten de un uso inadecuado no están incluidos en nuestra garantía.

Limited Consumer Warranty

This product has been manufactured and tested to the highest quality standards by Hansgrohe, Inc. ("Hansgrohe"). This warranty is limited to Hansgrohe products that are purchased by a consumer in the United States or Canada after March 1, 1996, and installed in either in the United States or in Canada.

WHO IS COVERED BY THE WARRANTY

This warranty extends to the original purchaser only. This warranty is non-transferable.

WHAT IS COVERED BY THE WARRANTY

The warranty covers only your Hansgrohe manufactured product. Hansgrohe warrants this product against defects in material or workmanship as follows:

Hansgrohe will replace at no charge for parts only or, at its option, replace any product or part of the product that proves defective because of improper workmanship and/or material, under normal installation, use, service and maintenance. If Hansgrohe is unable to provide a replacement and repair is not practical or cannot be made in timely fashion, Hansgrohe may elect to refund the purchase price in exchange for the return of the product.

LENGTH OF WARRANTY

Replacement or repaired parts of products will be covered for the term of this warranty, as stated in the following two sentences. If you are a consumer who purchased the product for use primarily for personal, family or household purposes, this warranty extends for as long as you own the product and the home in which the product is originally installed. If you purchased the product for use primarily for any other purpose, including, without limitation, a commercial purpose, this warranty extends only (i) for 1 year, with respect to Hansgrohe & Commercial products, and (ii) for 5 years, with respect to Axor products.

THIS WARRANTY DOES NOT COVER, AND HANSGROHE WILL NOT PAY FOR:

- A. Conditions, malfunctions or damage not resulting from defects in material or workmanship.
- B. Conditions, malfunctions or damage resulting from (1) normal wear and tear, improper installation, improper maintenance, misuse, abuse, negligence, accident or alteration; (2) the use of abrasive or caustic cleaning agents or "no-rinse" cleaning products, or the use of the product in any manner contrary to the product instructions; or (3) conditions in the home such as excessive water pressure or corrosion.
- C. Labor and other expenses for disconnection, deinstallation, or return of the product for warranty service (including but not limited to proper packaging and shipping costs), or for installation or reinstallation of the product.
- D. Accessories, connected materials and products, or related products not manufactured by Hansgrohe.
- E. Any Hansgrohe or Axor product sold for display purposes.
- F. Rubbed Bronze finish is subject to a 3-year limited warranty. Chrome and all PVD finishes are covered by the limited lifetime warranty.
- G. Hansgrohe Water Filtration System is subject to a 1-year limited warranty. Warranty does not include replacement filters.

TO OBTAIN WARRANTY PARTS OR INFORMATION

Contact your Hansgrohe retailer, or contact Technical Service at:

Hansgrohe, Inc.
1492 Bluegrass Lakes Parkway
Alpharetta, GA 30004
Toll-free 800-334-0455

In requesting warranty service, you will need to provide:

1. The sales receipt or other evidence of the date and place of purchase.
2. A description of the problem.
3. Delivery of the product or the defective part, postage prepaid and carefully packed and insured, to:

Hansgrohe, Inc.
1492 Bluegrass Lakes Parkway
Alpharetta, GA 30004
Toll-free 800-334-0455

When warranty service is completed, any repaired or replacement product or part will be returned to you postage prepaid.

EXCLUSIONS AND LIMITATIONS

REPAIR OR REPLACEMENT (OR, IN LIMITED CIRCUMSTANCES, REFUND OF THE PURCHASE PRICE) AS PROVIDED UNDER THIS WARRANTY IS THE EXCLUSIVE REMEDY OF THE PURCHASER. HANSGROHE NEITHER ASSUMES NOR AUTHORIZES ANY PERSON TO CREATE FOR IT ANY OTHER OBLIGATION OR LIABILITY IN CONNECTION WITH THIS PRODUCT. HANSGROHE SHALL NOT BE LIABLE TO PURCHASER OR ANY OTHER PERSON FOR ANY INCIDENTAL, SPECIAL OR CONSEQUENTIAL DAMAGES, ARISING OUT OF BREACH OF THIS WARRANTY OR ANY IMPLIED WARRANTY (INCLUDING BUT NOT LIMITED TO ANY IMPLIED WARRANTY OF MERCHANTABILITY).

Some States do not allow the exclusion or limitation of incidental or consequential damages, so the above limitation or exclusion may not apply to you. This warranty gives you specific legal rights, and you may also have other rights that vary from state to state.

TO THE EXTENT PERMITTED BY LAW, ANY IMPLIED WARRANTIES OF MERCHANTABILITY AND FITNESS FOR A PARTICULAR PURPOSE, ARE LIMITED TO THE DURATION OF THE EXPRESS WARRANTY.

Some states do not allow limitations on how long an implied warranty may last, so the above limitations may not apply to you. You may be required by law to give us a reasonable opportunity to correct or cure any failure to comply before you can bring any action in court against us under the Magnuson-Moss Warranty Act.

PRODUCT INSTRUCTIONS AND QUESTIONS

Upon purchase or prior to installation, please carefully inspect your Hansgrohe product for any damage or visible defect. Prior to installing, always carefully study the enclosed instructions on the proper installation and the care and maintenance of this product. If you have questions at any time about the use, installation or performance of your Hansgrohe product, or this warranty, please write us or call us toll-free at 800-334-0455.

hansgrohe

Hansgrohe, Inc. • 1490 Bluegrass Lakes Parkway • Alpharetta, GA 30004
Tel. 800-334-0455 • Fax 770-360-9887

www.hansgrohe-usa.com