



TARA ULTRA HOT & COLD WATER DISPENSER - Brushed Dark Platinum

17 861 875 Product version from 5/28/2022



- 5-3/4" Projection
- Rigid, thermally insulated spout
- Laminar stream
- Total height 11-3/8"
- 7-1/8" height to aerator/spout outlet
- 1-3/8" hole diameter
- Provides filtered, hot water, 199°F max. temperature
- Provides filtered, cold water (not chilled)
- Water flow rate limited to max. 0.5 gpm
- control unit for wall assembly (5-3/8" x 6-1/4" x 2-3/8")
- electronic valve
- plug-in power supply, 100-230 V, 50-60 Hz, 18 W, incl. country-specific adaptor set
- lead-free
- One lever for hot and cold water
- Spout ring cannot be removed.
- This product can help a building meet the requirements of Green Building Rating Systems, e.g. LEED®, BREEAM®, DGNB

(ADA)

NOTE: Not compatible with Reverse Osmosis

Compatible with Insinkerator® hot water tank HWT300-F3000S. Tank and filter not supplied from Dornbracht. More information on tank and filter at www.insinkerator.com.

The installation must be above a kitchen sink.

We recommend replacing the filter cartridge every six months. Please see the installation manual for more information.

Specification and technical data sheets can be found on www.dornbracht.com/professional

	Brushed Dark Platinum	17 861 875-99
	Chrome	17 861 875-00
	Brushed Platinum	17 861 875-06
	Platinum	17 861 875-08
	Durabronze (23kt Gold)	17 861 875-09
	Dark Chrome	17 861 875-19
	Brushed Durabronze (23kt Gold)	17 861 875-28
	Matte Black	17 861 875-33
	Brushed Champagne (22kt Gold)	17 861 875-46
	Champagne (22kt Gold)	17 861 875-47
	Brushed Chrome	17 861 875-93



TARA ULTRA HOT & COLD WATER DISPENSER - Brushed Dark Platinum

17 861 875 Product version from 5/28/2022

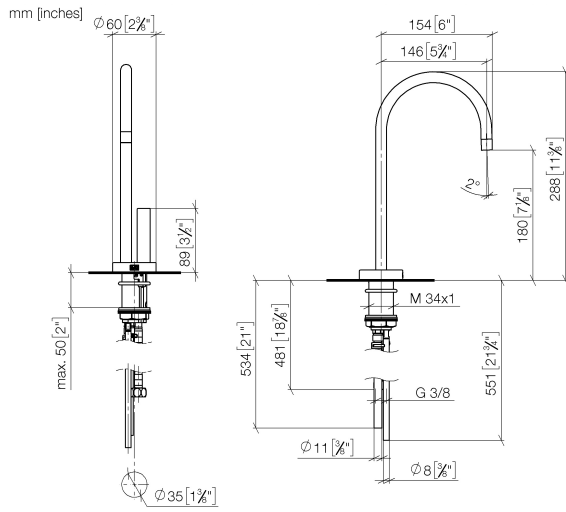

Flow rate chart

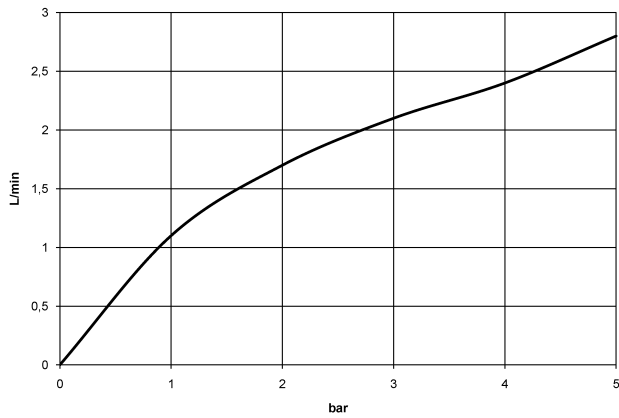

Codes & Standards

ADA	ASME A112.18.1	ASME A112.18.1/CSA B125.1	California Energy Commission (CEC)
cUPC	DIN 4109	Executive Order no. 1007	ISO 3822
NSF/ANSI 372	NSF/ANSI/CAN 61	NSF372	NSF61

Ü-Zeichen



TARA ULTRA HOT & COLD WATER DISPENSER - Brushed Dark Platinum

17 861 875 Product version from 5/28/2022

Certificates

IAPMO_N-4

IAPMO_4976

GDV_0400

LGA_28

IAPMO_6

TARA ULTRA HOT & COLD WATER DISPENSER - Brushed Dark Platinum

17 861 875 Product version from 5/28/2022

Parts for other finishes can be found here: [Chrome](#)

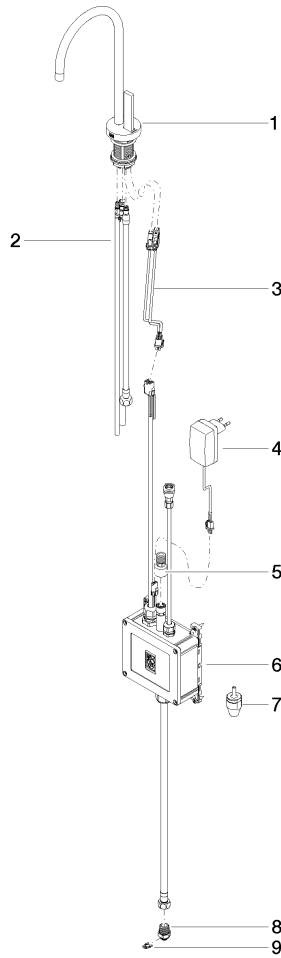

Spare parts list

Number	Item Number	Designation	Number of units	Lead time
1	90 17 85 100 05-99	fitting	1	20
2	90 30 04 067 00 90	hose	1	2
3	90 10 01 048 00 90	electronic accessories	1	2
4	04 10 01 246 00 90	electronic accessories	1	2
5	12 866 970 90	adaptor	1	2
6	90 11 11 064 01 90	electronic accessories	1	2
7	90 24 04 291 00 90	insert	1	2
8	09 24 04 293 90	nipple	1	2
9	09 16 01 045 90	ring	1	2