

1 APPLY LOCTITE 680 OR EQUIVALENT.

BILL OF MATERIAL (CURRENT LEVEL)				
ITEM	PT/ASSY	DESCRIPTION	TYPE	QTY.
1	10956	HANDLE BASE	PART	1
2	92000	SCREW 8 - 32 X 1/8 SS	PART	2
3	11337	TAPERED LEVER HANDLE	PART	1

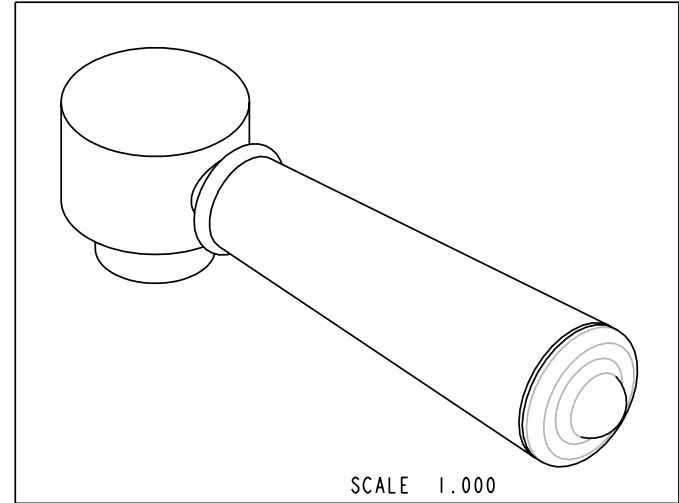
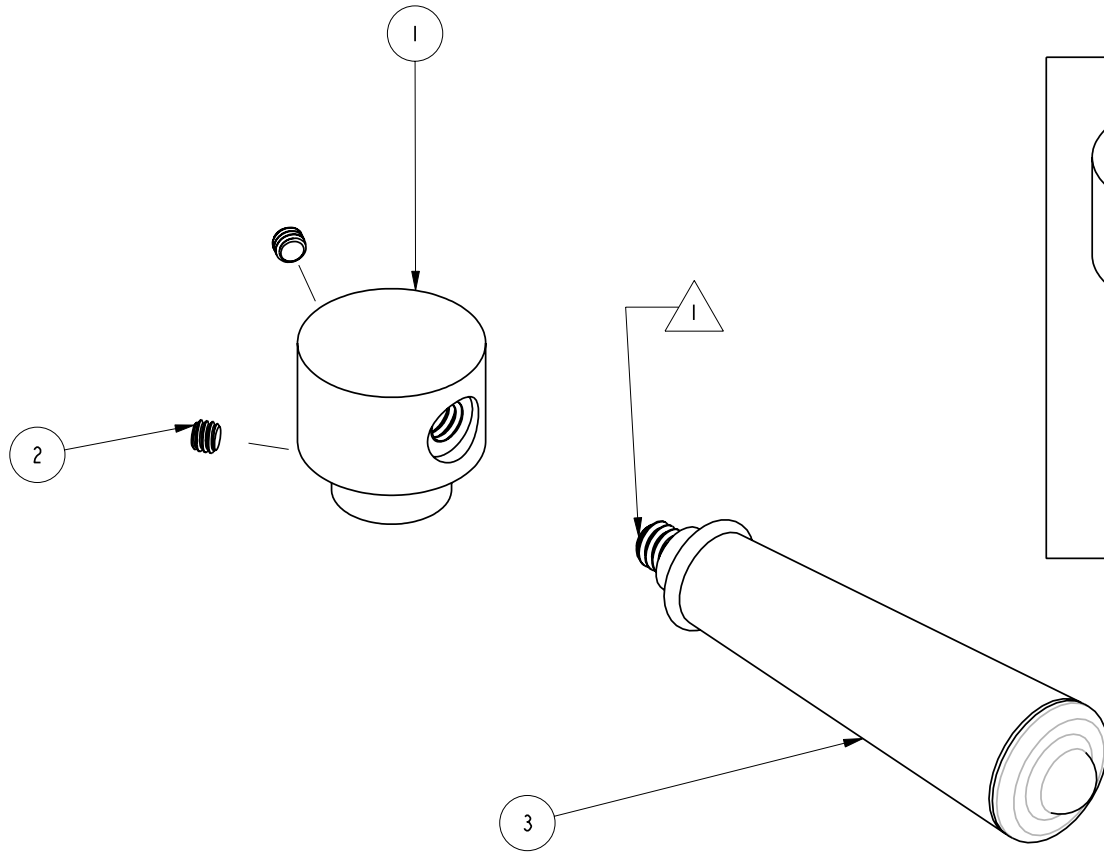

COPYRIGHT 2005 BRASSTECH, INC. THESE DRAWINGS AND THE DESIGNS DEPICTED HEREIN ARE THE PROPRIETARY PROPERTY OF BRASSTECH. ANY USE OR REPRODUCTION IS SUBJECT TO THE EXPRESS APPROVAL OF BRASSTECH. UNAUTHORIZED USE IS STRICTLY PROHIBITED. ALL RIGHTS RESERVED.

BRASSTECH
INCORPORATED
2001 E. CARNEGIE AVE.
SANTA ANA, CA 92705
(949) 417-5207

TAPERED LEVER HNDL ASM

ASSY. NO.	2-279			A	EO-0741	7/7/06
SCALE 1.000	REF. -	SHEET 1 OF 1	REV	REV DESC	DATE	-
						RELEASE 9/17/01