

NOTES:

- (NI) 1. FIT / FORM / FUNCTION SHALL FOLLOW PS-E.008.
- 2. TRIM 3/8" OF SPLIT RING AND PLACE BETWEEN SPOUT AND BODY.

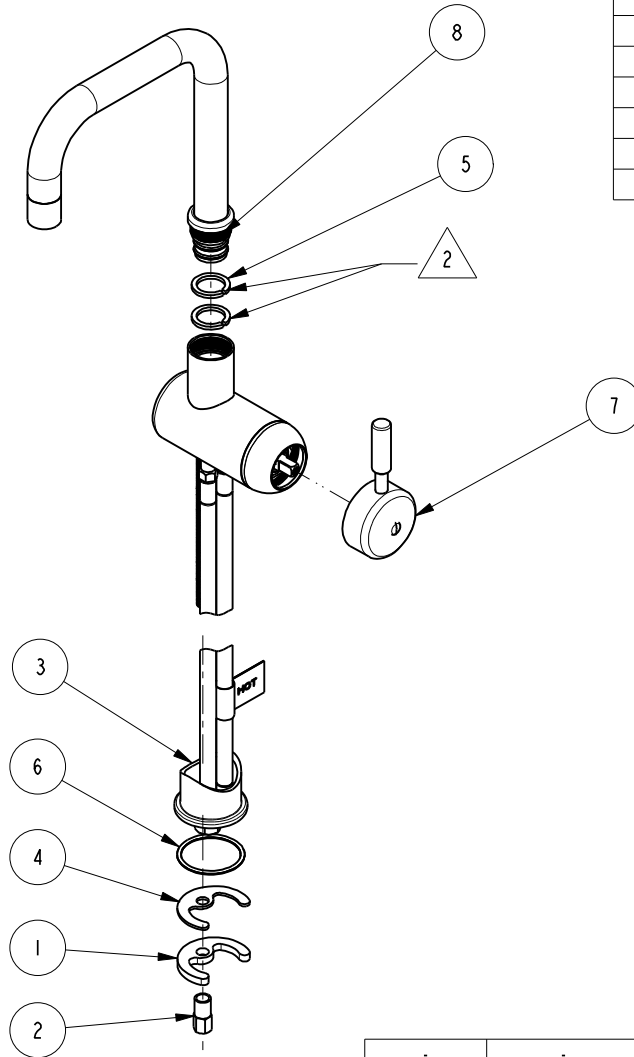

BILL OF MATERIAL (CURRENT LEVEL)

ITEM	PT/ASSY	DESCRIPTION	TYPE	QTY.
1	10514	MOUNTING CRESCENT	PART	1
2	10516	MOUNTING NUT	PART	1
3	10652	BODY COLLAR	PART	1
4	91063	MOUNTING CRESCENT GASKET	PART	1
5	91111	SPLIT RING 3/4 X 1 NYLON	PART	2
6	91763	O-RING, #2- 129, EP, 50 DURO - GREY	PART	1
7	3-205	BODY, CARTRIDGE, HANDLE ASM.	ASSEMBLY	1
8	3-207	BAR SPOUT ASSEMBLY SQUARE	ASSEMBLY	1

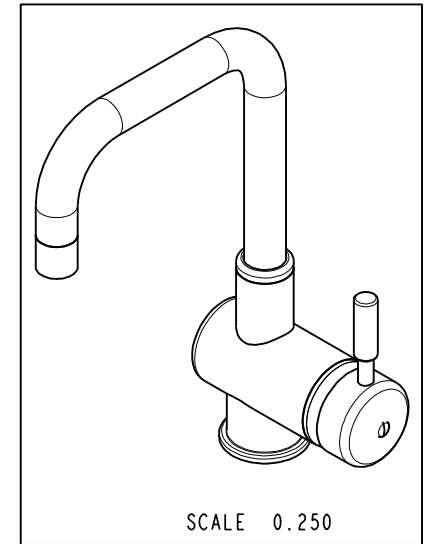

ZONE	REV	DESCRIPTION	DATE	APPROVED
-	C	EN-3722	02/08/19	C.G.
-	B	EN-2643	01/15/16	J.M
-	A	EN-2119	07/24/12	-
-	-	RELEASED	05/23/03	-

COPYRIGHT 2005 BRASSTECH, INC. THESE DRAWINGS AND THE DESIGNS DEPICTED HEREIN ARE THE PROPRIETARY PROPERTY OF BRASSTECH. ANY USE OR REPRODUCTION IS SUBJECT TO THE EXPRESS APPROVAL OF BRASSTECH. UNAUTHORIZED USE IS STRICTLY PROHIBITED. ALL RIGHTS RESERVED.

TESTING	-	-	-
ASSEMBLY	-	-	-
PLATING	-	-	-
POLISHING	-	NEXT ASSY	USED ON
MACHINING	-	APPLICATION	
TOOLING FIXTURE #	REMOVE ALL BURRS AND SHARP EDGES		

UNITS ARE: INCHES [MM]		
TOLERANCES ARE:		
FRACTIONS	DECIMALS	ANGLES
±1/16"	.X ±.1 [2.5]	±1°
	.XX ±.06 [1.5]	
(X.XXX) DENOTES CRITICAL DIMS.		
ALL THREADS ARE CRITICAL		
DRAWN	JINSON	02/08/19
CHECKED	C.G.	02/08/19
APPROVED	C.G.	02/08/19

BRASSTECH 2001 CARNEGIE AVE. SANTA ANA, CA 92705 (949) 417-5207
INCORPORATED

SQUARE SINGLE HOLE BAR FAUCET

DWG NO. **2007** REV **C**

SCALE 0.200 REF. - SHEET 1 OF 2

4

3

2

1

D

D

C

C

B

B

A

A

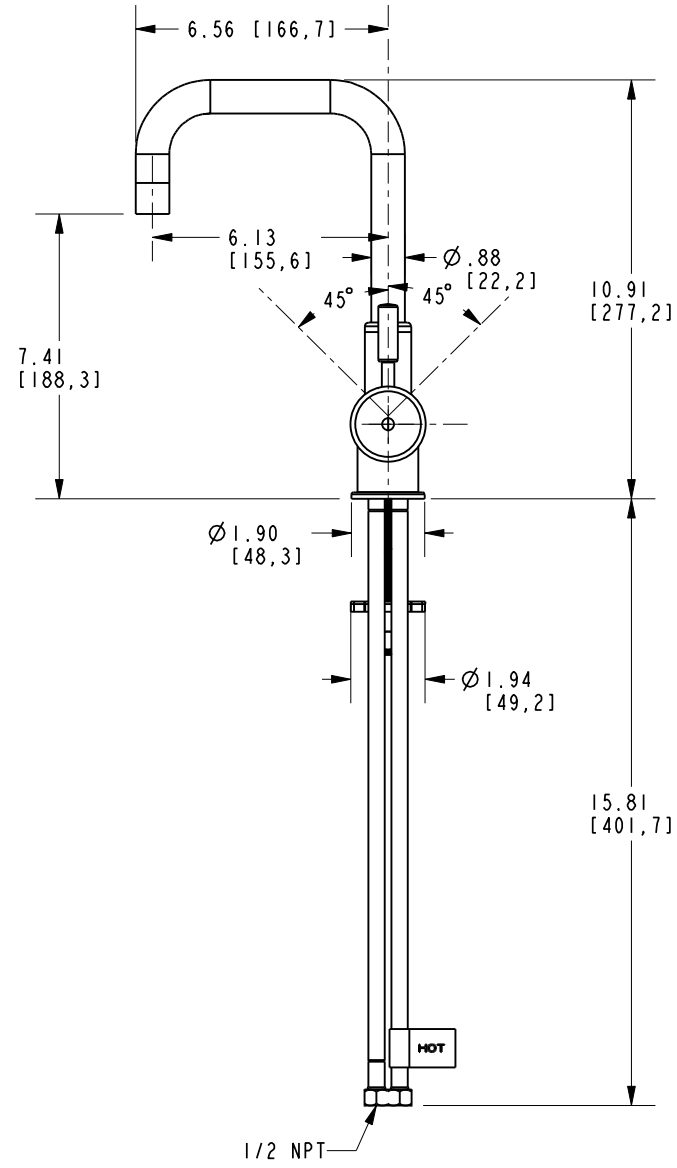
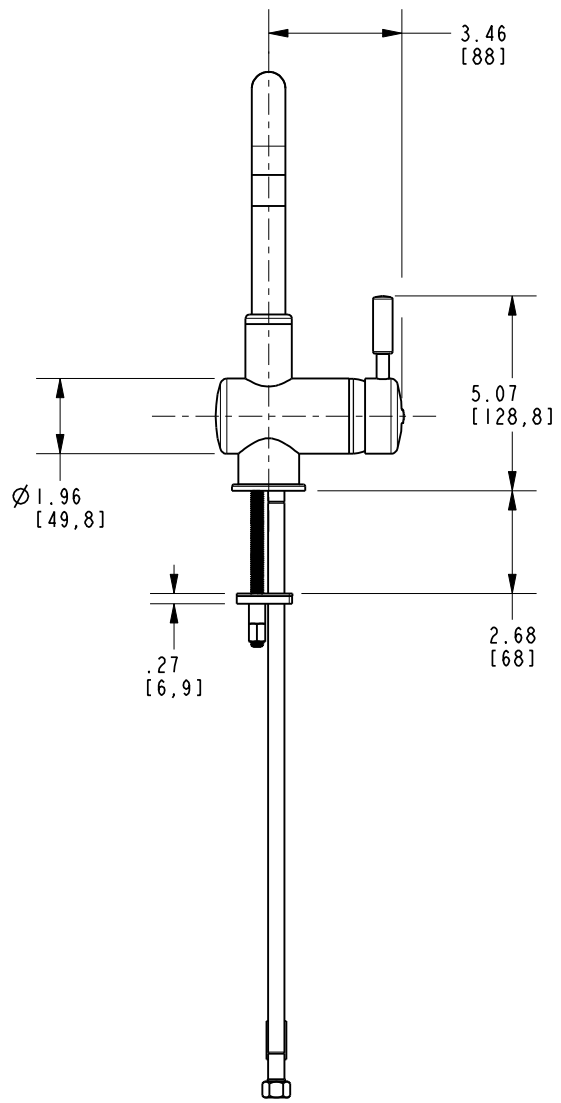

BRASSTECH		2001 E. CARNEGIE AVE. SANTA ANA, CA 92705 (949) 417-5207	
DWG NO.	2007	REV	C
SCALE	0.200	REF.	-
SHEET 2		OF 2	

4

3

2

1