

## ⚠ WARNING

DISCONNECT POWER BEFORE RELAMPING OR WIRING THE FIXTURE  
READ ALL INSTRUCTIONS COMPLETELY BEFORE STARTING INSTALLATION.

## ⚠ CAUTION

- TO AVOID THE RISK OF FIRE OR SHOCK, FIXTURE MUST BE INSTALLED IN COMPLIANCE WITH ALL APPLICABLE NATIONAL AND LOCAL ELECTRICAL/BUILDING CODES.
- INSTALLATION AND MAINTENANCE OF THIS UNIT REQUIRES AN ELECTRICIAN OR CERTIFIED FACTORY TRAINED TECHNICIAN.
- If an existing fixture is being replaced, remove it and note to which of the wires in the outlet box the fixture was attached. DO NOT SEPARATE ANY OTHER WIRES THAT MAY BE IN THE BOX. DO NOT DAMAGE THE INSULATION OF OLDER WIRING. In regular circumstances the BLACK wire will be the "Hot" lead and the WHITE wire will be the "Neutral" or "Common" lead A GREEN or BARE COPPER wire is the "Ground". In older buildings it is always good practice to reconfirm the polarity of the wiring.

## NOTICE

- The important safeguards and instructions outlined on this sheet cannot cover all possible conditions and situations that may occur. It must be understood that common sense, caution and care factors that cannot be built into any product. Caution and care must be supplied by the person(s) installing, operating and caring of this lighting fixture.
- This fixture is design to be mounted on a correctly installed standard round or octagon box or a through wiring box with a plaster frame. The box must be securely mounted to the structure of the building. The crossbar and hardware supplied should be used. Directly mounting the fixture to the outlet box may make it impossible to correctly align the fixture.

### FIXTURE PREPARATION

1. Remove the fixture and parts bag(s) from the carton.

#### NOTICE:

Before discarding the carton,  
double check to make certain that all parts are found.

### FIXTURE INSTALLATION

1. Insert the aircraft cable into the cable grip post of the canopy. Push the tab down on the cable grip and feed the aircraft cable. Repeat this step until you have insert all aircraft cable. (Refer Figure-1)
  2. Insert the SVT wire to bushing. (Refer Figure-1)
- NOTE:**  
Insure the height of aircraft cable and SVT wire would be sufficient as you hang the fixture
3. To change the drop height based on your desired height, push the tab down on the grip post either pull or push the aircraft cable. Repeat this to all aircraft cable until the fixture is level and with the desired height. (Refer to Figure-3)
  4. Adjust the SVT wire base on the desired height. Pull/push the SVT wire to the bushing and leave 8" lead and ground wire above the canopy and cut the excess wire. (Refer to Figure-3)

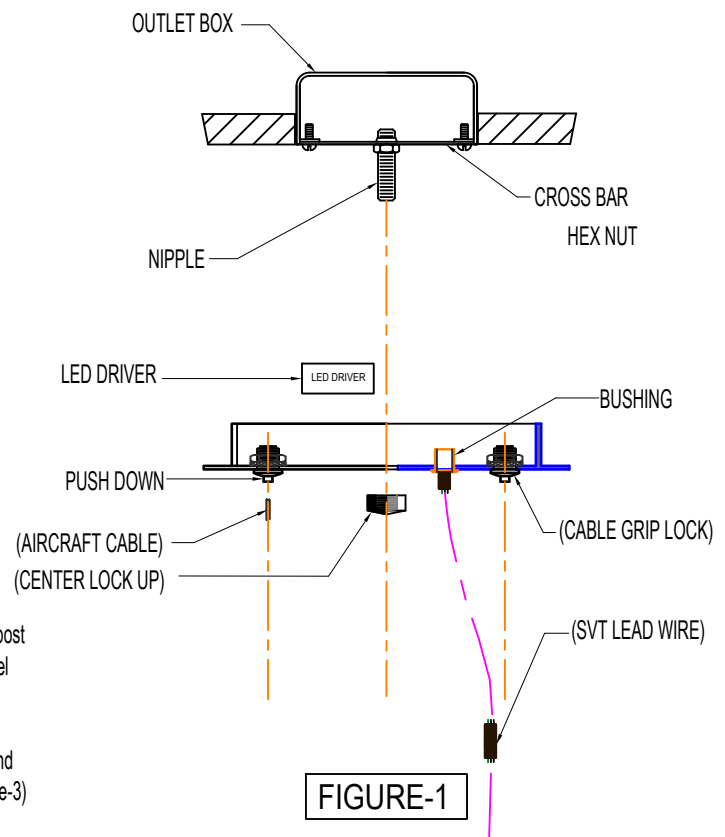
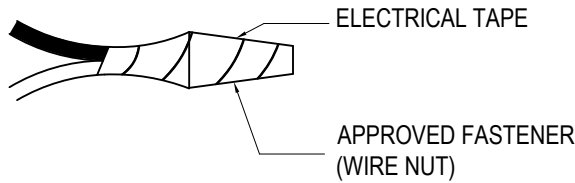

FIGURE-1

5. Place the led driver on the top of canopy and start wiring the fixture. Connect by fastening the black wire (+) coming from the fixture into the led driver where as red wire indicated. (Refer to the figure 2)

6. fasten the white wire (-) coming from the fixture into the led driver where as blue wire



**WARNING**  
DO NOT EXCEED RECOMMENDED WATTAGE!

**NOTICE:**  
Must use a incandescent dimmer with LED's on this fixture.  
\*Lutron Maestro dimmer not compatible.

**WARNING**  
Never fasten the ground wire to the black or "hot" wire! Failure to follow this instruction could result in serious injury or death!

**WARNING**  
Make sure that there is no exposed wire or strands that could cause a dangerous short circuit!

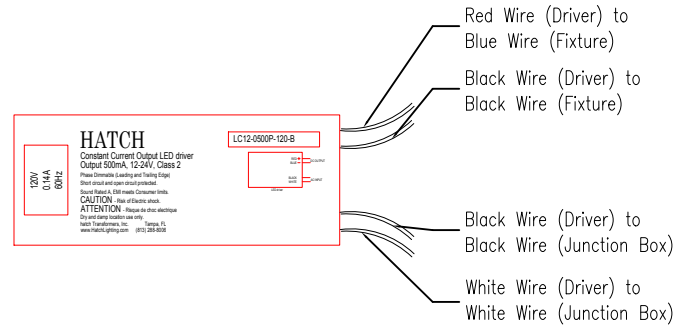

7. Attach the mounting bracket to the outlet box using the mounting screws. (Refer Figure-1).

8. Fasten the ground wire to the green or bare copper wire in the outlet box (if outlet box is plastic) or to the green screw on the mounting bracket.

9. Fasten the white wire from the junction box into the led driver where as white wire indicated (AC) (Refer Figure-2)

10. Fasten the black wire from the junction box into the led driver where as black wire indicated (AC). (Refer Figure-2)

SEE ALSO DRIVER COLOR CODING  
LED LAMP TO LED DRIVER  
WIRE CONNECTION DETAILS

FIGURE-2

**NOTE:**  
Need another person that will hold the fixture during installation.

11. Thread the hex nut onto the nipple and the nipple into the mounting bracket . Place the canopy over the nipple and against the ceiling. Adjust the nipple so that 1/2" of threads extend beyond the canopy. (Refer to Figure 1)

12. Using the center lock up, loosely fasten the fixture to the outlet box. Adjust the orientation of the fixture. Refer to step 3 and 4 and Figure 3.

13. Once the required orientation met, tighten the center lock. Refer to Figure 1 & 3.

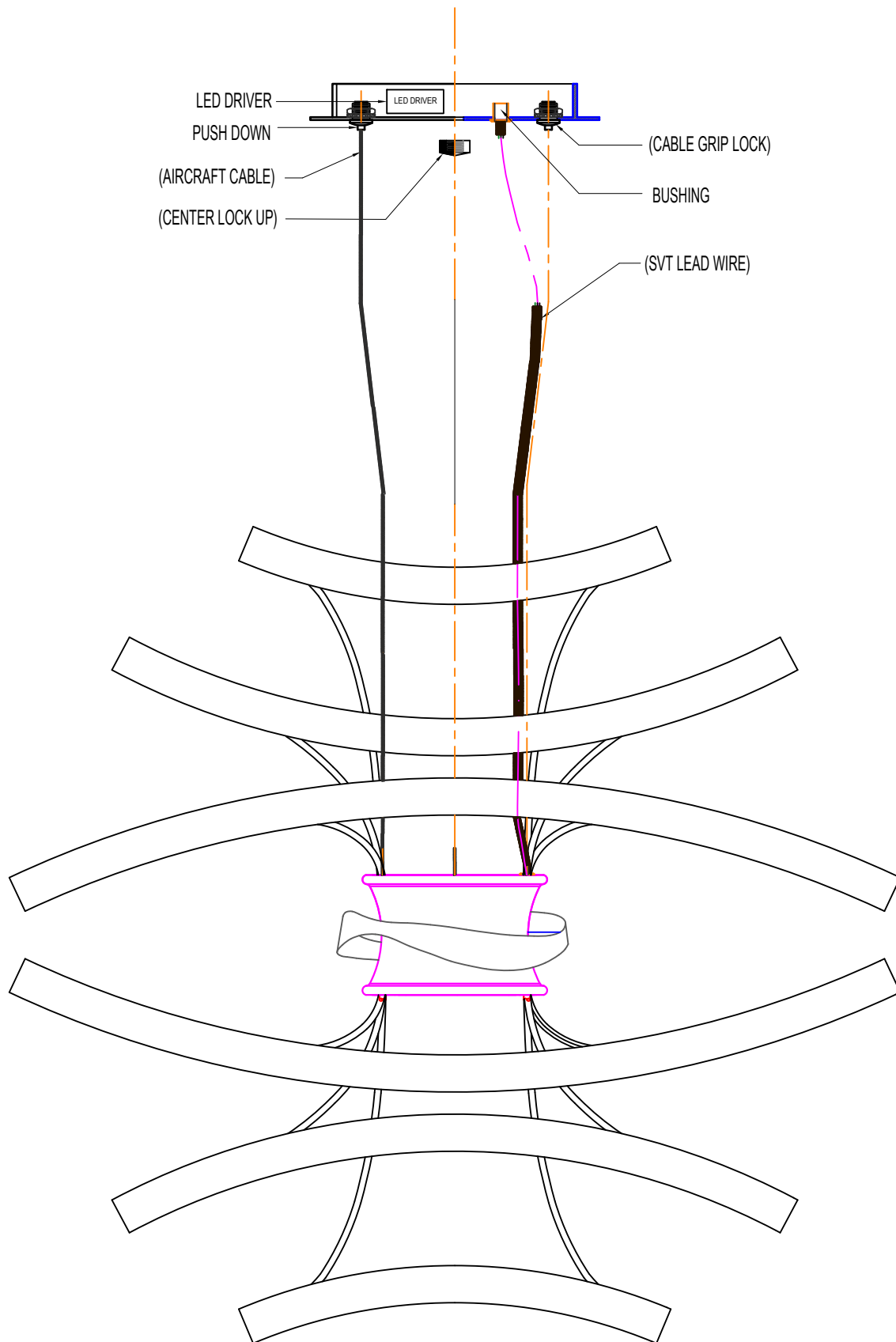

FIGURE-3

## FIXTURE REASSEMBLY

**NOTE:**

Fixture should be reassemble prior to installation.

1. Identify Fixture A, Remove the protective cover on the LED Light on the bottom portion.
2. Identify Fixture B, place the glass on the top of fixture. Refer to Figure-3.
3. Attach Fixture B to Fixture A using the provided bolt. Use the appropriate tool in tightening the bolt. Refer to Figure 3.

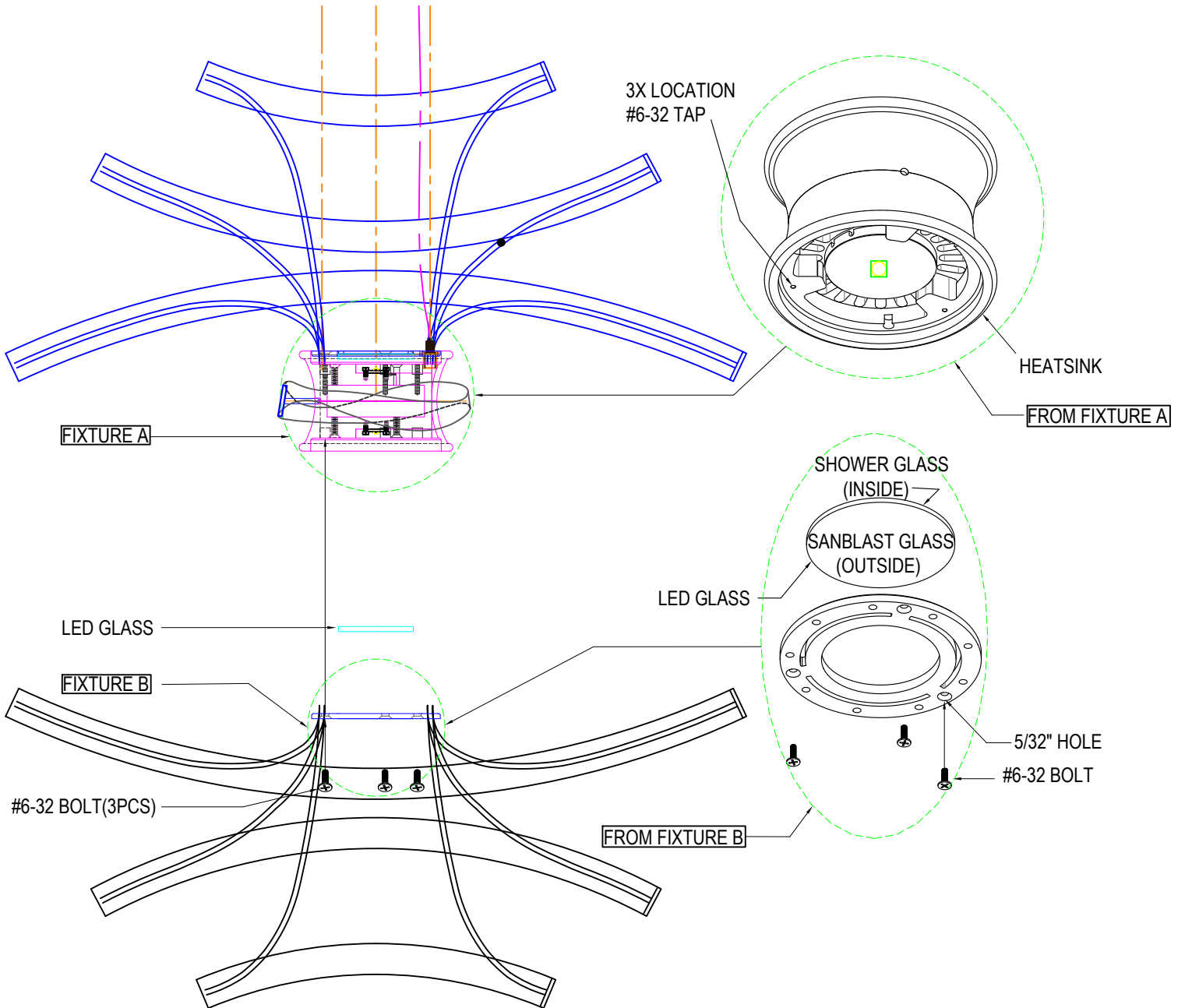

FIGURE- 4

14. Restore power to circuit at breaker or fuse box.