

NOTES:

(N2) 1. FIT / FORM / FUNCTION SHALL FOLLOW PS-E.008.

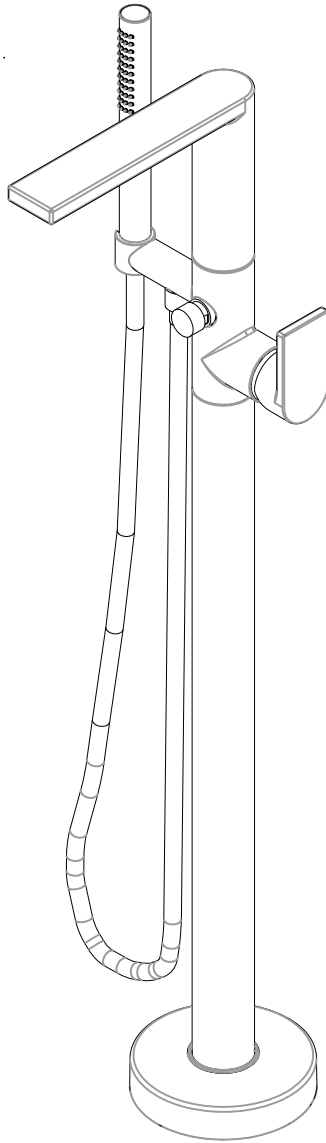

BILL OF MATERIAL (CURRENT LEVEL)

ITEM	PT/ASSY	DESCRIPTION	TYPE	QTY.
1	12187	BODY	PART	1
2	20-233	SPOUT ASM	ASSEMBLY	1
3	92308	SCRW, M5 X 5 SKT HD CUP PT SS	PART	2
4	10159	HEX KEY, 3/32 ALLOY STEEL	PART	1
5	20-260	DIVERTER ASM	ASSEMBLY	1
6	20-259	DIVERTER ASM	ASSEMBLY	1
7	12191	DIVERTER BUTTON	PART	1
8	12175	HAND SHWR HOLDER	PART	1
9	92821	SCREW	PART	1
10	1-292	CARTRIDGE	ASSEMBLY	1
11	92035	SCRW, M4 X .7 X 10 PHL FLT HD SS	PART	1
12	12180	RETAINER CART. NUT	PART	1
13	12181	CAP, CARTRIDGE	PART	1
14	12197	HANDLE	PART	1
15	12195	HOLE COVER	PART	1
16	20-310	BODY ASM	ASSEMBLY	1
17	3-460	BASE COVER ASM	ASSEMBLY	1
18	283-101	ROUND WAND HANDSHOWER	ASSEMBLY	1
19	12184	WATER SUPPLY HOSE	ASSEMBLY	2
20	12257	1/2 X 3/4 NPSM THD ADAPTER	PART	2
21	284	SHOWER HOSE	PART	1
22	91017	O-RING, #2- 012, EPDM, 65-75 DURO, NSF	BART	1
23	12189	ADAPTER	PART	1
24	92070	SCRW, #14 X 2 SLT FLT HD SS	PART	3
25	91368	WALL ANCHOR PLASTIC, 12-1/4	PART	3
26	98044	LABEL - HOT	PART	1

C.GAYOSSO
08/01/19

ZONE	REV	DESCRIPTION	DATE	APPROVED
A	EN-3409	6/26/19	J. A.	
-	EN-3015	9/15/17	J. A.	

COPYRIGHT 2005 BRASSTECH, INC. THESE DRAWINGS AND THE DESIGNS DEPICTED HEREIN ARE THE PROPRIETARY PROPERTY OF BRASSTECH. ANY USE OR REPRODUCTION IS SUBJECT TO THE EXPRESS APPROVAL OF BRASSTECH. UNAUTHORIZED USE IS STRICTLY PROHIBITED. ALL RIGHTS RESERVED.

TESTING	-	-	-
ASSEMBLY	-	-	-
PLATING	-	-	-
POLISHING	-	NEXT ASSY	USED ON
MACHINING	-	APPLICATION	
TOOLING FIXTURE #		REMOVE ALL BURRS AND SHARP EDGES	

UNITS ARE: INCHES [MM]		
TOLERANCES ARE:		
FRACTIONS DECIMALS	ANGLES	
±1/16"	±P	
.X ±.1 [2,5]		
.XX ±.06 [1,5]		
(X.XXX) DENOTES CRITICAL DIMS.		
ALL THREADS ARE CRITICAL		
DRAWN	H. LE	12/01/16
CHECKED	V. VU	12/01/16
APPROVED	V. VU	12/01/116

BRASSTECH 2001 CARNEGIE AVE.
INCORPORATED SANTA ANA, CA 92705
(949) 417-5207

TUB FILLER, FREE STANDING

DWG NO. 2560-4261 REV A

SCALE .100 REF. SHEET | OF 4

NOTES:

- 2. APPLY LOCTITE 680
- 3. TORQUE TO 7.5-8.5 LB-FT.
- 4. APPLY LOCTITE 242, IF SCREW DOES NOT HAVE BYLON PATCH.
- 5. TORQUE TO 18-20 LB-IN.
- 6. PLACE THESE ITEMS IN SEPARATE PLASTIC BAGS.
- 7. APPLY A THIN COAT OF SILICON GREASE
- 8. FOR PURCHASED FINISHES SEE PART NUMBER 3-459/ZZ

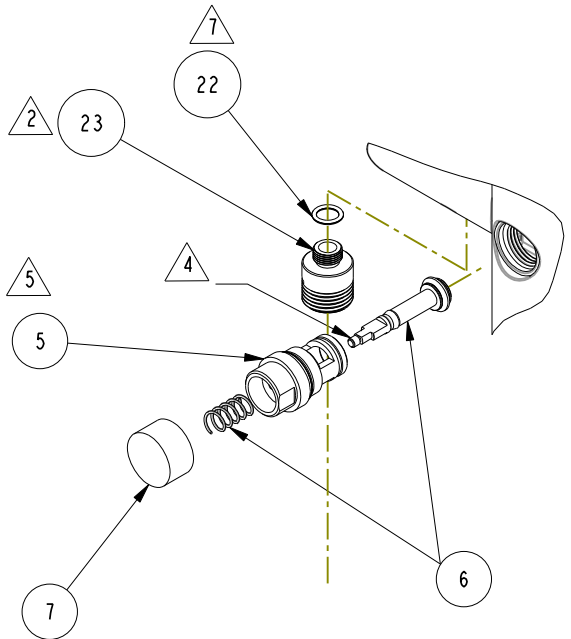
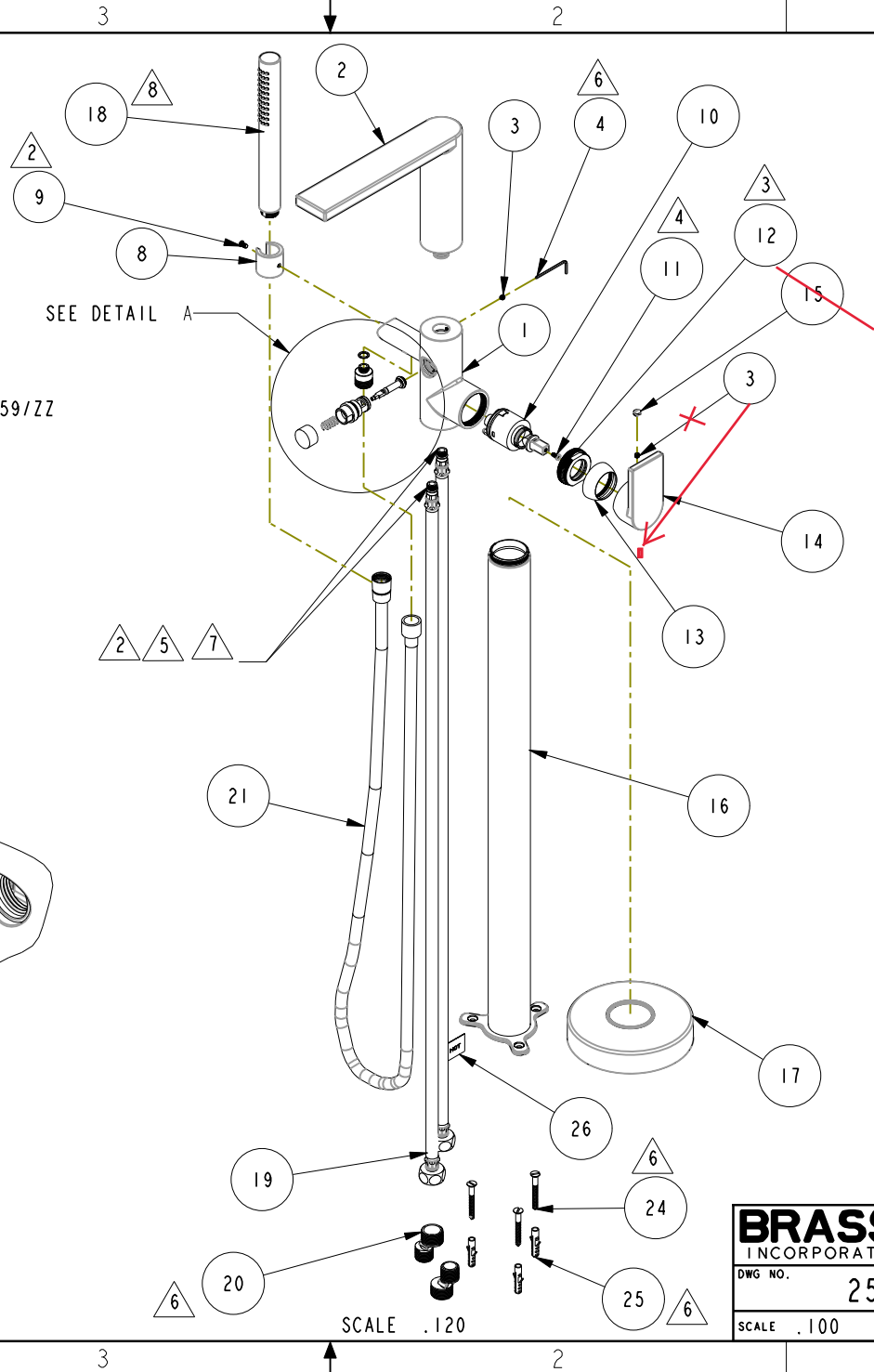

DETAIL A
SCALE .325

SCALE .120

BRASSTECH		2001 E. CARNEGIE AVE. SANTA ANA, CA 92705 (949) 417-5207	
DWG NO.	2560-4261	REV	A
SCALE .100	REF.	SHEET 2	OF 4

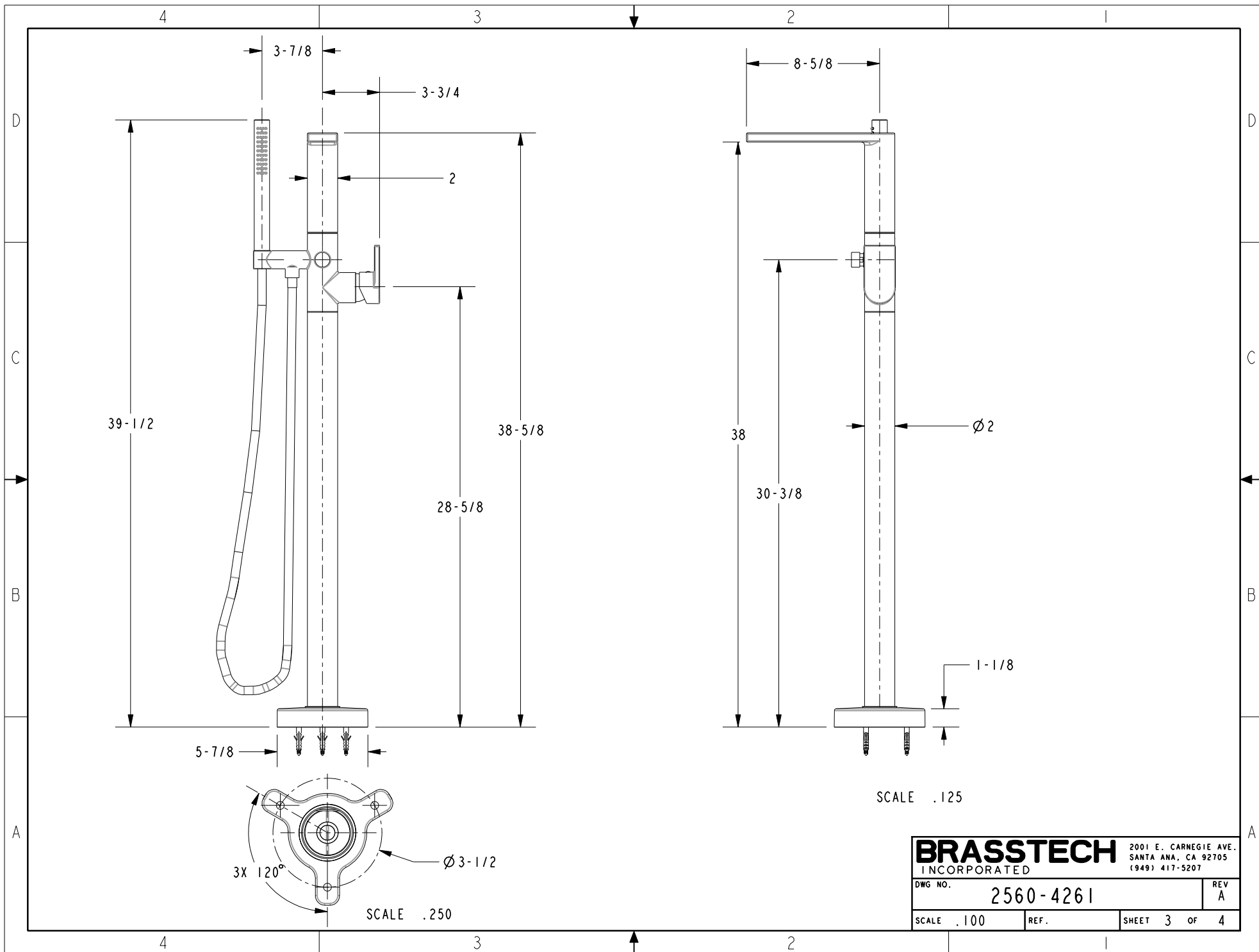

39-1/2

3-7/8

3-3/4

2

38-5/8

28-5/8

5-7/8

3X 120°

Ø 3-1/2

SCALE .250

8-5/8

38

30-3/8

1-1/8

Ø 2

SCALE .125

BRASSTECH		2001 E. CARNEGIE AVE. SANTA ANA, CA 92705 (949) 417-5207	
DWG NO.	2560-4261	REV	A
SCALE .100	REF.	SHEET 3	OF 4

NOTES:

1. \longleftrightarrow INDICATES STROKE DIRECTION FOR SATIN FINISHES ONLY.

2. SAND BLAST THIS SURFACE.

3. APPLY APPLICABLE CLEAT COMPLIANCE LABEL ON THE BACK SIDE OF THE HAND SHOWER.

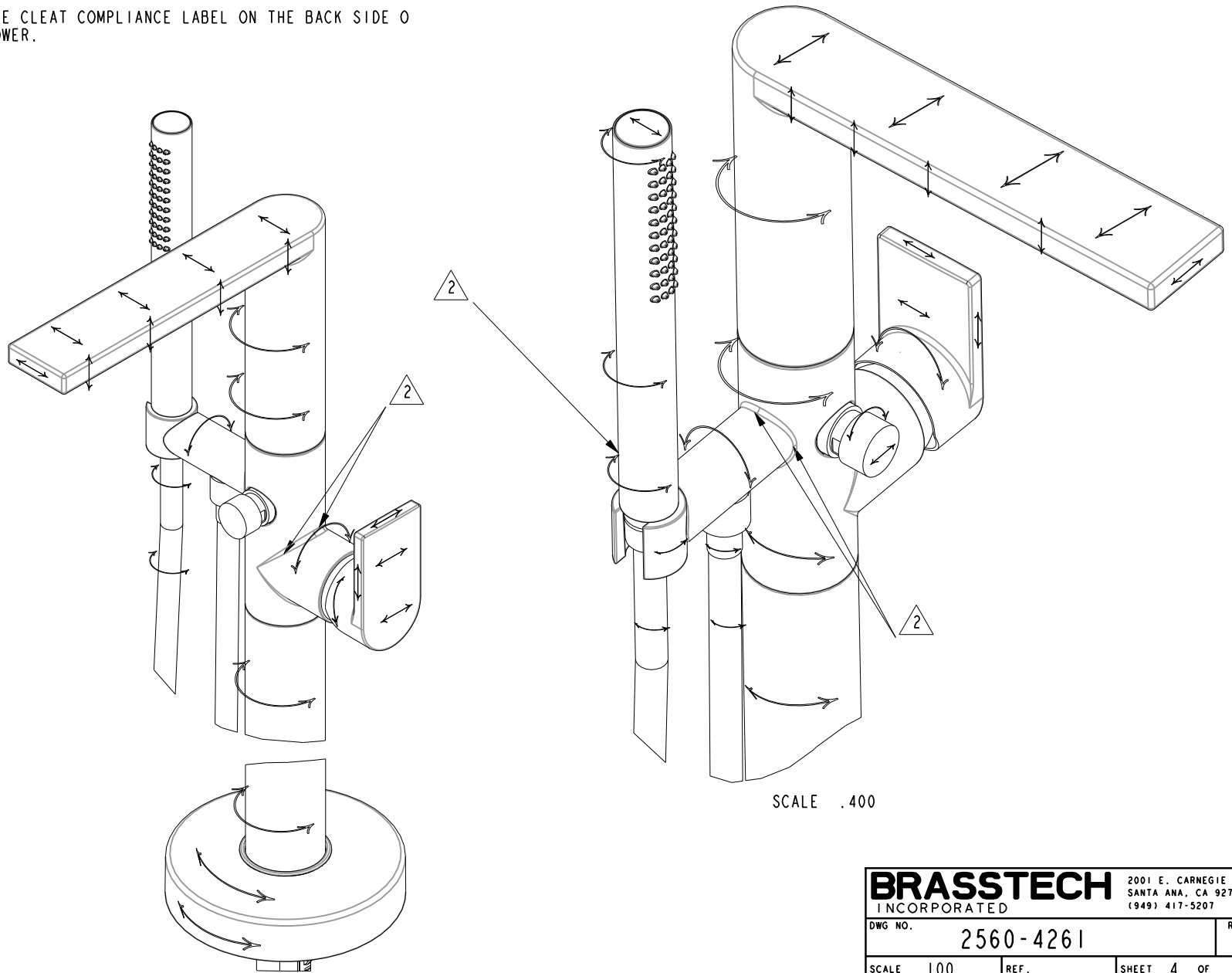

SCALE .400

BRASSTECH		2001 E. CARNEGIE AVE. SANTA ANA, CA 92705 (949) 417-5207	
DWG NO.	2560-4261	REV	A
SCALE .100	REF.	SHEET 4	OF 4