

NOTES:

- (N1) 1. FIT / FORM / FUNCTION SHALL FOLLOW PS-E.008.
- 2 APPLY LOCTITE 680.
- 3 CUT AND SHORTEN O-RING BY .13" TO .20" IN LENGTH BEFORE INSTALLING.
- 4 SLIT O-RING BEFORE INSTALLING.
- 5 APPLY LOCTITE 242.
- (N6) 6. WATER TEST WHOLE UNIT.
- 7 BAG 5-007 IN A SEPARATE BAG.
- 8 INSTALLATION TORQUE: 8-14 LB-FT.
- 9 APPLY LIGHT FILM OF DOW CORNING 111 SILICONE COMPOUND.

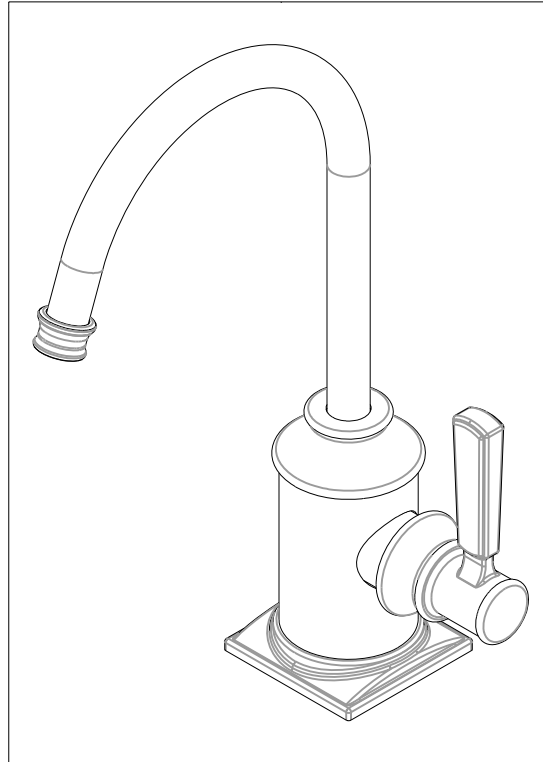

BILL OF MATERIAL (CURRENT LEVEL)

ITEM	PT/ASSY	DESCRIPTION	TYPE	QTY.
1	1-134	CARTR 3/8 HOT 1/4 TR	PART	1
2	5-007	1/4 COMP KIT	ASSEMBLY	1
3	20-248	BASE RING ASM	ASSEMBLY	1
4	20-288	HANDLE HUB ASM	ASSEMBLY	1
5	10514	MOUNTING CRESCENT	PART	1
6	10516	MOUNTING NUT	PART	1
7	10661	MOUNTING STUD	PART	1
8	11733	SHELL, SPOUT, WATER DISP	PART	1
9	12512	BONNET	PART	1
10	12703	COLLAR	PART	1
11	12750	ADAPTER	PART	1
12	50713	SPOUT, WATER DISP. (TRAD.)	PART	1
13	50714	WATER DISP. CAR.T HOLDER	PART	1
14	50715	WATER DISP BODY (CONT.)	PART	1
15	50717	WATER DISP SPOUT RETAINER	PART	1
16	50760	NIPPLE WATER DISP	PART	1
17	91017	O-RING, #2- 012, EPDM, 65-75 DURO, NSF 61	PART	2
18	91023	O-RING, #2- 019, EPDM, 65-75 DURO, NSF 61	PART	1
19	91063	MOUNTING CRESCENT GASKET	PART	1
20	91382	O-RING, #2- 012, TEFLON,	PART	1
21	91383	O-RING, #2- 014, TEFLON, NSF 61	PART	1
22	91424	WSHR, .81 ID X .93 OD X .045 THK, FLT, PLST	PART	1
23	92862	SCRW, M4 X 18 SKT FLT HD SS	PART	1

TESTING	-	-	-
ASSEMBLY	-	-	-
PLATING	-	-	-
POLISHING	-	NEXT ASSY	USED ON
MACHINING	-	APPLICATION	
TOOLING FIXTURE #		REMOVE ALL BURRS AND SHARP EDGES	

UNITS ARE: INCHES [MM]
 TOLERANCES ARE:
 FRACTIONS DECIMALS ANGLES
 $\pm 1/16"$.X $\pm .1$ (2.5) $\pm 1^\circ$
 .XX $\pm .06$ (1.5)
 (X.XXX) DENOTES CRITICAL DIMS.
 ALL THREADS ARE CRITICAL
 DRAWN JINSON 08/29/18
 CHECKED J.M. 08/29/18
 APPROVED J.M. 08/29/18

BRASSTECH 2001 CARNEGIE AVE.
 INCORPORATED SANTA ANA, CA 92705
 (949) 417-5207

WATER DISPENSER - COLD

DWG NO. **3170-5623** REV B

SCALE .450 REF. - SHEET 1 OF 3

ZONE	REV	DESCRIPTION	DATE	APPROVED
-	B	EN-3941	08/28/19	C.G.
-	A	EN-3693	08/29/18	J.M.
-	-	EN-3076	06/08/17	J.M.

COPYRIGHT 2005 BRASSTECH, INC.
 THESE DRAWINGS AND THE DESIGNS
 DEPICTED HEREIN ARE THE PROPRIETARY
 PROPERTY OF BRASSTECH. ANY USE
 OR REPRODUCTION IS SUBJECT TO
 THE EXPRESS APPROVAL OF BRASSTECH.
 UNAUTHORIZED USE IS STRICTLY
 PROHIBITED. ALL RIGHTS RESERVED.

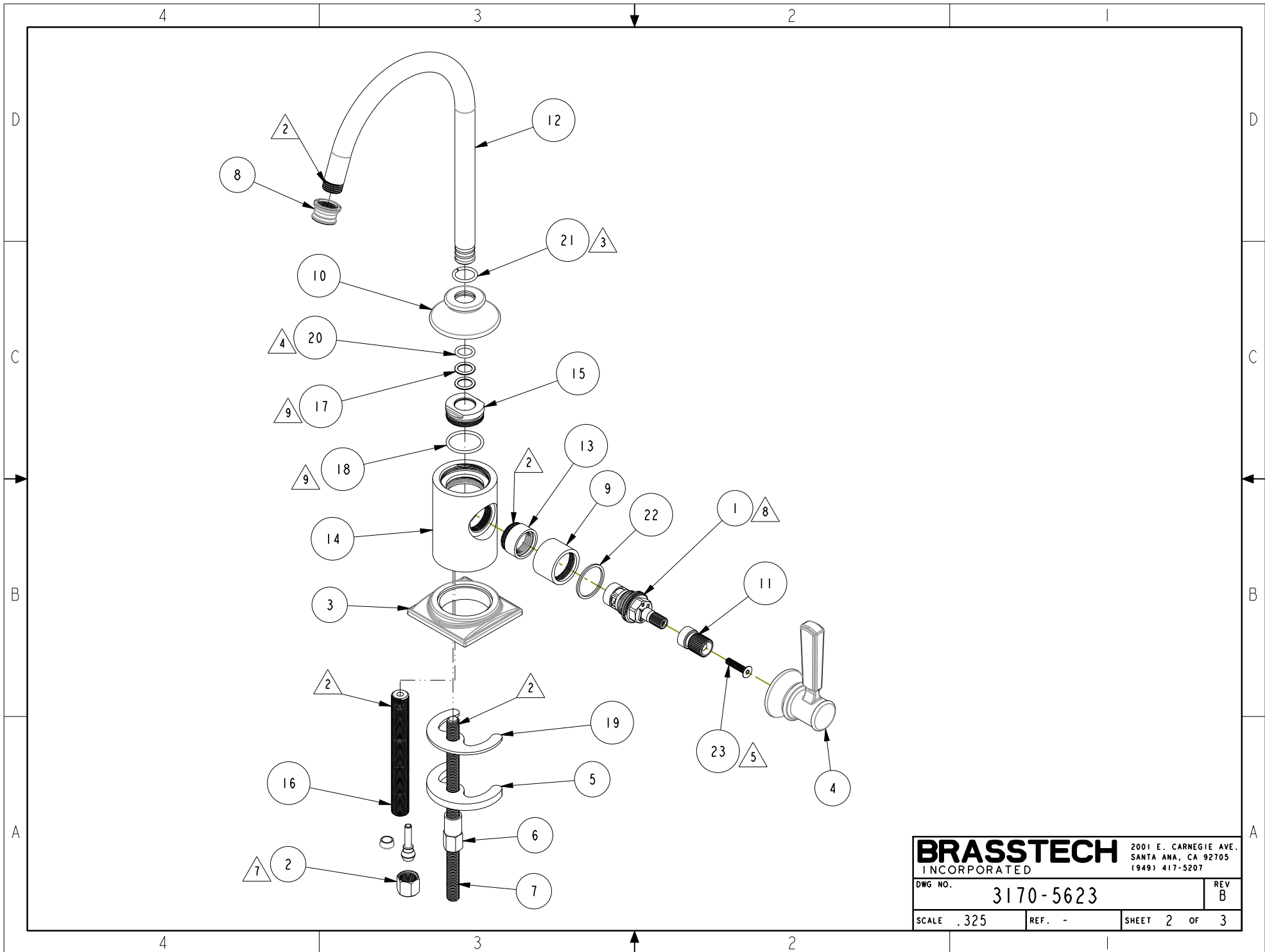

BRASSTECH		2001 E. CARNEGIE AVE. SANTA ANA, CA 92705 (949) 417-5207	
INCORPORATED			
DWG NO.	3170-5623		REV B
SCALE .325	REF. -	SHEET 2 OF 3	

