

<b>BRASSTECH</b>		2001 E. CARNEGIE AVE.	
INCORPORATED		SANTA ANA, CA 92705	
DWG NO. 3200-5113		REV B	
SCALE .175	REF. -	SHEET 2 OF 3	

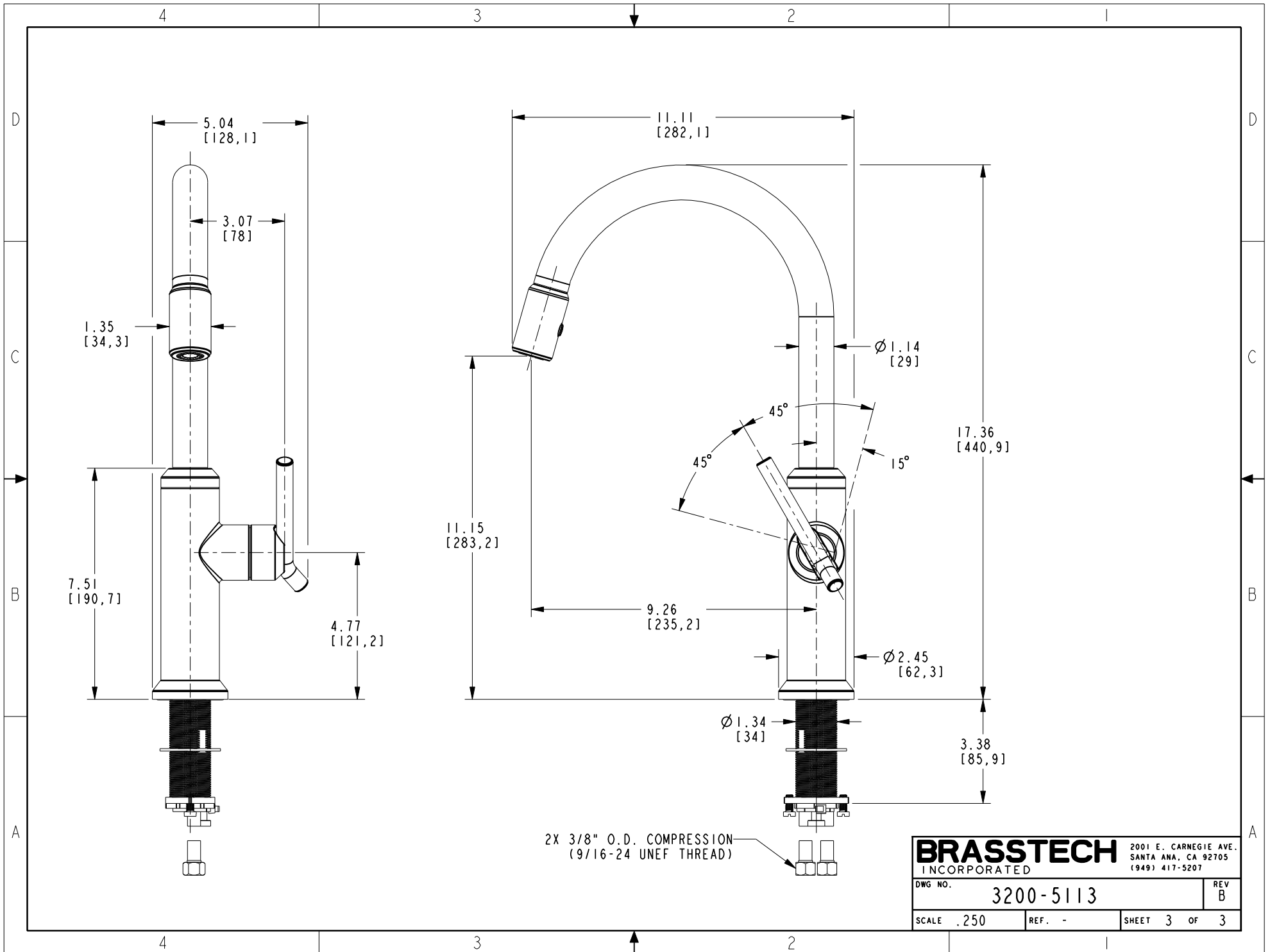

2X 3/8" O.D. COMPRESSION  
(9/16-24 UNEF THREAD)

<b>BRASSTECH</b> INCORPORATED		2001 E. CARNEGIE AVE. SANTA ANA, CA 92705 (949) 417-5207	
DWG NO.	3200-5113	REV	B
SCALE	.250	REF.	-
		SHEET	3 OF 3