

NOTES:

- (NI) 1. FIT / FORM / FUNCTION SHALL FOLLOW PS-E.008.
- 2. PUT THESE ITEMS IN SEPARATE PLASTIC BAGS.
- 3. TORQUE TO 7.5-8.5 LB-FT.
- 4. APPLY LIGHT FILM OF DOW CORNING 111 SILICONE COMPOUND TO ALL O-RINGS PRIOR TO INSTALLATION.
- 5. APPLY LOCTITE 242, IF SCREW DOES NOT HAVE NYLON PATCH.
- 6. APPLY LOCTITE 680.

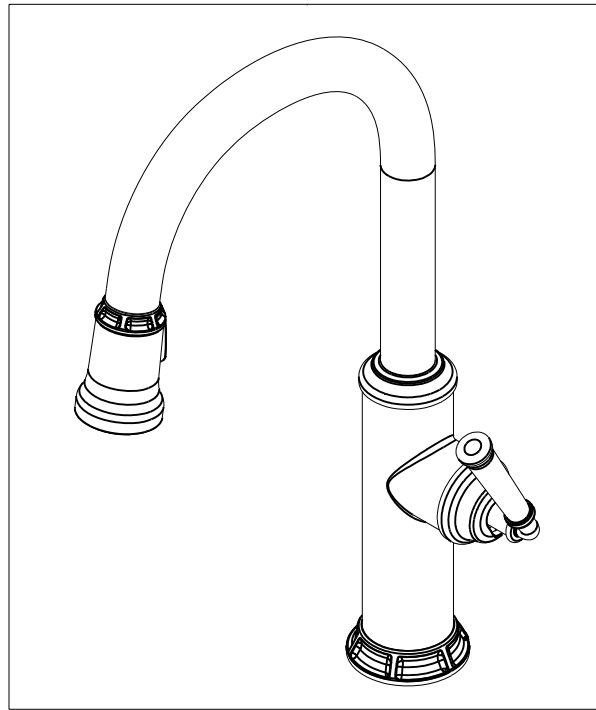

BILL OF MATERIAL (CURRENT LEVEL)

ITEM	PT/ASSY	DESCRIPTION	TYPE	QTY.
1	20-211	BASE RING ASM	ASSEMBLY	1
2	20-278	MAIN BODY ASM, TAFT	ASSEMBLY	1
3	12622	COLLAR	PART	1
4	12637	SPOUT ADAPTER	PART	1
5	91030	O-RING, #2- 115, EPDM, 65-75 DURO, NSF 61	PART	4
6	91712	SLEEVE	PART	1
7	12475	SPOUT, TAFT PULL-DOWN	PART	1
8	91544	MAGNET DOCKING	ASSEMBLY	1
9	11877	HOSE, PULLDOWN, GREY	ASSEMBLY	1
10	3-590	SPRAY HEAD, TAFT	ASSEMBLY	1
11	1-064	SINGLE LEVER CARTRIDGE	PART	1
12	1-266	CART. RETAINER ASM	ASSEMBLY	1
13	12841	HANDLE HUB	PART	1
14	91534	CARTRIDGE STEM INSERT	PART	1
15	11874	HANDLE ADAPTER SCREW	PART	1
16	20-318	HANDLE LEVER ASM	ASSEMBLY	1
17	91255	O-RING, #2- 011, EPDM, 65-75 DURO, NSF-61	PART	2
18	91568	RETAINER CLIP	PART	1
19	1-256	MOUNTING KIT	ASSEMBLY	1
20	91341	ZIP TIE	PART	1
21	98044	LABEL - HOT	PART	1
22	1-286	WEIGHT	ASSEMBLY	1

TESTING	-	-	-
ASSEMBLY	-	-	-
PLATING	-	-	-
POLISHING	-	NEXT ASSY	USED ON
MACHINING	-	APPLICATION	
TOOLING FIXTURE #		REMOVE ALL BURRS AND SHARP EDGES	

BRASSTECH 2001 CARNEGIE AVE.
INCORPORATED SANTA ANA, CA 92705
(949) 417-5207

KITCHEN PULLDOWN

DWG NO. **3210-5103** REV B

SCALE .250 REF. - SHEET 1 OF 3

ZONE	REV	DESCRIPTION	DATE	APPROVED
-	B	EN-3931b	09/24/19	J.M.
-	A	EN-3413b	11/14/17	JM
-	-	EN-3076	02/07/17	JM

COPYRIGHT 2005 BRASSTECH, INC. THESE DRAWINGS AND THE DESIGNS DEPICTED HEREIN ARE THE PROPRIETARY PROPERTY OF BRASSTECH. ANY USE OR REPRODUCTION IS SUBJECT TO THE EXPRESS APPROVAL OF BRASSTECH. UNAUTHORIZED USE IS STRICTLY PROHIBITED. ALL RIGHTS RESERVED.

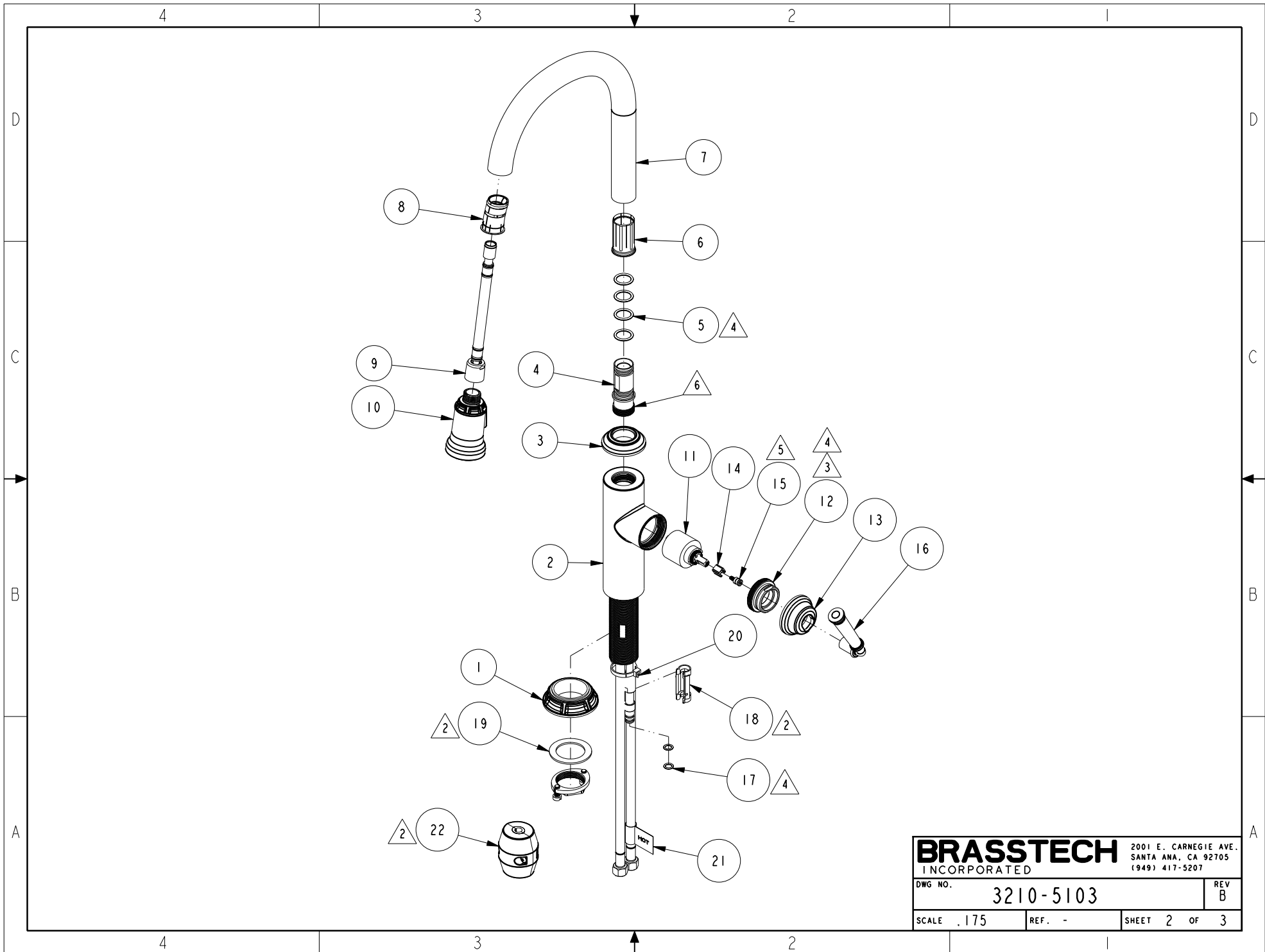

BRASSTECH		2001 E. CARNEGIE AVE.	
INCORPORATED		SANTA ANA, CA 92705	
DWG NO. 3210-5103		REV B	
SCALE .175	REF. -	SHEET 2 OF 3	

