

4

3

2

1

NOTES:

- (N1) 1. FIT / FORM / FUNCTION SHALL FOLLOW PS-E.008.
- 2. APPLY LOCTITE 680.
- 3. SLIT AND SHORTEN O-RING BY .13" TO .20" IN LENGTH BEFORE INSTALLING.
- 4. SLIT O-RING BEFORE INSTALLING.
- 5. INSTALLATION TORQUE: 8 -14 LB-FT.
- (N6) 6. WATER TEST WHOLE UNIT.
- 7. BAG 5-007 IN A SEPARATE BAG.
- 8. APPLY THIN FILM OF DOW CORNING 111.
- 9. APPLY LOCTITE 242.

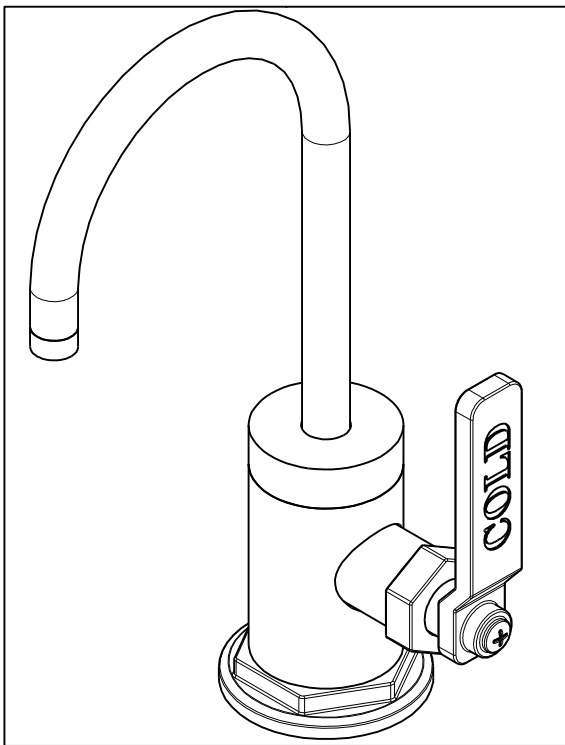

BILL OF MATERIAL (CURRENT LEVEL)

ITEM	PT/ASSY	DESCRIPTION	TYPE	QTY.
1	20-338	ESCUTCHEON ASM	ASSEMBLY	1
2	50715	WATER DISP BODY (CONT.)	PART	1
3	50717	WATER DISP SPOUT RETAINER	PART	1
4	91023	O-RING, #2- 019, EPDM, 65-75 DURO, NSF 61	PART	1
5	5-052	SPOUT ASM	ASSEMBLY	1
6	91382	O-RING, #2- 012, TEFLON,	PART	1
7	91017	O-RING, #2- 012, EPDM, 65-75 DURO, NSF 61	PART	2
8	50716	WATER DISP BODY CAP (CONT.)	PART	1
9	91383	O-RING, #2- 014, TEFLON, NSF 61	PART	1
10	50714	WATER DISP. CAR.T HOLDER	PART	1
11	1-134	CARTR 3/8 HOT 1/4 TR	PART	1
12	12750	ADAPTER	PART	1
13	50760	NIPPLE WATER DISP	PART	1
14	5-007	1/4 COMP KIT	ASSEMBLY	1
15	10661	MOUNTING STUD	PART	1
16	91063	MOUNTING CRESCENT GASKET	PART	1
17	10514	MOUNTING CRESCENT	PART	1
18	10516	MOUNTING NUT	PART	1
19	92862	SCRW, M4 X 18 SKT FLT HD SS	PART	1
20	12926	BONNET DECO	PART	1
21	20-339	HANDLE ASM, COLD	ASSEMBLY	1

D

D

C

C

B

B

A

A

COPYRIGHT 2005 BRASSTECH, INC. THESE DRAWINGS AND THE DESIGNS DEPICTED HEREIN ARE THE PROPRIETARY PROPERTY OF BRASSTECH. ANY USE OR REPRODUCTION IS SUBJECT TO THE EXPRESS APPROVAL OF BRASSTECH. UNAUTHORIZED USE IS STRICTLY PROHIBITED. ALL RIGHTS RESERVED.

UNITS ARE: INCHES [MM]
TOLERANCES ARE:
FRACTIONS DECIMALS ANGLES
±1/16" .X ±.1 [2.5] ±1°
.XX ±.06 [1.5]

(X.XXX) DENOTES CRITICAL DIMS.
ALL THREADS ARE CRITICAL

DRAWN JINSON 09/17/18
CHECKED J.M. 09/17/18
APPROVED J.M. 09/17/18

BRASSTECH 2001 CARNEGIE AVE.
INCORPORATED SANTA ANA, CA 92705
(949) 417-5207

WATER DISPENSER - COLD

DWG NO. 3220-5623 REV -

SCALE .500 REF. - SHEET 1 OF 3

ZONE	REV	DESCRIPTION	DATE	APPROVED
-	-	EN-3443	09/17/18	J.M.

TESTING	ASSEMBLY	PLATING	POLISHING	MACHINING	TOOLING FIXTURE #	APPLICATION
-	-	-	-	-	-	REMOVE ALL BURRS AND SHARP EDGES

4

3

2

1

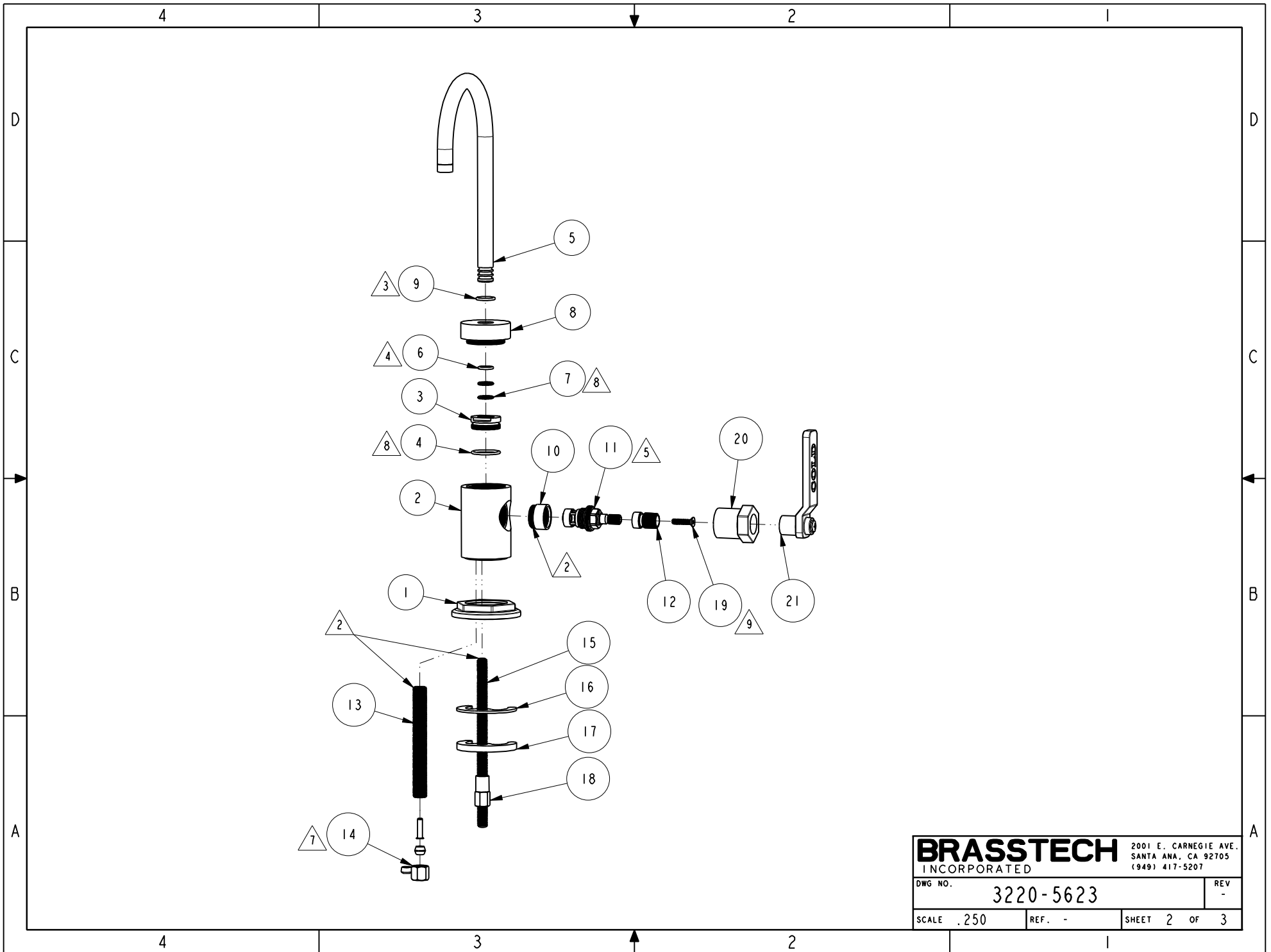

BRASSTECH		2001 E. CARNEGIE AVE.
INCORPORATED		SANTA ANA, CA 92705
		(949) 417-5207
DWG NO.	3220-5623	REV -
SCALE .250	REF. -	SHEET 2 OF 3

