

NOTES:

(N1) 1. FIT / FORM / FUNCTION SHALL FOLLOW PS-E.008.

BILL OF MATERIAL (CURRENT LEVEL)

ITEM	PT/ASSY	DESCRIPTION	TYPE	QTY.
1	12171	ESCUTCHEON, ROMAN TUB	PART	2
2	10523	HEX ESCUTCHEON BONNET	PART	2
3	2-141	HANDLE ONLY, HOT	ASSEMBLY	1
4	2-142	HANDLE ONLY, COLD	ASSEMBLY	1
5	3-178	ROMAN TUB SPOUT	ASSEMBLY	1
6	91231 91753	O-RING, #2-136, EPDM, 65-75 DURO	PART	2

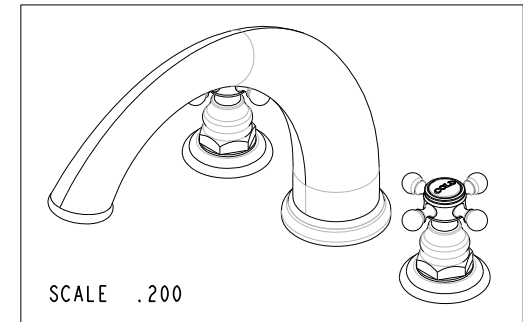
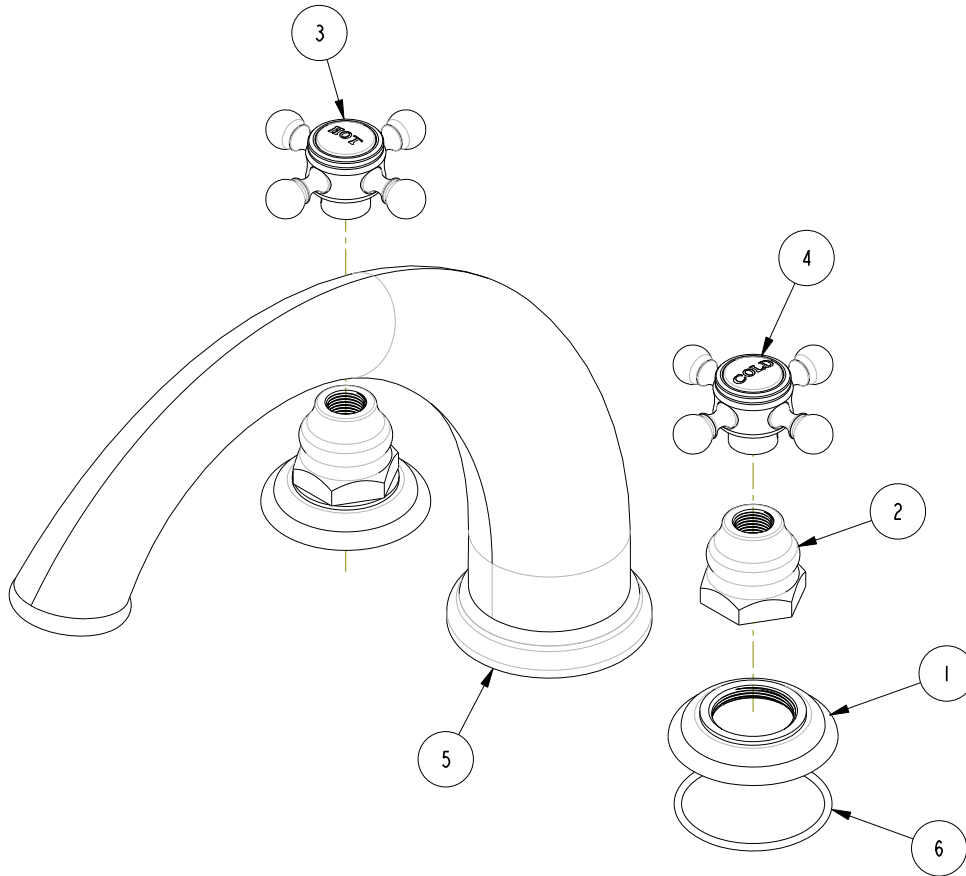

REV C EN-3722 02/08/2019 CG

ZONE	REV	DESCRIPTION	DATE	APPROVED
-	B	EN-2519b	12/09/15	AN
-	A	EN-2032	01/07/14	-

COPYRIGHT 2005 BRASSTECH, INC. THESE DRAWINGS AND THE DESIGNS DEPICTED HEREIN ARE THE PROPRIETARY PROPERTY OF BRASSTECH. ANY USE OR REPRODUCTION IS SUBJECT TO THE EXPRESS APPROVAL OF BRASSTECH. UNAUTHORIZED USE IS STRICTLY PROHIBITED. ALL RIGHTS RESERVED.

TESTING	-	-	-
ASSEMBLY	-	-	-
PLATING	-	-	-
POLISHING	-	NEXT ASSY	USED ON
MACHINING	-	APPLICATION	
TOOLING FIXTURE #	REMOVE ALL BURRS AND SHARP EDGES		

UNITS ARE: INCHES [MM]		
TOLERANCES ARE:		
FRACTIONS	DECIMALS	ANGLES
±1/16"	.X ±.1 (2.5)	±1°
	.XX ±.06 (1.5)	
(X.XXX) DENOTES CRITICAL DIMS.		
ALL THREADS ARE CRITICAL		
DRAWN	AN	12/09/15
CHECKED	AN	12/09/15
APPROVED	AN	12/09/15

BRASSTECH 2001 CARNEGIE AVE.
INCORPORATED SANTA ANA, CA 92705
(949) 417-5207

TRIM KIT - ROMAN TUB

DWG NO. **3-896** REV **C**

SCALE .375 REF. - SHEET 1 OF 5

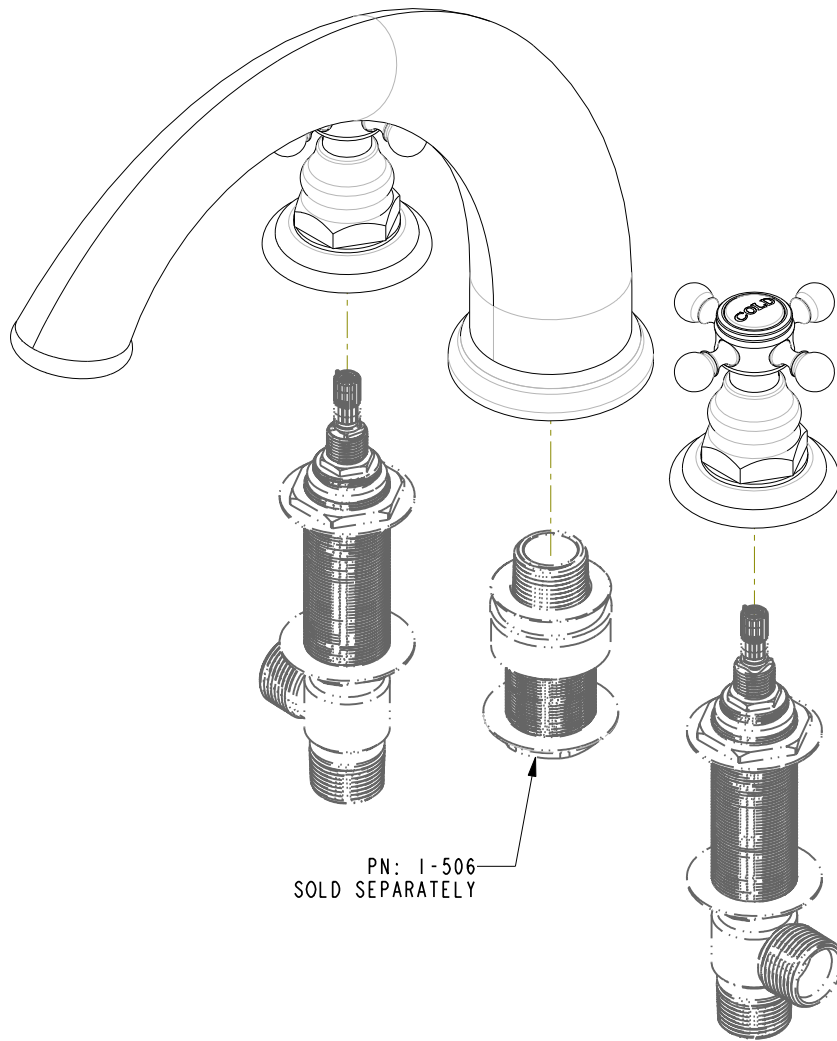

PN: 1-506
SOLD SEPARATELY

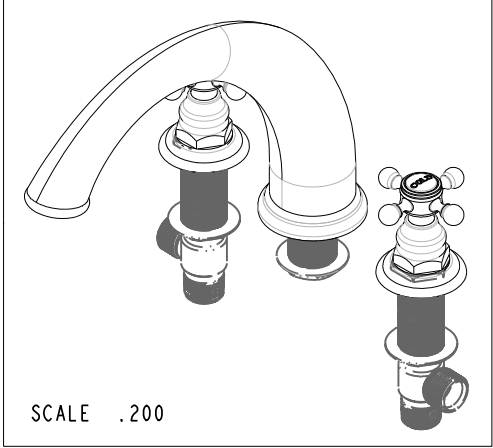

SCALE .200

BRASSTECH 2001 E. CARNEGIE AVE.
INCORPORATED SANTA ANA, CA 92705
(949) 417-5207

DWG NO.	3-896	REV	B
SCALE	.375	REF.	-
SHEET 2		OF 3	

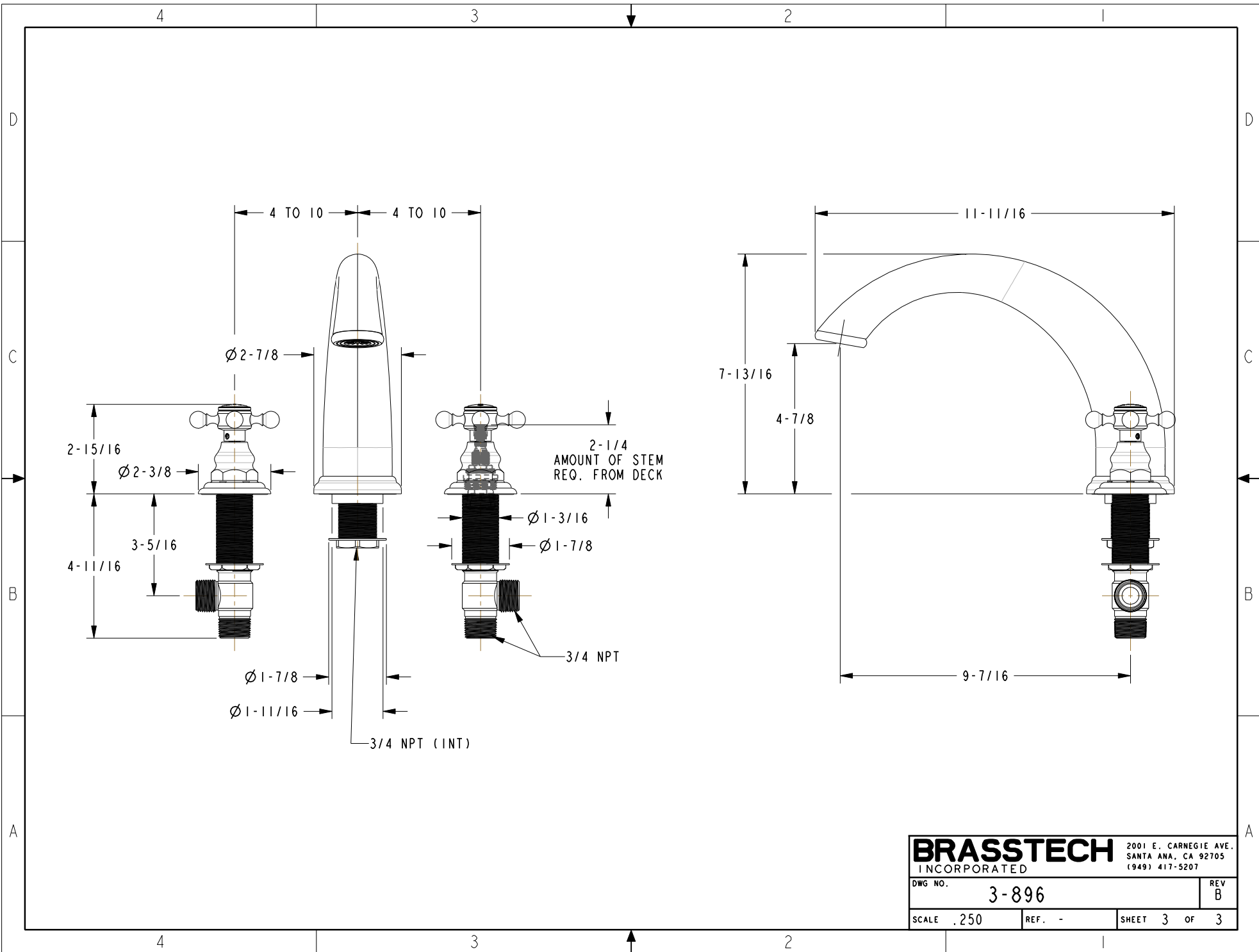

BRASSTECH 2001 E. CARNEGIE AVE.
 INCORPORATED SANTA ANA, CA 92705
 (949) 417-5207

DWG NO.	3-896	REV	B
SCALE	.250	REF.	-
SHEET 3 OF 3			