

NOTES:

1. TO INSPECT ASSEMBLY, FOLLOW FIRST ARTICLE AND IN PROCESS INSPECTION SHEET.
2. TRIM 3/8" OF SPLIT RING AND PLACE BETWEEN SPOUT AND BODY.
3. APPLY LOCTITE 242 IF SCREW DOES NOT HAVE NYLON PATCH.
4. APPLY LIGHT FILM OF DOW CORNING 111 SILICONE COMPOUND TO ALL O-RINGS PRIOR TO INSTALLATION.
5. APPLY LOCTITE 242.

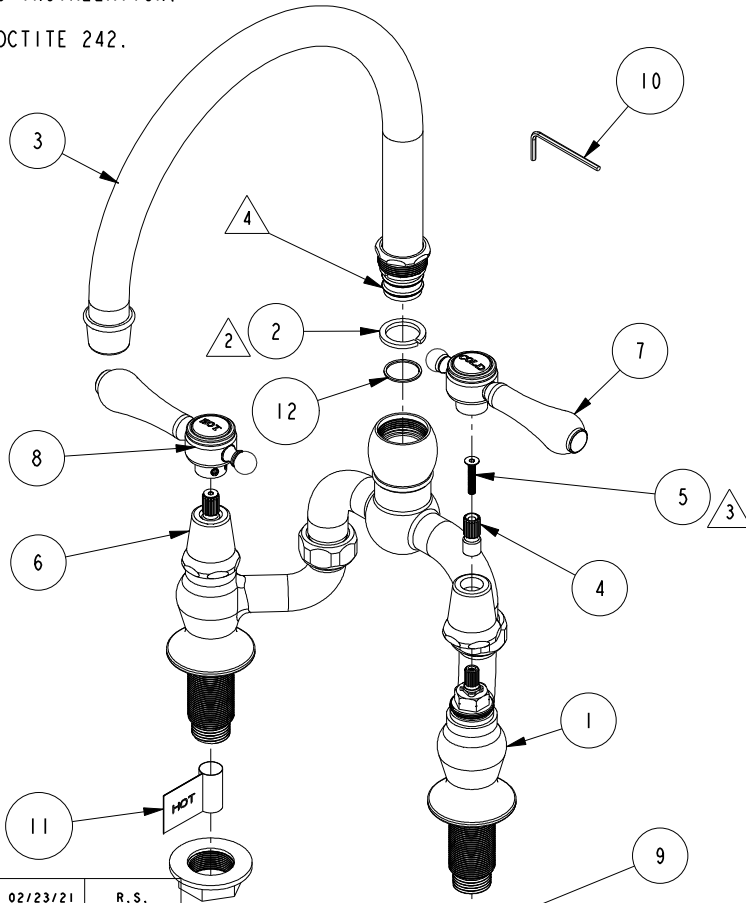

**BILL OF MATERIAL (CURRENT LEVEL)**

ITEM	PT/ASSY	DESCRIPTION	TYPE	QTY.
1	3-524	KITCHEN BRIDGE BODY ASM	ASSEMBLY	1
2	91111	SPLIT RING 3/4 X 1 NYLON	PART	1
3	3-525	SPOUT ASSEMBLY	ASSEMBLY	1
4	12062	ADAPTER - 20-T X 16-T	PART	2
5	92539	SCRW, M4X22 FLAT HD SOCKET HD CAP	PART	2
6	12259	HANDLE BONNET - TUB FILLER	PART	2
7	2-133	HANDLE ASSEMBLY - COLD	ASSEMBLY	1
8	2-134	HANDLE ASSEMBLY - HOT	ASSEMBLY	1
9	91473	FLANGE NUT 1.006"-20	PART	2
10	10159	HEX KEY, 3/32 ALLOY STEEL	PART	1
11	98044	LABEL - HOT	PART	1
12	91013	WSHR, .715 ID X .810 OD X .033 THK, DELRANT	PART	1

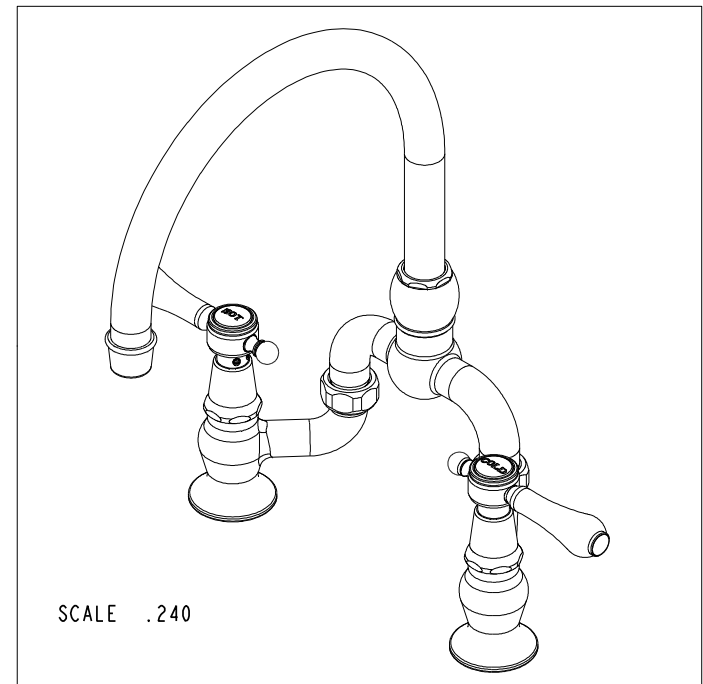

ZONE	REV	DESCRIPTION	DATE	APPROVED
-	G	EN-4300f	02/23/21	R.S.
-	F	EN-3879	10/14/19	C.G.
-	E	EN-3785	01/10/19	C.G.
-	D	EN-3688	08/27/18	C.G.
-	C	EN-3039b	05/03/16	AN
-	B	EN-2920	09/15/15	H.LE
-	A	EN-2907	06/19/15	-
-	-	EN-2855	01/26/15	-

COPYRIGHT 2005 BRASSTECH, INC. THESE DRAWINGS AND THE DESIGNS DEPICTED HEREIN ARE THE PROPRIETARY PROPERTY OF BRASSTECH. ANY USE OR REPRODUCTION IS SUBJECT TO THE EXPRESS APPROVAL OF BRASSTECH. UNAUTHORIZED USE IS STRICTLY PROHIBITED. ALL RIGHTS RESERVED.

TESTING	-	-	-
ASSEMBLY	-	-	-
PLATING	-	-	-
POLISHING	-	NEXT ASSY	USED ON
MACHINING	-	APPLICATION	
TOOLING FIXTURE #	REMOVE ALL BURRS AND SHARP EDGES		

UNITS ARE: INCHES [MM]	
TOLERANCES ARE:	
FRACTIONS	DECIMALS
±1/16"	.X ±.1 [2.5]
	.XX ±.06 [1.5]
(X.XXX) DENOTES CRITICAL DIMS. ALL THREADS ARE CRITICAL	
DRAWN	AMARISH 09/15/15
CHECKED	JINSON 09/15/15
APPROVED	RAVINDRA 09/15/15

**BRASSTECH** 2001 CARNEGIE AVE. SANTA ANA, CA 92705 (949) 417-5207  
INCORPORATED

**KITCHEN BRIDGE FAUCET**

DWG NO.	9463	REV	G
SCALE	.240	REF.	-
SHEET	1	OF	2

