

**OLMOS
59" ACRYLIC
OVAL TUB**

Cat. No.
ATOVN59AIG-WH



L: 59"
W: 31-1/8"
H: 23-3/4"

Water depth: 18-1/4" to top of tub
Water depth: 15" to overflow
Overflow hole diameter: 4"
Center drain to back of rim: 15-3/4"
Bottom of drain to floor: 3-3/8"
Bathing well to floor: 5-1/4"
Sitting area: 19-1/2"

The following is recommended for ATOVN59AIG tubs without faucet holes:

- Faucets: Part #4602, 4022, and 4025
- Rigid, freestanding supplies, part #4502
- Freestanding filler, part #7932, 7952, or 7918 (Supplies included with filler)



For easier installation we recommend use of 5598-ITD Easy Install Rough In Kit

Gallon Capacity: 77
Shipping Weight: 142 lbs.
Empty Weight: 99 lbs.
Filled Weight: 738 lbs.

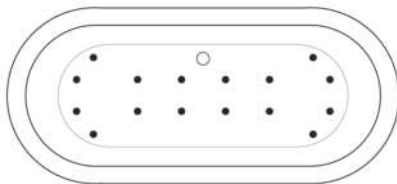

(Air jet configuration if system is added, more info on page 2.)

Features:

- ▶ Acrylic construction for lighter weight
- ▶ Interior and exterior walls acrylic sheets
- ▶ Overflow slot with integrated drain
- ▶ Drain included
- ▶ Drain and overflow covers included(available in 6 finishes)
- ▶ Rim is 1-1/2" wide
- ▶ No faucet holes with Tap Deck
- ▶ Includes built-in adjusters
- ▶ Angle slope of tub: 55°
- ▶ Tub is thoroughly inspected before shipment
- ▶ Option to add foam insulation between tub walls available
- ▶ New: Air jet system now available, more info on page 2



Finishes:

- BN Brushed Nickel
- CP Polished Chrome
- ORB Oil Rubbed Bronze
- PB Polished Brass
- PN Polished Nickel
- WT White

Custom Colors Available (inside of tub is always white enamel):
Painted bathtubs are considered "special order" and are not returnable
\$160 Bisque or Black \$250 Designer Color

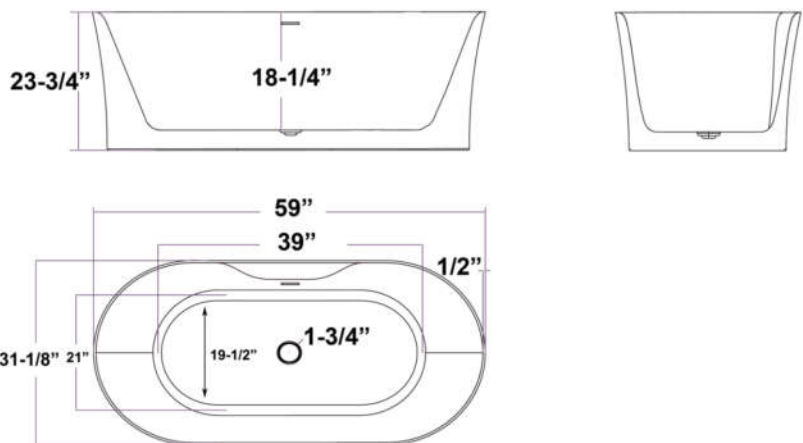

Dimensions of fixture are nominal and specifications subject to change without notice.