

INSTALLATION INSTRUCTIONS

Pressure Balancing Valve

Valve Body No. I-685

as used with Tub and Shower Fittings



Note: This valve is designed to fit in a 2" X 4" stud wall (or thicker) installation. Use stem extension kit #I-249 (sold separately) if valve installed is too far away from the finished wall.

Description

This valve is precision engineered to provide satisfactory performance provided it is installed and operated in accordance with our recommendations contained in these instructions. In order to fully enjoy the comfort, safety and the reliability of this valve, be certain to familiarize yourself with these instructions.

Operation

The pressure balancing cartridge contained in this valve compensates for pressure fluctuations in the water supply system through a spool and sleeve pressure balancing mechanism. The outlet temperature will change by no more than a mere $\pm 2^{\circ}\text{F}$ (1°C) with a 50% drop in either the hot or cold water pressure. Even if the cold water pressure fails completely, the anti-scald design will reduce the flow rate to a safe level ensuring reliable protection against scalding. The built-in check valves prevent cross flow between the hot and cold supplies.

SPECIFICATIONS

Min Operating pressure: 20 psi [140 Kpa]

Max. Operating pressure: 125psi [860 Kpa]

Max. Burst pressure: 500 psi [3450Kpa]

Max. Hot water temp: 180 °F [80° C]

Flow rate in USGPM [l/min] @ 50psi [345 Kpa]

	Tub		Shower	
1-685(Automatic)	5.8	22	5.8	22

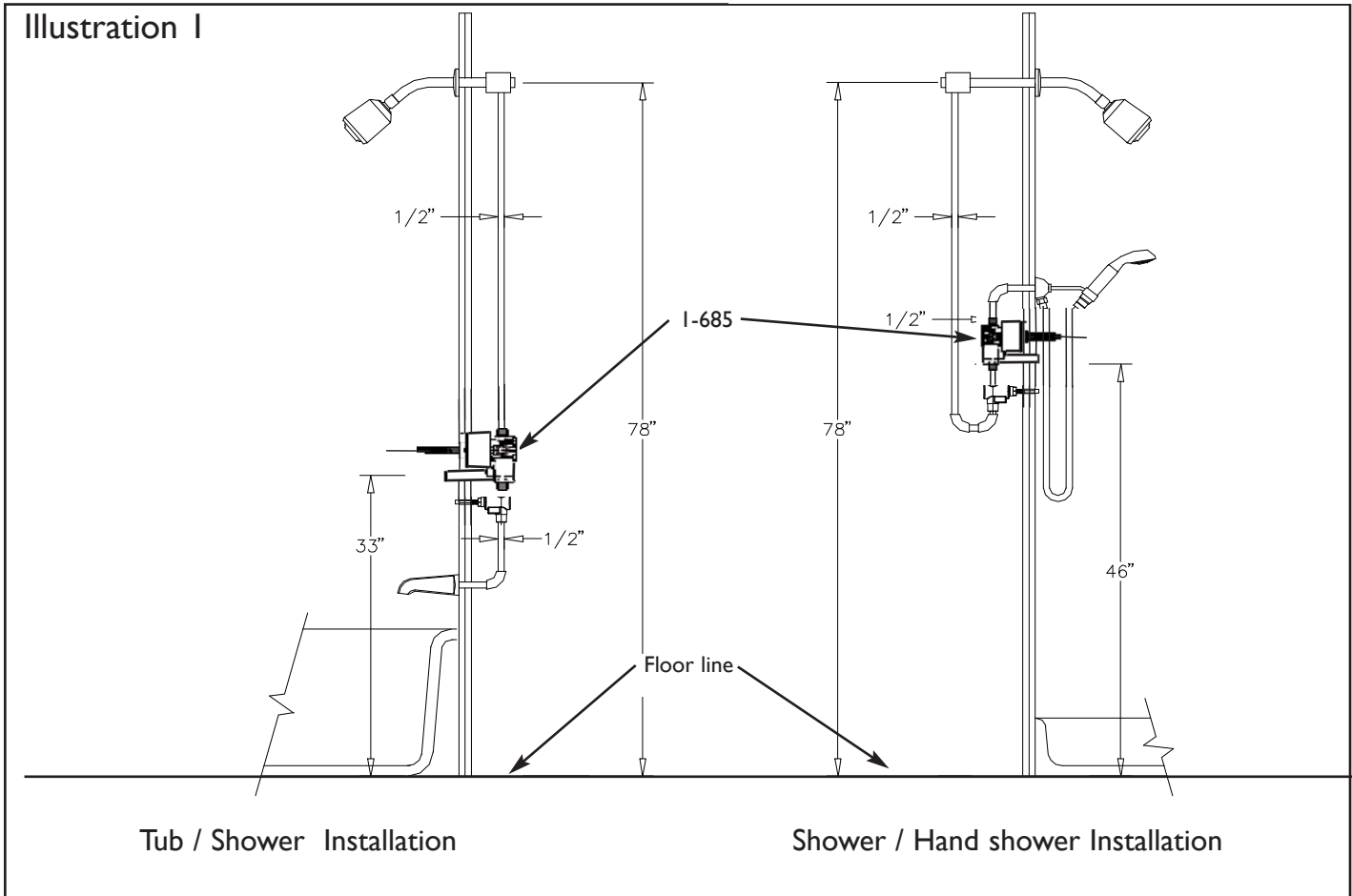

BEFORE YOU BEGIN

On tiled wall surfaces, grouting must be either flush or raised for proper sealing of the cover plate.

IMPORTANT: It is not necessary to remove the cartridge from the valve during NORMAL soldering operations using propane-butane gas. **DO NOT USE OXYGEN-ACETYLENE.** When soldering connections, do not solder within 4" of valve port. Do not use excessive heat. Open the stop valves when soldering inlets.

It is recommended that the pipes be flushed clean prior to installation, in order to avoid any future problems.

Ensure that the stop ring is properly installed, see below, otherwise a user could potentially disengage the cartridge with minimal force to external handle. This would cause the valve to fail, losing control of flow & temperature.

Make sure valve is securely fastened to studs. Be sure to remove trim items, handles, escutcheons and plates before installation. Wrap carefully and store until finished wall is completed.

Install the valve by positioning the 1/2" shower outlet in the up position. If installing showerhead & hand shower configuration, plumb showerhead from tub port (T) and hand shower from shower port (S). Finished wall must be within dimensions shown in illustration 2. To test pipe joints, pressurize both hot and cold inlets.

Installing Trim

Thread plastic upper link into finished post. Insert assembled post onto end of diverter stem, then slide finished sleeve over attached items and screw sleeve into diverter housing. Place coverplate on valve stem while sliding diverter trim through rubber grommet. Screw on escutcheon trim and mark all-thread nipple where excess needs to be cut off.

(NOTE: For stem to be fully seated into cartridge, all-thread nipple and locking nut must be tightly secured against retaining plate.) Place handle on stem. Measure excess between escutcheon and handle base. Remove handle and cut previously measured excess from end of stem. Secure handle into place by tightening the handle setscrew or tightening the bonnet depending on handle construction. Screw diverter knob onto finished post. (Refer to Illustrations 2 and 3.)

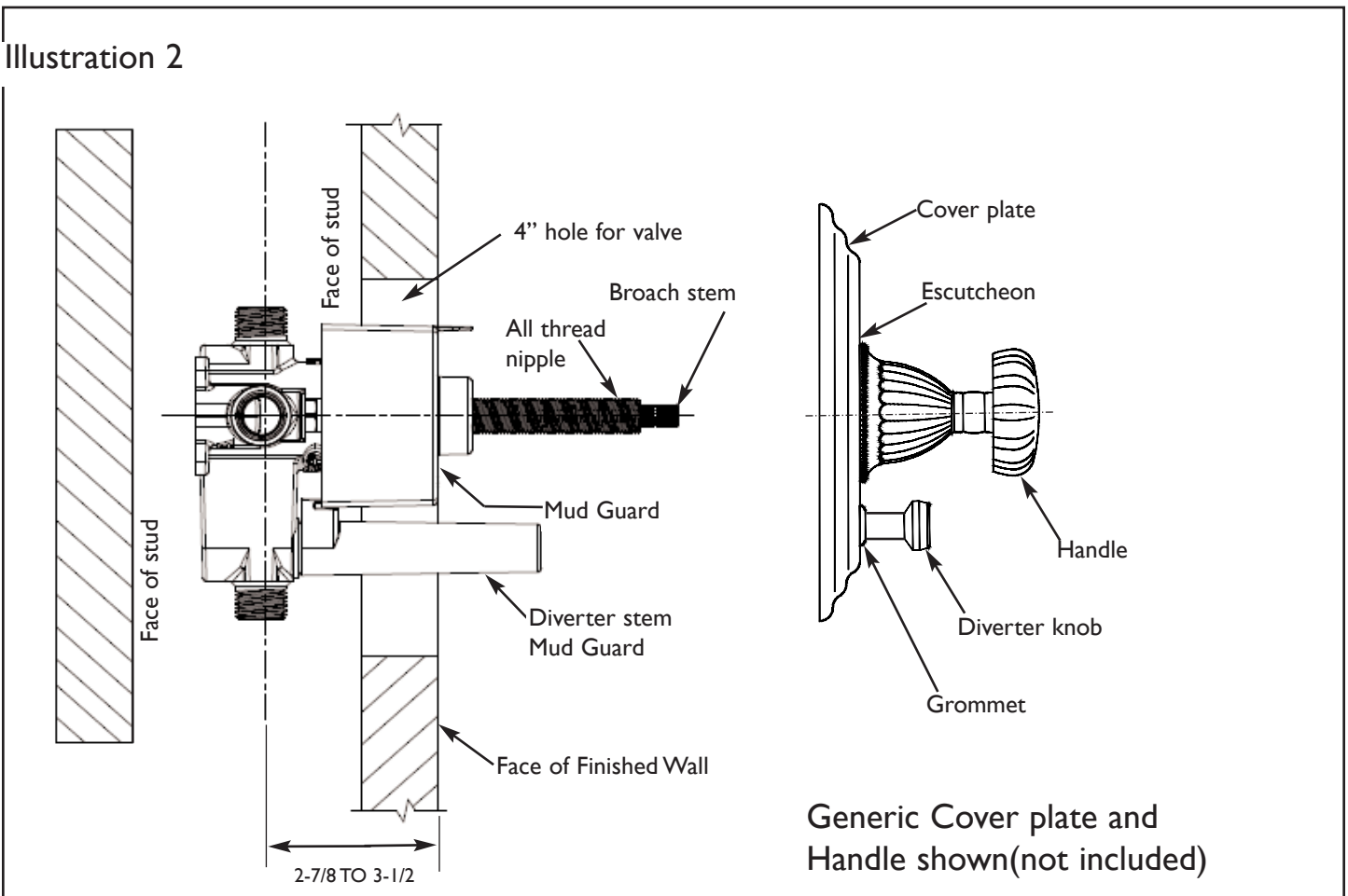

NOTE: Dimensions shown are from the inlet ports to the finished wall.

Illustration 3

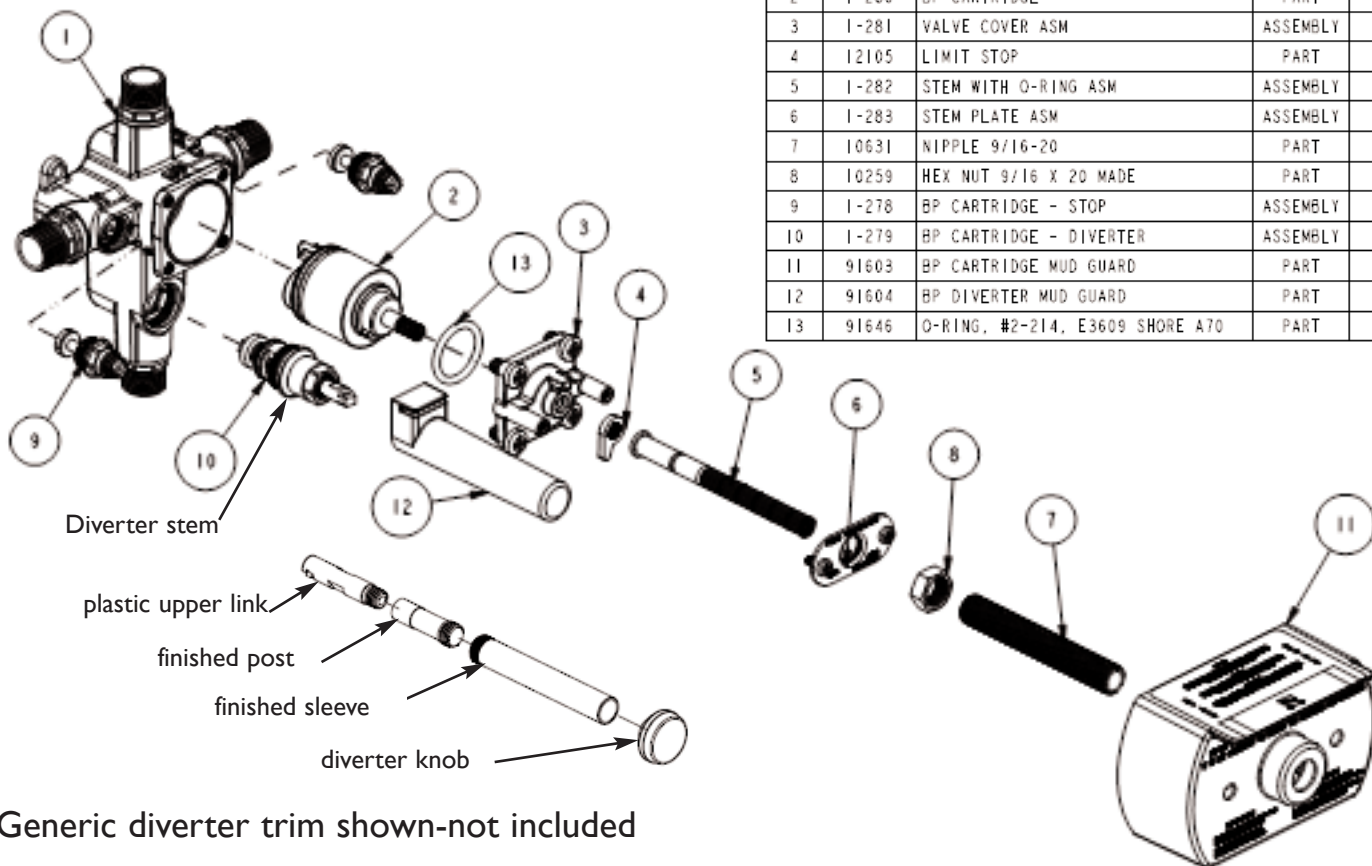

ITEM	PT/ASSY	DESCRIPTION	TYPE	QTY.
1	1-285	DIVERTER BP VALVE BODY W/ ADAPTERS	ASSEMBLY	1
2	1-280	BP-CARTRIDGE	PART	1
3	1-281	VALVE COVER ASM	ASSEMBLY	1
4	12105	LIMIT STOP	PART	1
5	1-282	STEM WITH O-RING ASM	ASSEMBLY	1
6	1-283	STEM PLATE ASM	ASSEMBLY	1
7	10631	NIPPLE 9/16-20	PART	1
8	10259	HEX NUT 9/16 X 20 MADE	PART	1
9	1-278	BP CARTRIDGE - STOP	ASSEMBLY	2
10	1-279	BP CARTRIDGE - DIVERTER	ASSEMBLY	1
11	91603	BP CARTRIDGE MUD GUARD	PART	1
12	91604	BP DIVERTER MUD GUARD	PART	1
13	91646	O-RING, #2-214, E3609 SHORE A70	PART	1

Generic diverter trim shown-not included

ASM 1-281

ITEM	PT/ASSY	DESCRIPTION	TYPE	QTY.
1	12104	VALVE COVER	PART	1
2	91031	O-RING, #2- 129, EPDM EP7001, 65-75 DURO, NSF 61	PART	1
3	91650	O-RING, 2 X 7.5MM ID, S7008F, 65-75 DURO	PART	1
4	92244	SCRW, 1/4-20 X 1/2 PHL PAN HD SS	PART	4

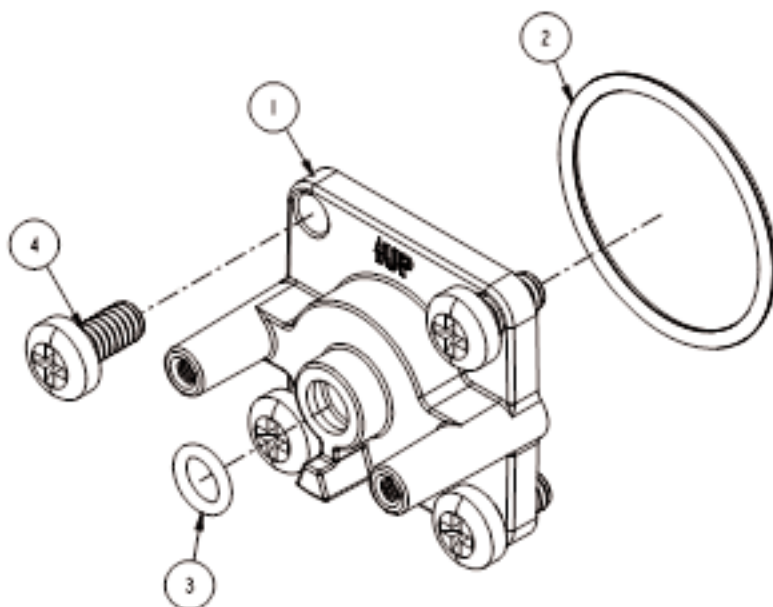

Setting the Temperature Limit Stop

This valve has an upper temperature limit stop, which can allow desired and safe hot water temperature (recommended maximum is 110°F). This stop may be adjusted once the valve is installed.

Before making this adjustment, run water with the valve turned to the hot setting. If the water temperature is too high in this position, then perform the following adjustments:

1. Remove the trim (handle, escutcheon and cover).
2. Remove the all-thread nipple, (item 7), hex nut (item 8) and stem plate (item 6).
3. Remove the broach stem (item 5) and the limit stop (item 4).
4. Close the valve by turning the cartridge stem clockwise until it stops, (Illustration 4).
5. From the CLOSED position, rotate the cartridge stem counter-clockwise until the desired temperature is achieved.(Illustration 5).
6. Place the limit stop (item 4) on the cartridge stem against the stop block (Illustration 6). Rotate several times to make sure the stop is at the desired temperature setting.
7. Install the broach stem (item 5), stem plate (item 6), all thread nipple (item 7) and hex nut (item 8).(NOTE : For broach stem to be fully seated onto cartridge, the all thread nipple (item 7) and hex nut (item 8) must be tightly secured against the retaining plate).

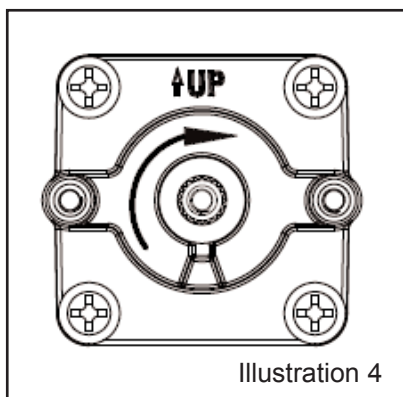

Illustration 4

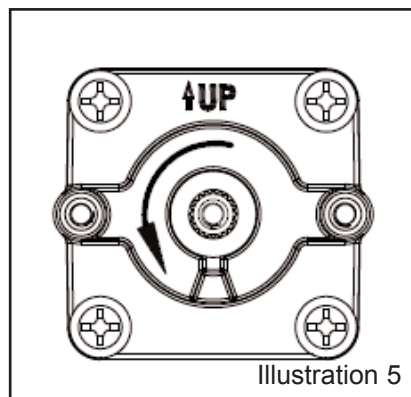

Illustration 5

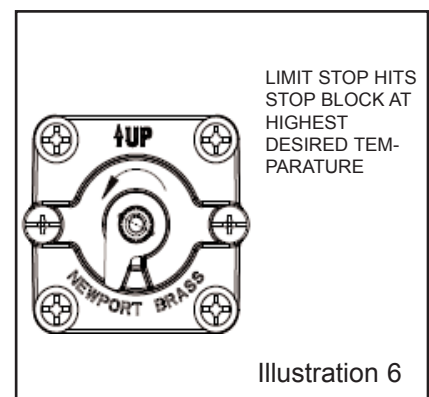

Illustration 6

* **WARNING** - Never try to stop dripping by applying extreme force or overtightening the handle.

MALFUNCTION	CAUSE	REMEDY
Opening immediately to hot water.	Hot and cold water supplies have been connected in reverse.	Rotate cartridge 180degrees. (Illustration 7)
Water drips after shutting off the valve.	Residual water in valve and piping.	Allow approximately 3-8 minutes to drain.*
Water leak from valve	O-ring seal on the inlet of the cartridge is faulty or seat assembly is damaged.	Check the O-ring & seat for cuts or overheating damage during installation. Replace if necessary.
Water insufficiently hot.	Adjustable handle position stop incorrectly set.	Refer to the instruction on "Setting Temperature Limit Stop".
Valve body too deep into wall.	The measured rough in or finished wall surface is incorrect.	Reset the valve.
Diverter will not stay on during shower.	Not enough backpressure between showerhead and diverter valve.	Ensure a 2.0 GPM flow restrictor is mounted at the shower head.
No or low flow of hot or cold water.	Either the hot or cold side is not fully pressurized.	Verify that the service stops for both the hot and cold are fully open (turn counterclockwise) and pressurized. Illustration 8.
	Debris caught inside the inlet of the cartridge.	Remove the cartridge (See Page 3). If debris is lodged in the inlet of the cartridge. The debris can be removed with a straightened paper clip or fine wire. Gently insert the wire and move it in a circular motion to dislodge any debris.

