

# Pose 7236 IF Acrylic Corner Left Bathtub

**Model number:**

106211-L-097-001

**Dimensions:** 71.5" x 35.375" x 23.625"

**Installation:** Corner

**Material:** Acrylic



## Standard Features:

- Rectangular shape bathtub with choices of two deck heights (3/8 or 2 in.) Please specify when ordering.
- Integrated flange (IF) for corner installation
- Textured floor
- Ample deck space for faucet installation
- Right or left drain available

## Product characteristics:

- Integrated Tiling Flange
- Easy Installation
- Textured Floor

## Systems:

- Whirlpool
- Combined Whirlpool/Aeroeffect
- Aeroeffect

## Standard Colors:



White (001)



Bone (004)



Biscuit (007)

## Certifications

MAAX products adhere to one or more of the following certifications:



# MAAX

# Pose 7236 IF Acrylic Corner Left Bathtub

**Model number:**

106211-L-097-001

**Dimensions:** 71.5" x 35.375" x 23.625"

**Installation:** Corner

**Material:** Acrylic

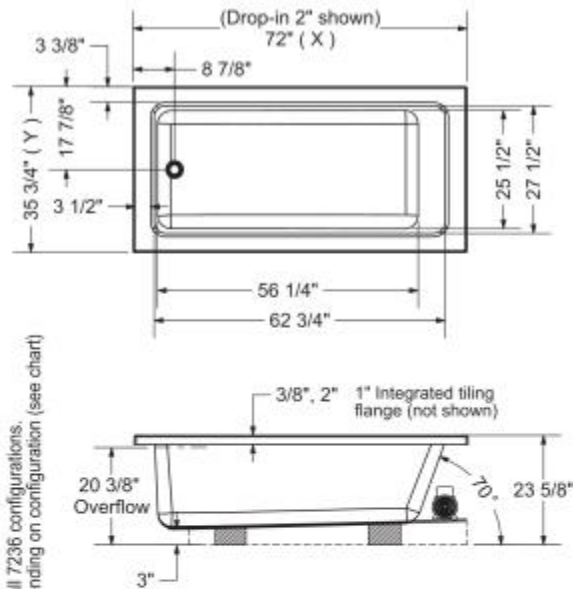

Technical drawing is universal for all 7236 configurations. External dimension (X,Y) vary depending on configuration (see chart)

	DROP IN 2"	DROP IN 3/8"	ALCOVE / CORNER
X	72"	71 7/8"	71 1/2"
Y	35 3/4"	35 5/8"	35 3/8"

Wood support design may vary.  
Integrated tiling flange: 1" height X 1/4" thickness (not shown)  
Tiling flange position is determined by chosen configuration.  
All dimensions are approximate.  
Structure measurement must be verified against the unit to ensure proper fit.

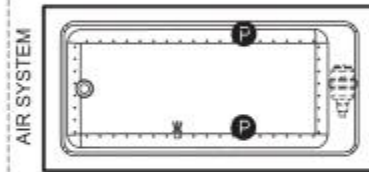
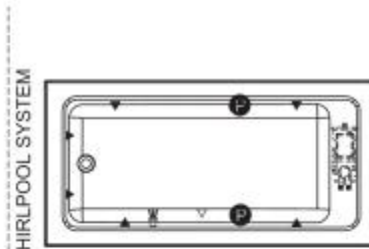

- : Indicates optional grab bar positioning
- ( ▲ ) : Indicates whirlpool jets positioning
- ( △ ) : Indicates suction positioning
- ( ● ) : Indicates airjets positioning
- ( ☼ ) : Indicates chromatherapy light positioning

APRON (alcove version only)

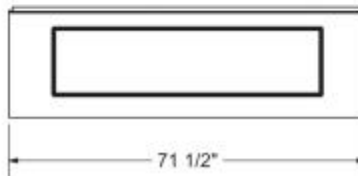

## Dimensions

71 1/2 x 35 1/2 x 23 3/4 In.  
(1816 x 899 x 600 mm)

## Water Capacity

90 gallons - 341 liters

## Weight

82 lbs - 37 1/4 kg

## Bathing Well

62 3/4 In. x 27 1/2 In.

## Deep Sump Height

19.5 In. - 495 mm

## Deck Width

3.375 In. - 86 mm

## Drain location:

Left

Right

Project:

Contractor:

Representative:

Date:

Tel:

Notes:

# MAAX