

Exhibit 6042 Acrylic Drop-in Bathtub

Model number:

106250-103-004

Dimensions: 59.875" x 42" x 18"

Installation: Drop-in

Material: Acrylic



Standard Features:

- Rectangular shape bathtub
- Drop-in or alcove installation with tiling flange
- Minimalist look with discreet armrests and textured floor
- End drain

Product characteristics:

- Made in North America
- Integrated Armrest
- Therapy System Available

Systems:

- Product Pack
- Whirlpool
- Combined Whirlpool/Aeroeffect
- Aeroeffect

Standard Colors:



White (001)



Bone (004)



Biscuit (007)

Certifications

MAAX products adhere to one or more of the following certifications:



MAAX

Exhibit 6042 Acrylic Drop-in Bathtub

Model number:

106250-103-004

Dimensions: 59.875" x 42" x 18"

Installation: Drop-in

Material: Acrylic

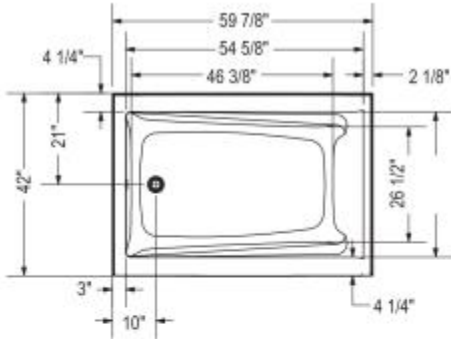

1" Single integrated tiling flange (not shown)
Drop-in model (Shown)

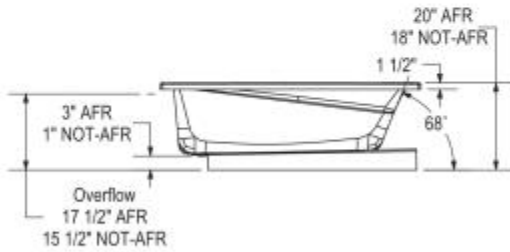

Technical drawing is universal for all Exhibit 6042 configurations.

Wood support design may vary.
Single Integrated tiling flange: 1" height x 1/4" thickness (not shown)

All dimensions are approximate.
Structure measurement must be verified against the unit to ensure proper fit.

IFS Without System
Single tiling flange



IFS With System
(access panel)
Single tiling flange

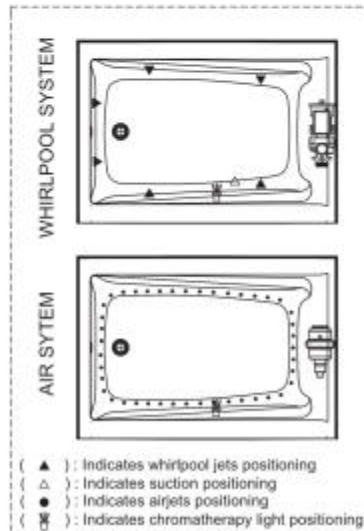

- (▲) : Indicates whirlpool jets positioning
- (△) : Indicates suction positioning
- (●) : Indicates airjets positioning
- (☼) : Indicates chromatherapy light positioning

Dimensions

60 x 42 x 18 In.
(1521 x 1067 x 457 mm)

Water Capacity

68 gallons - 259 liters

Weight

73 lbs - 33 kg

Bathing Well

54 3/4 In. x 33 1/2 In.

Deep Sump Height

16.375 In. - 416 mm

Deck Width

4.25 In. - 108 mm

Drain location:

End

Project: _____

Contractor: _____

Representative: _____

Date: _____

Tel: _____

Notes: _____

MAAX