

Pose 6032 IF Acrylic Corner Left Bathtub

Model number:

106202-R-003-004

Dimensions: 59.625" x 31.625" x 23.625"

Installation: Corner

Material: Acrylic



Standard Features:

- Rectangular shape bathtub with choices of two deck heights (3/8 or 2 in.) Please specify when ordering.
- Integrated flange (IF) for corner installation
- Textured floor
- Ample deck space for faucet installation
- Right or left drain available

Product characteristics:

- Integrated Tiling Flange
- Easy Installation
- Textured Floor

Systems:

- Whirlpool
- Combined Whirlpool/Aeroeffect
- Aeroeffect

Standard Colors:



White (001)



Bone (004)



Biscuit (007)

Certifications

MAAX products adhere to one or more of the following certifications:



MAAX

Pose 6032 IF Acrylic Corner Left Bathtub

Model number:

106202-R-003-004

Dimensions: 59.625" x 31.625" x 23.625"

Installation: Corner

Material: Acrylic

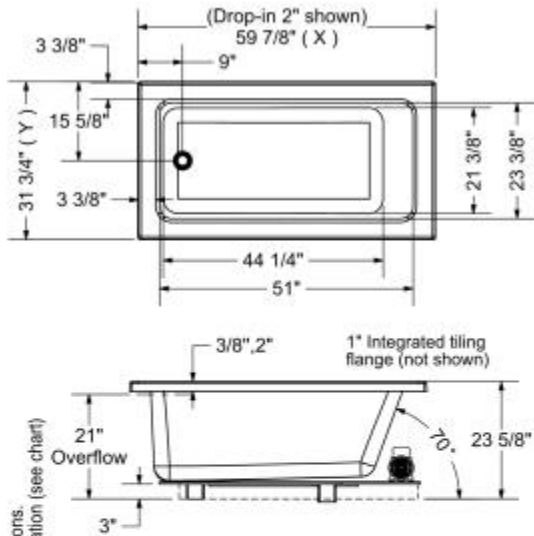

Technical drawing is universal for all 6032 configurations. External dimension (X,Y) vary depending on configuration (see chart)

	DROP IN 2"	DROP IN 3/8"	ALCOVE / CORNER
X	59 7/8"	59 3/4"	59 5/8"
Y	31 3/4"	31 5/8"	31 5/8"

Wood support design may vary.
 Integrated tiling flange: 1" height X 1/4" thickness (not shown)
 Tiling flange position is determined by chosen configuration.
 All dimensions are approximate.
 Structure measurement must be verified against the unit to ensure proper fit.

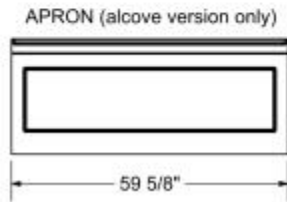
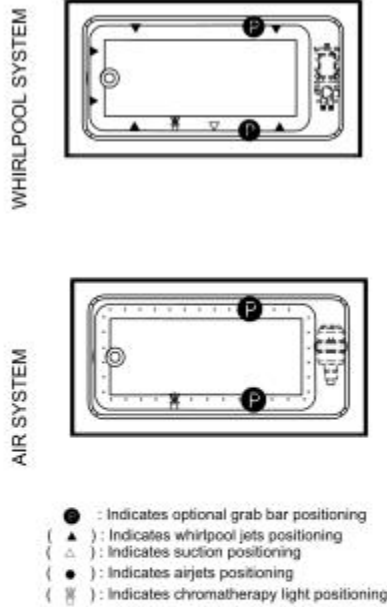

Dimensions

59 3/4 x 31 3/4 x 23 3/4 In.
 (1514 x 803 x 600 mm)

Water Capacity

64 gallons - 241 liters

Weight

61 lbs - 27 3/4 kg

Bathing Well

51 In. x 23 1/2 In.

Deep Sump Height

18 In. - 457 mm

Deck Width

3.375 In. - 86 mm

Drain location:

Left

Right

Project:

Contractor:

Representative:

Date:

Tel:

Notes:

MAAX