

SPECIFICATIONS

DESCRIPTION

- Remote on/off air switch button for activating garbage disposals
- Solution for island countertops or where an electrical switch is not available
- Control box with mounting hardware included

WARRANTY

- Most products or parts carry "Limited Warranties" against manufacturing defects. For US customers please visit houseofrohl.com/support and for Canadian customers please visit houseofrohl.ca/support for complete product and finish warranty.



Waste Disposal Control Box With Air Switch Button

MODEL: AS450

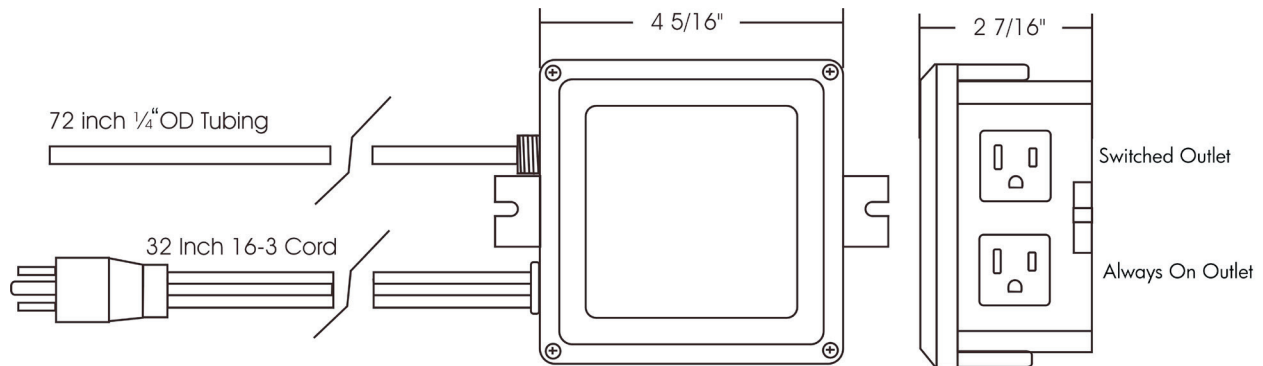

For warranty or additional information, contact:

U.S.A.
houseofrohl.com/support
 1-800-777-9762

QUEBEC / MARITIMES / WESTERN CANADA
 QUÉBEC / MARITIMES / OUEST CANADIEN
 QUEBEC / MARITIMOS / CANADA OCCIDENTAL
houseofrohl.ca/support
 1-866-473-8442

ONTARIO
houseofrohl.ca/support
 1-800-287-5354

SPECIFICATIONS

DESCRIPTION

- Remote on/off air switch button for activating garbage disposals
- Solution for island countertops or where an electrical switch is not available

WARRANTY

- Most products or parts carry "Limited Warranties" against manufacturing defects. For US customers please visit houseofrohl.com/support and for Canadian customers please visit houseofrohl.ca/support for complete product and finish warranty.



Waste Disposal Air Switch Button

MODEL: AS425

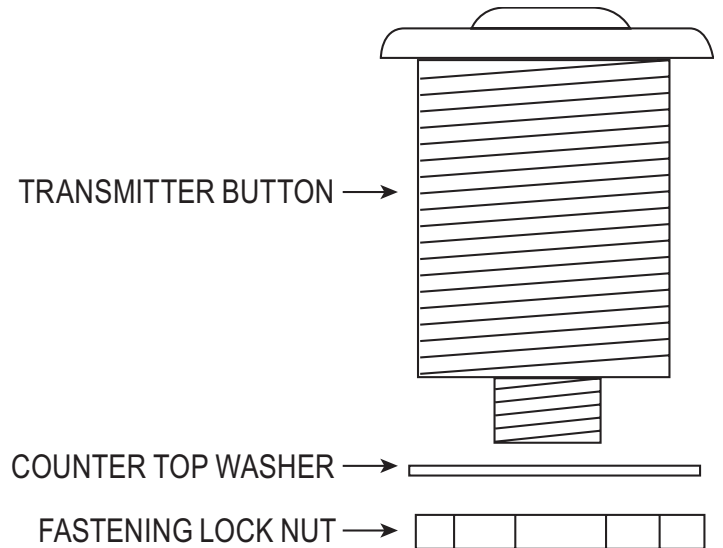
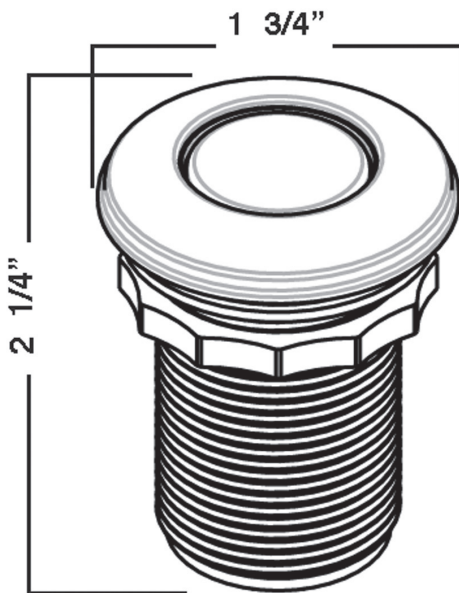

For warranty or additional information, contact:

U.S.A.
houseofrohl.com/support
 1-800-777-9762

QUEBEC / MARITIMES / WESTERN CANADA
 QUÉBEC / MARITIMES / OUEST CANADIEN
 QUEBEC / MARITIMOS / CANADA OCCIDENTAL
houseofrohl.ca/support
 1-866-473-8442

ONTARIO
houseofrohl.ca/support
 1-800-287-5354