

PRODUCT SPECIFICATIONS

Dayton 3-1/2" Stainless Steel Drain with Removable Basket Strainer and Rubber Stopper (sold in multiples of 36). Overall dimensions are 4-5/8" x 4-5/8" x 2-13/16". Made of Stainless Steel.

Material:	Stainless Steel
Finish:	Matte
Dimensions:	4-5/8" x 4-5/8" x 2-13/16"
Shipping Weight:	1 lbs.

Special Note: Fits 3-1/2" drain opening

NOTE: MUST BE ORDERED IN MULTIPLES OF 36

- Strainer basket with metal stem and rubber seal.



AMERICAN PRIDE. A LIFETIME TRADITION.
Like your family, the Elkay family has values and traditions that endure. For almost a century, Elkay has been a family-owned and operated company, providing thousands of jobs that support our families and communities.

Product Compliance: ASME A112.18.2/CSA B125.2

[Clean and Care Manual \(PDF\)](#)
[Installation Instructions \(PDF\)](#)

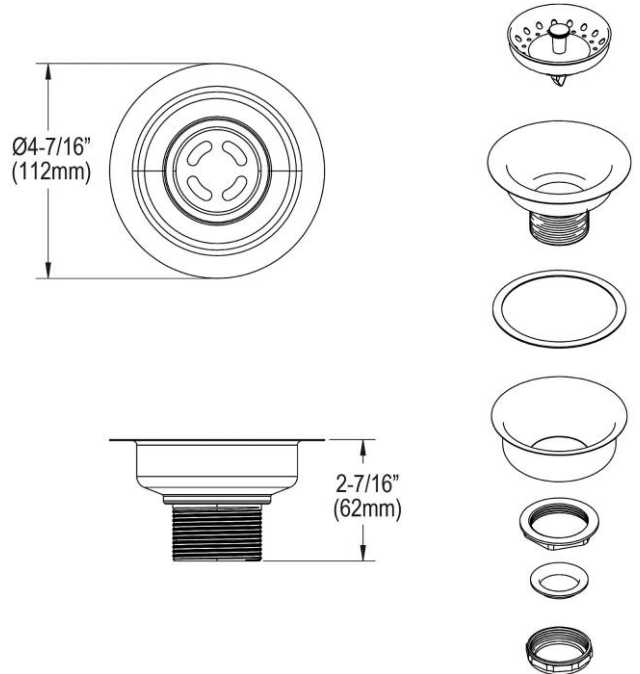

PART: _____ QTY: _____

PROJECT: _____

CONTACT: _____

DATE: _____

NOTES: _____

APPROVAL: _____

In keeping with our policy of continuing product improvement, Elkay reserves the right to change product specifications without notice. Please visit elkay.com for the most current version of Elkay product specification sheets. This specification describes an Elkay product with design, quality, and functional benefits to the user. When making a comparison of other producers' offerings, be certain these features are not overlooked.