Installation instructions	Freestanding bathtub
Notice de montage	Baignoire autoportante
Instrucciones de montaje y uso	Bañera de pie

Cape Cod

70033090

DuraSquare

70043090

Happy D.2 Plus

70045390

Luv

70043490

Vero Air

70041890

	Important information	4
	Installation	5
<hr/>		
	Remarques importantes	12
	Montage	13
<hr/>		
	Información importante	20
	Montaje	21

en

fr

es



en

About these instructions

The installation instructions come as part of the Duravit product and must be read carefully prior to installation.

Target readership and qualifications

This is a professional grade product. A working knowledge of construction techniques and code compliant plumbing installation are required for proper installation and user satisfaction. The product must be installed by a licensed plumber.

Explanation of the key words and symbols

NOTICE

Is used to address practices not related to physical injury.



Inspection (e.g. for scratches)



Inspect for leaks and that all connections have a watertight seal



Indication of the length of time (e.g. 10 minutes)

> Action required

Safety instructions

Product and/or property damage

The breach of local and country-specific regulations and standards can cause damage to the product and/or property damage.

- > Observe the local installation regulations and any country-specific standards at all times.

Careless handling can result in damage to the surface of lacquered bathtubs.

- > Protect the bathtub from knocks and scratches during installation and transport.

Prior to the installation

Please read the specifications sheets prior to the installation. Specification sheets are available for download at www.pro.duravit.us.

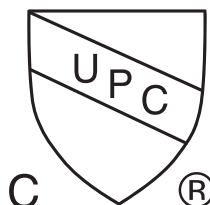

Products are in compliance with the following codes:

- Uniform Plumbing Code (UPC®)
- National Plumbing Code of Canada



Delivery contents

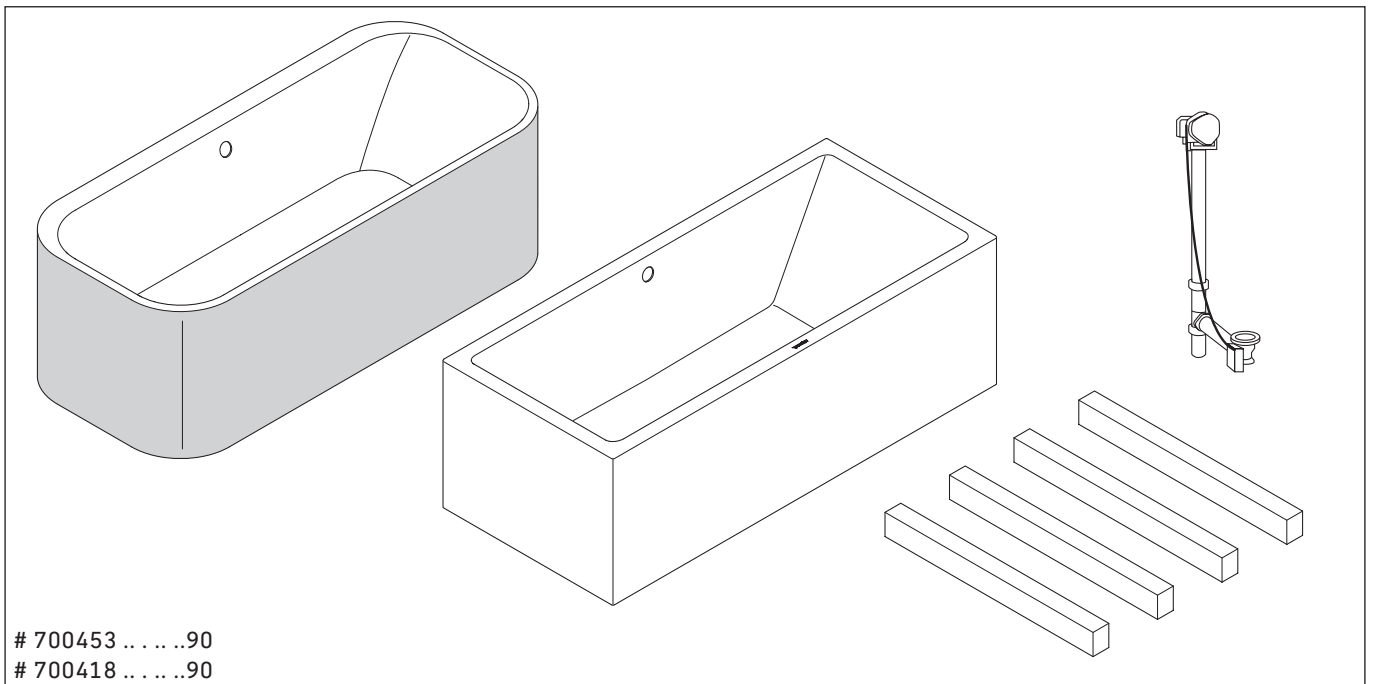
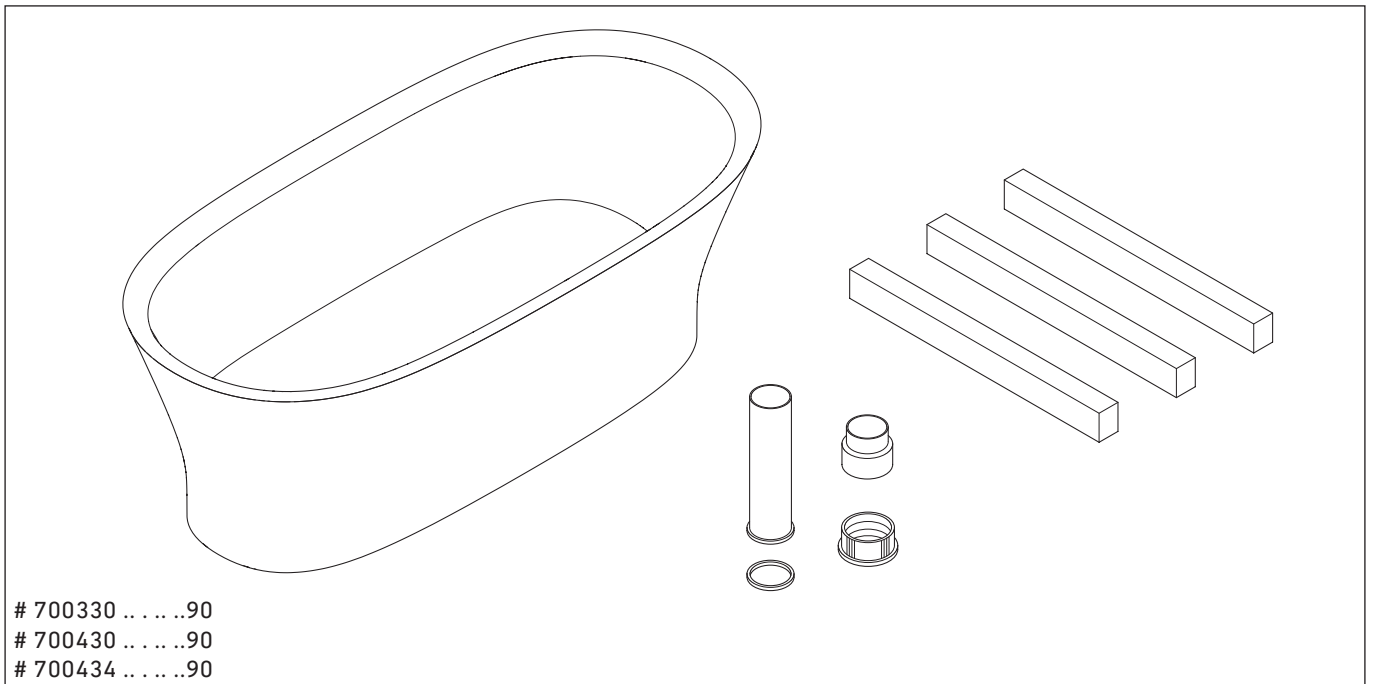

**Optional accessories (not included)**

Freestanding in-floor bathtub drain

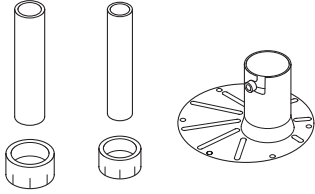

791281 (PVC)

791282 (ABS)

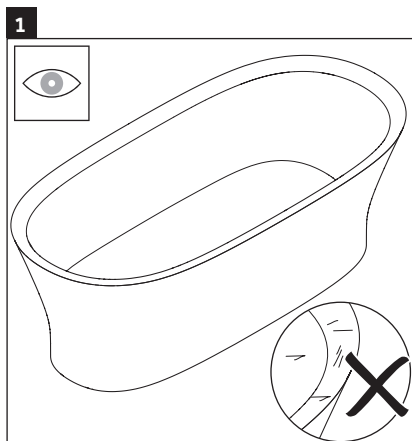

- > Inspect bathtub for any potential damage that may have occurred during transport.
- > Do not install if any damage is visible.

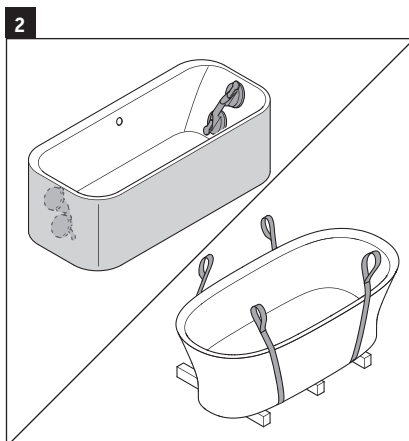

NOTICE

- Suction lifters can cause damage to the surface of lacquered bathtubs.
- > Attach suction lifters to the inside of lacquered bathtubs to avoid damage to lacquered surface.

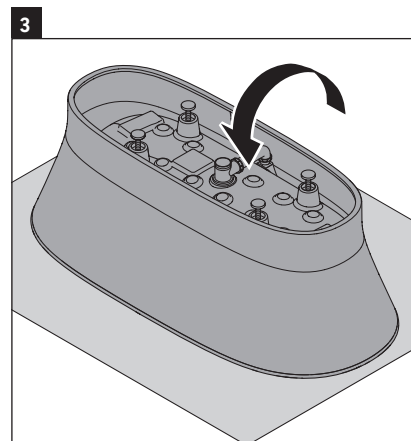

NOTICE

- Tilting the bathtub on its side can damage the bathtub.
- > Place cardboard/blanket on the floor.
 - > Turn bathtub over.

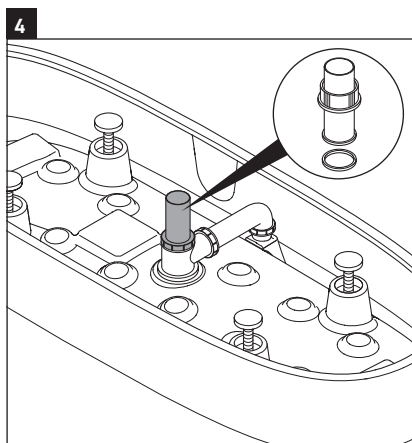

- > Connect tailpiece to the bathtub drain.

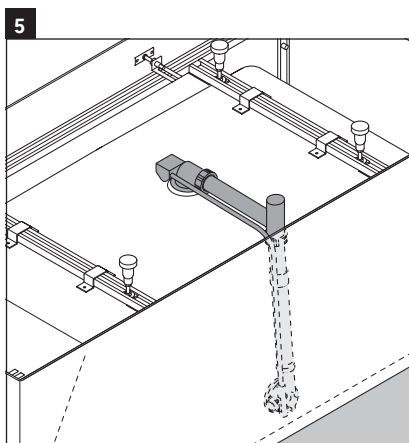

- For Vero Air/Happy D.2 Plus:**
- > Connect waste and overflow.

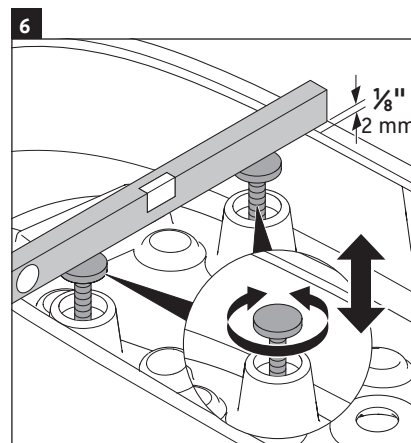

- > Level the feet before setting the bathtub.



en

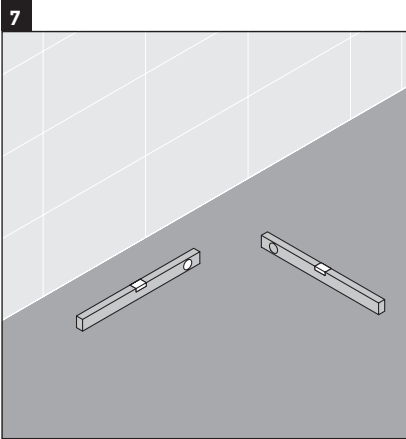

- > Ensure floor area is clear and level.
- > Compensate irregularities by adjusting tub feet.

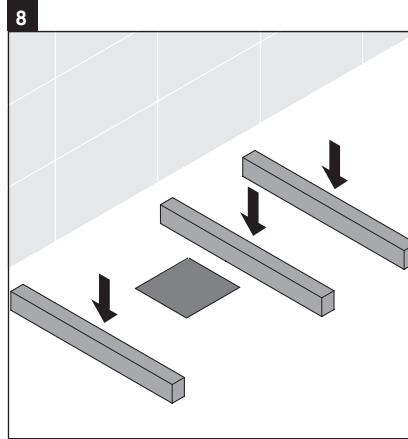

- > Observe the dimensions from diagram 9 to 13 for the positioning of the drain.
- > Position the installation aids accordingly.

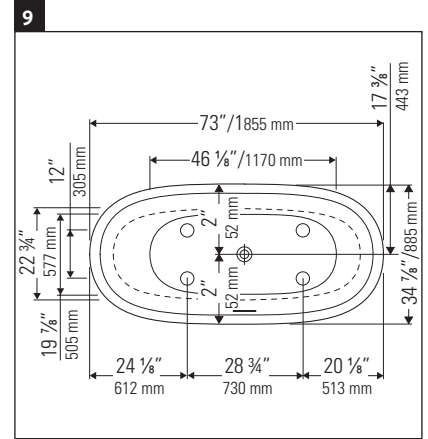

Measurements for Cape Cod.

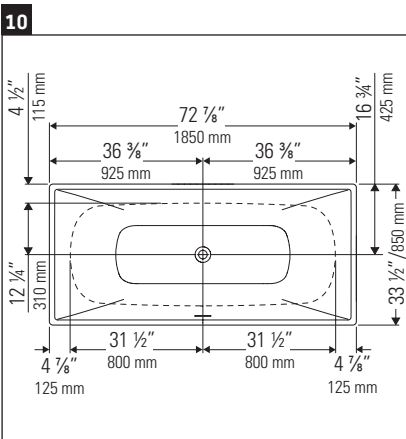

Measurements for DuraSquare.

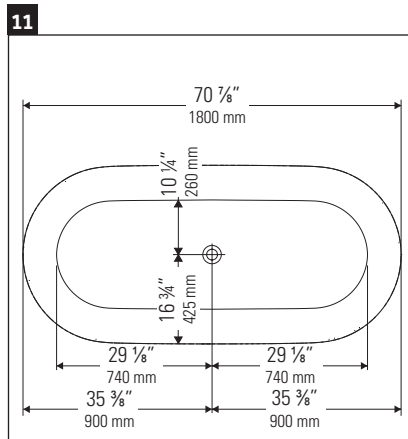

Measurements for Luv.

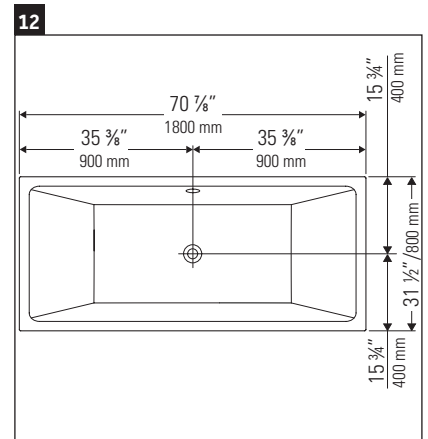

Measurements for Vero Air.

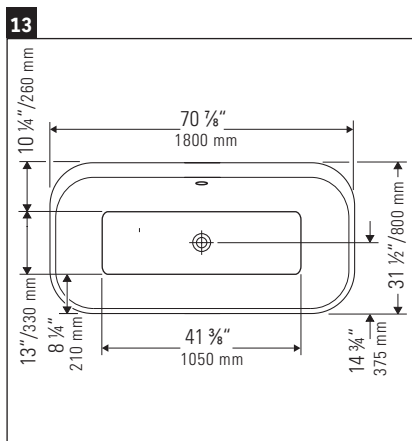

Measurements for Happy D.2 Plus.

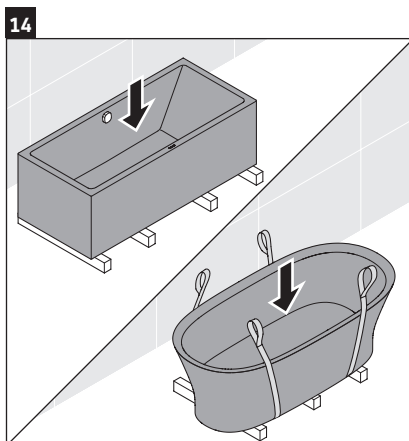

> Position bathtub.

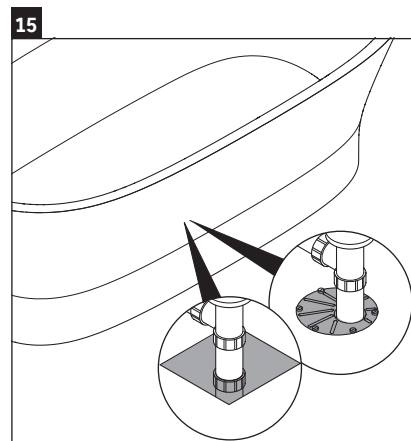

> Remove installation aids.
> Connect bathtub to drain system.

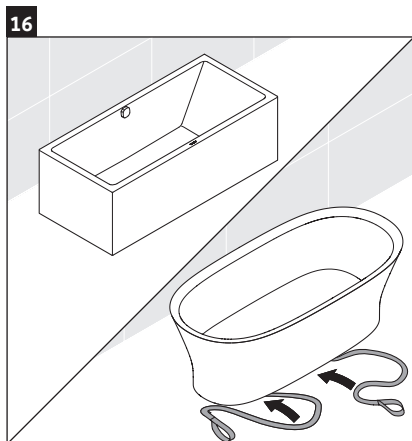

> Slide straps under the bathtub.

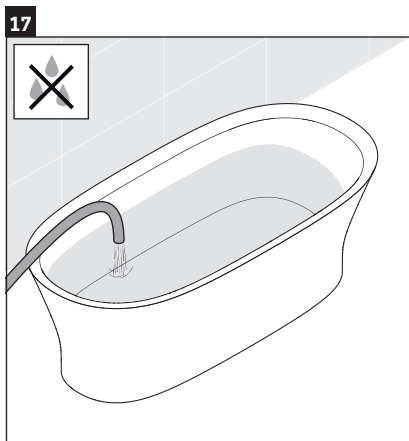

> Fill the bathtub with water.
> Inspect for potential leaks.
> Make sure to water test fittings.

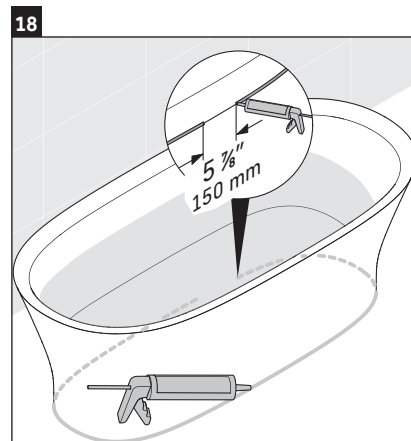

NOTICE

- > Apply silicone recommended for acrylic/mineral cast bathtubs only.
- > Apply 100% silicone sealant around the base of the bathtub.
- > Leave a small area open.



19

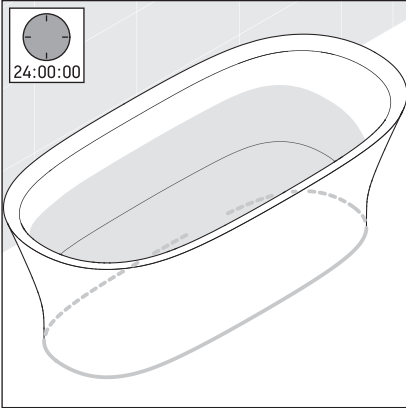

> Let it sit for 24 h before draining.

Concernant ces consignes

Les consignes de montage font partie intégrante du produit Duravit et doivent être lues attentivement avant le montage.

Groupe cible et qualification

Il s'agit ici d'un produit de niveau professionnel. Des connaissances pratiques des techniques de construction et des installations de plomberie conformes aux normes sont requises pour assurer une installation correcte et la satisfaction du client. Le produit doit être installé par un installateur sanitaire qualifié.

Explication des avertissements et symboles

ATTENTION

S'utilise pour répondre à des pratiques sans risques de blessures physiques.



Inspection (par ex. des rayures)



Vérifiez la présence de fuites et si tous les raccords sont étanches à l'eau



00:10:00

Indication de la durée (par ex. 10 minutes)

> Action requise

Instructions de sécurité

Dégâts matériels et/ou endommagement d'une caractéristique du produit

Le non-respect des réglementations et normes locales ou spécifiques à un pays peut entraîner des dégâts matériels et / ou d'une caractéristique du produit.

- > Les prescriptions d'installation des sociétés de distribution locales et les normes nationales doivent être respectées sans réserve.

Une manipulation négligente peut causer des dommages sur les surfaces des baignoires laquées.

- > Protégez la baignoire contre les chocs et les rayures durant l'installation et le transport.

Avant l'installation

Veillez lire les fiches de spécifications avant l'installation. Les fiches de spécifications peuvent être téléchargées sur www.pro.duravit.us.

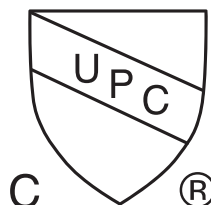

Les produits sont conformes aux codes suivants :

- Uniform Plumbing Code (UPC®)
- Code national de la plomberie du Canada



Contenu de la livraison

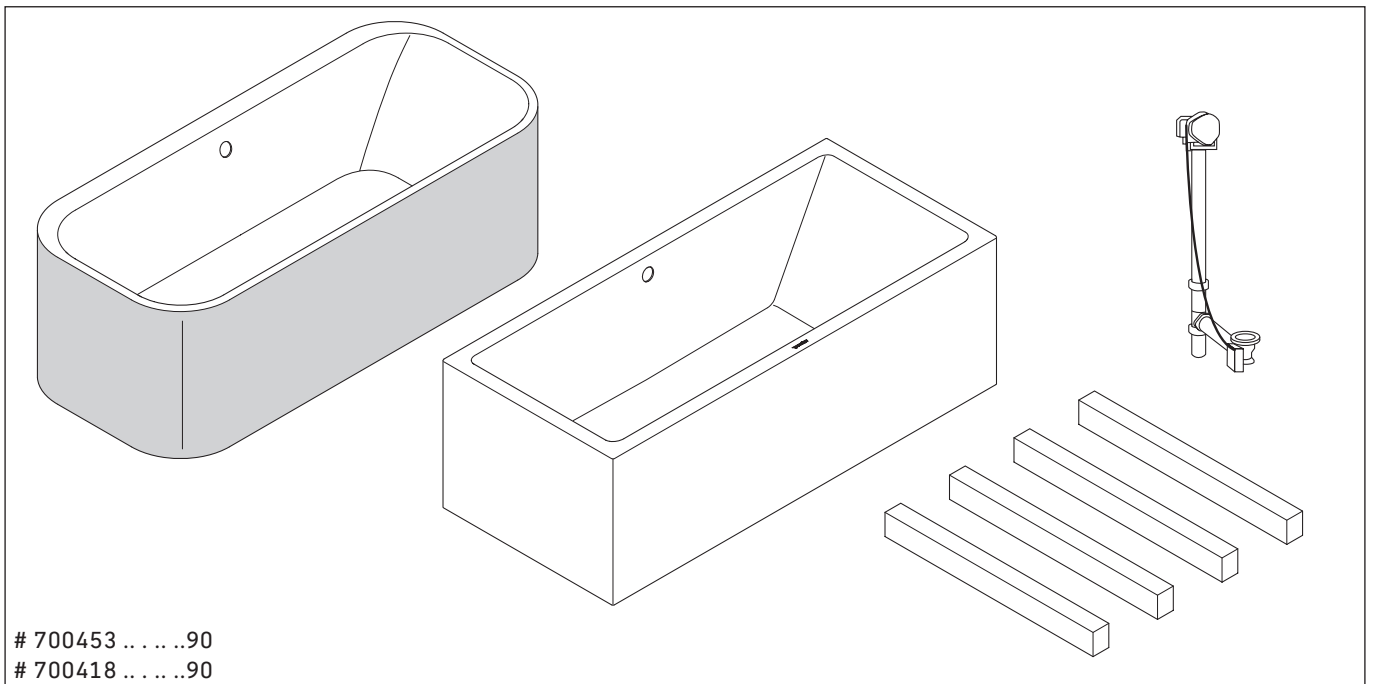
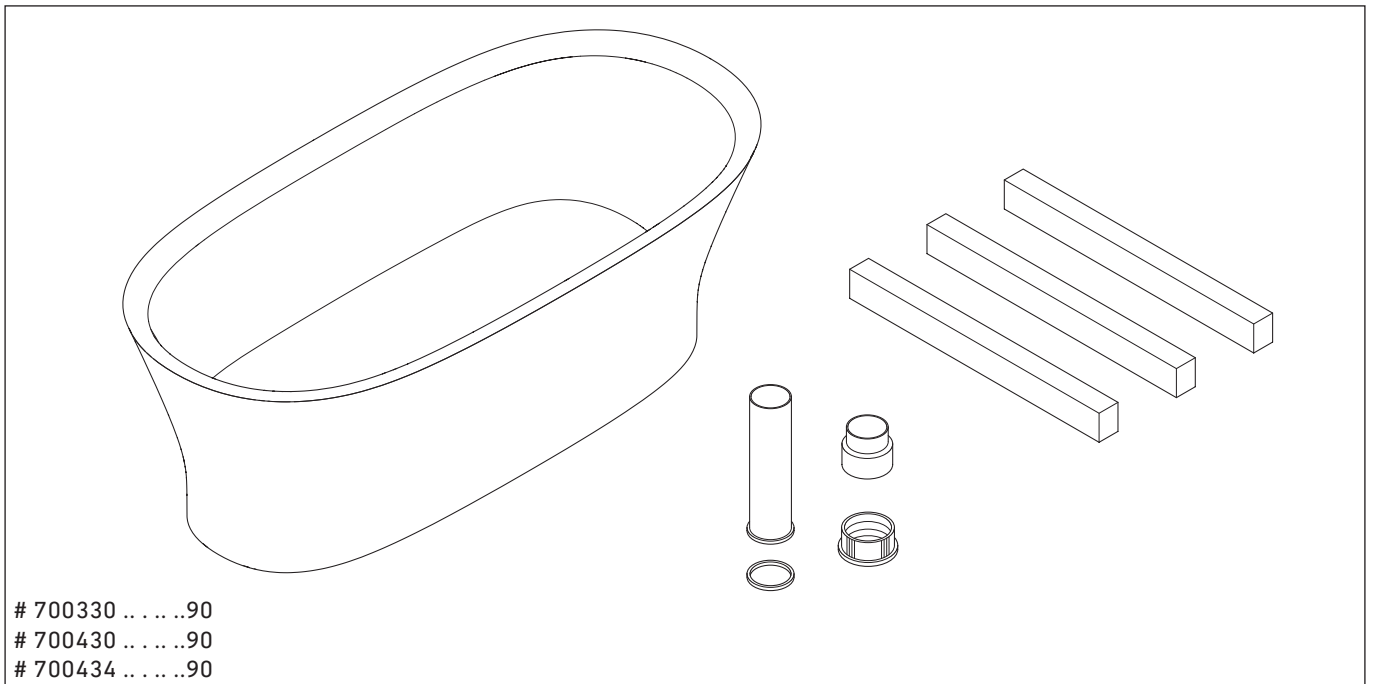

**Accessoires optionnels (non fournis)**

Drain dans le sol pour baignoire
autoportante

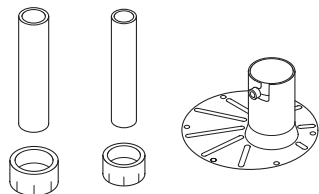

791281 (PVC)
791282 (ABS)

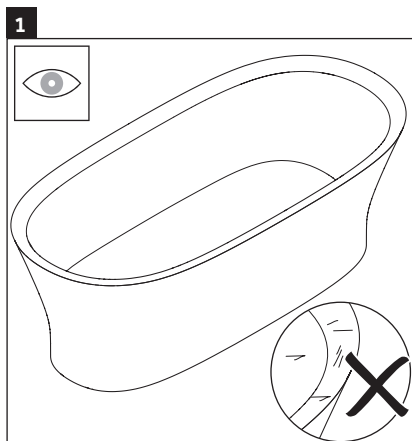

- > Vérifiez la présence sur la baignoire d'éventuels dommages pouvant être survenus durant le transport.
- > Ne pas installer si des dommages sont visibles.

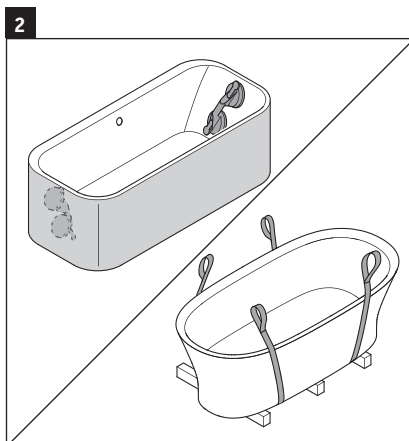

ATTENTION

Des élévateurs à ventouse peuvent causer des dommages sur les surfaces des baignoires laquées.

- > Fixer les élévateurs à ventouse à l'intérieur des baignoires laquées afin d'éviter les dommages sur les surfaces laquées.

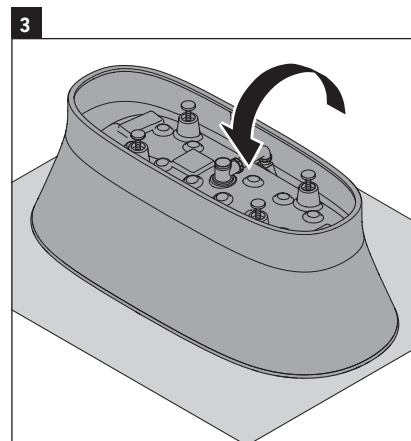

ATTENTION

Basculer la baignoire sur le côté peut l'endommager.

- > Posez du carton/une couverture sur le sol.
- > Retournez la baignoire.

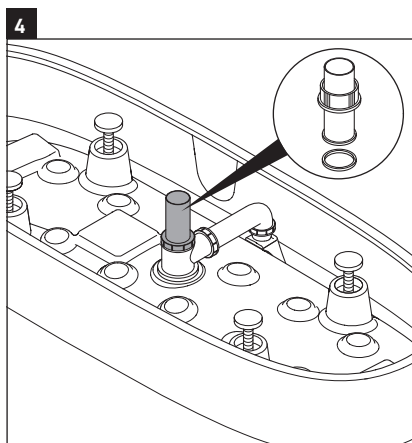

- > Raccordez la pièce de raccordement au drain de la baignoire.

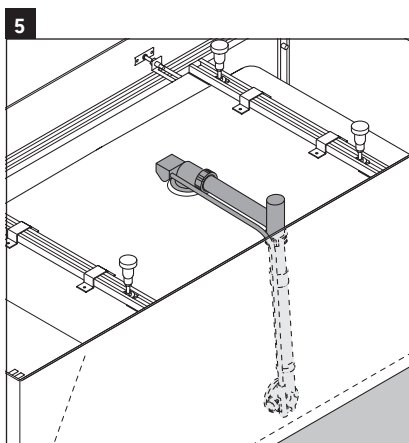

Pour Vero Air/Happy D.2 Plus :

- > Raccordez l'évacuation et le trop-plein.

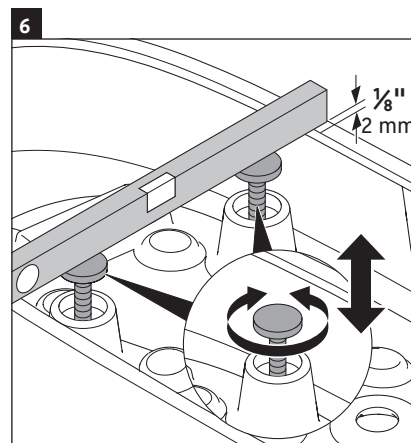

- > Nivelez les pieds avant de poser la baignoire.



fr

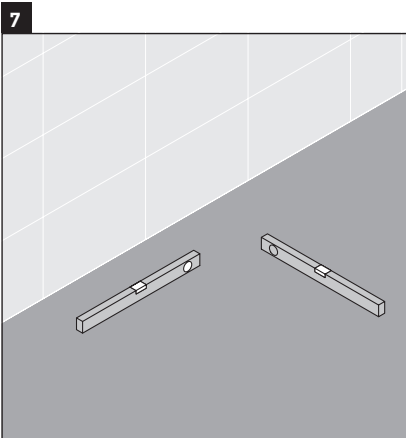

- > Assurez-vous que le sol est dégagé et à niveau.
- > Compensez les irrégularités en ajustant les pieds de la baignoire.

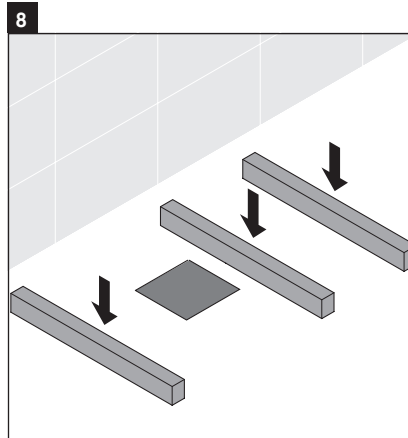

- > Respectez les dimensions des diagrammes 9 à 13 pour le positionnement du drain.
- > Positionnez les aides à l'installation en conséquence.

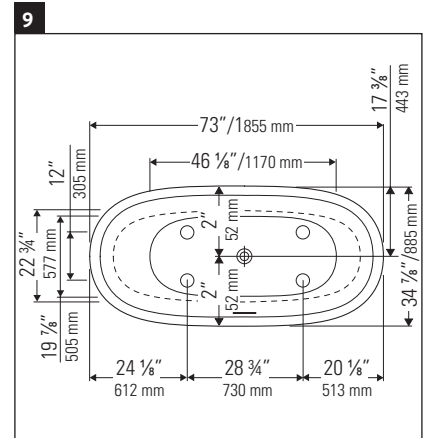

Dimensions pour Cape Cod.

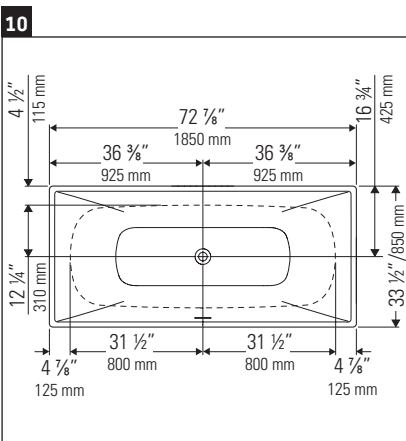

Dimensions pour DuraSquare.

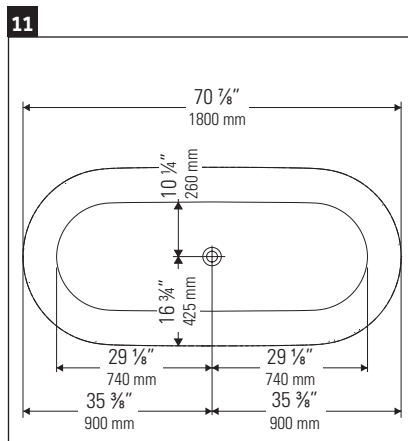

Dimensions pour Luv.

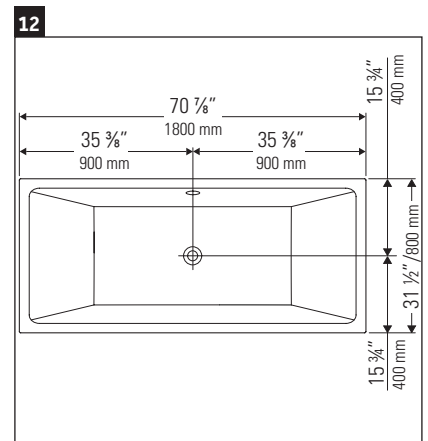

Dimensions pour Vero Air.

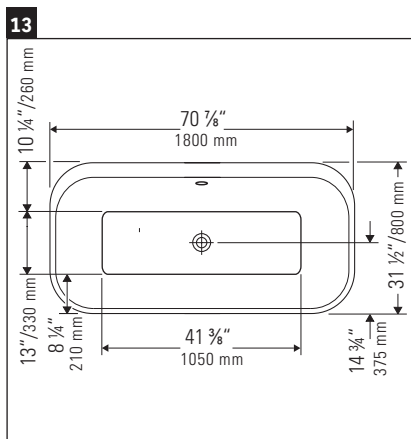

Dimensions pour Happy D.2 Plus.

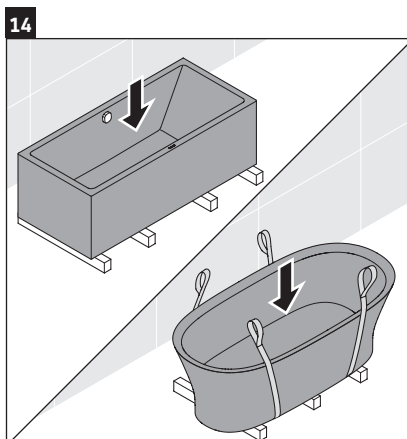

> Positionnez la baignoire.

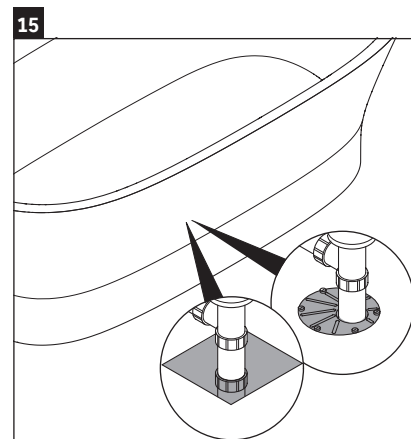

> Retirez les aides à l'installation.
> Raccordez la baignoire au système d'évacuation.

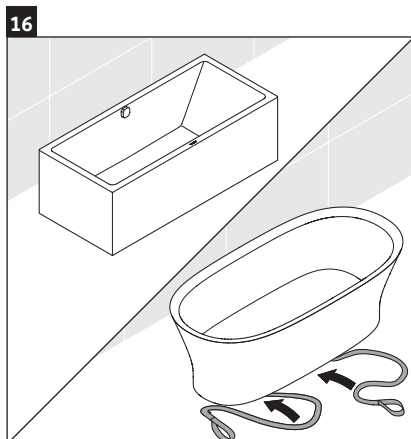

> Faites glisser les sangles sous la baignoire.

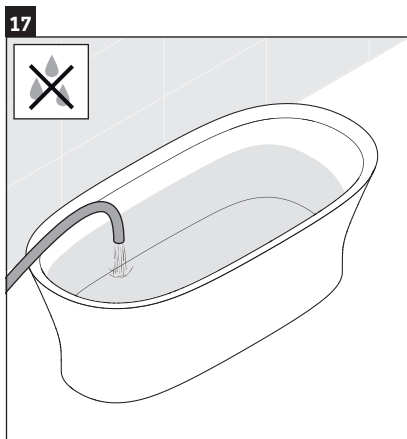

> Remplissez la baignoire d'eau.
> Vérifiez la présence d'éventuelles fuites.
> Veillez à vérifier l'étanchéité à l'eau des fixations.

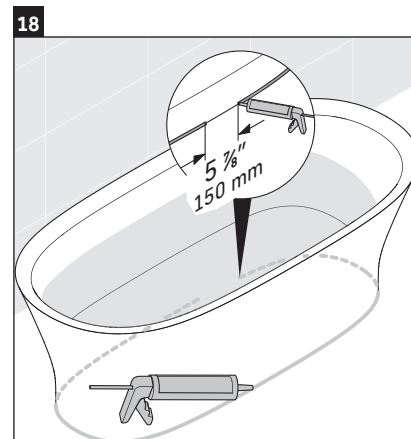

ATTENTION

> Appliquez uniquement le silicone recommandé pour les baignoires en acrylique/fonte minérale.
> Appliquez un scellant 100 % silicone sur le pourtour de la base de la baignoire.
> Laissez un petit espace ouvert.



19

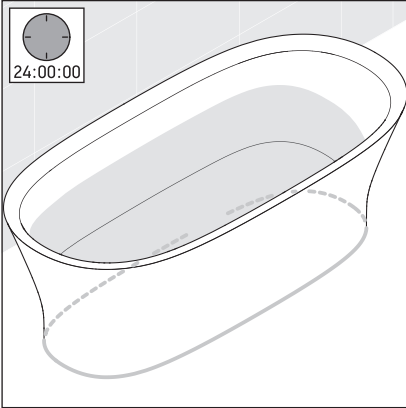

- > Laissez reposer pendant 24 h avant de vider.



Acerca de estas instrucciones

Las instrucciones de instalación son parte del producto Duravit y deben leerse con atención antes de la instalación.

Lectores destinatarios y cualificaciones

Este es un producto de calidad profesional. Para su correcta instalación y garantizar la satisfacción de los usuarios, se requieren conocimientos prácticos sobre técnicas de montaje así como cumplir la reglamentación de fontanería. La instalación del producto solo puede llevarse a cabo por un fontanero profesional.

Explicación de las palabras clave y de los símbolos

AVISO

Se utiliza para describir prácticas no relacionadas con lesiones físicas.



Inspección (p. ej. por si hubiera arañazos)



Comprobar que no haya fugas y que todas las conexiones sean estancas al agua



Indicación del tiempo (p. ej. 10 minutos)

> Se requiere una acción

Instrucciones de seguridad

Daños materiales y/o en el producto

El incumplimiento de las normas y reglamentos locales y específicos de cada país puede provocar daños materiales y/o en el producto.

> Observar en todo momento los reglamentos locales de instalación y las normas específicas de cada país.

Un manejo descuidado puede causar daños en la superficie de las bañeras lacadas.

> Proteja la bañera de los golpes y los arañazos durante la instalación y el transporte.

Antes de la instalación

Leer las fichas técnicas antes de la instalación. Las fichas técnicas pueden descargarse en www.pro.duravit.us.

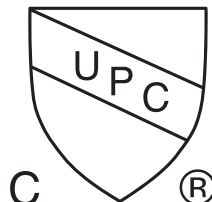

Los productos cumplen los siguientes códigos:

- Código de fontanería uniforme (UPC®)
- Código canadiense de fontanería



Contenido del suministro

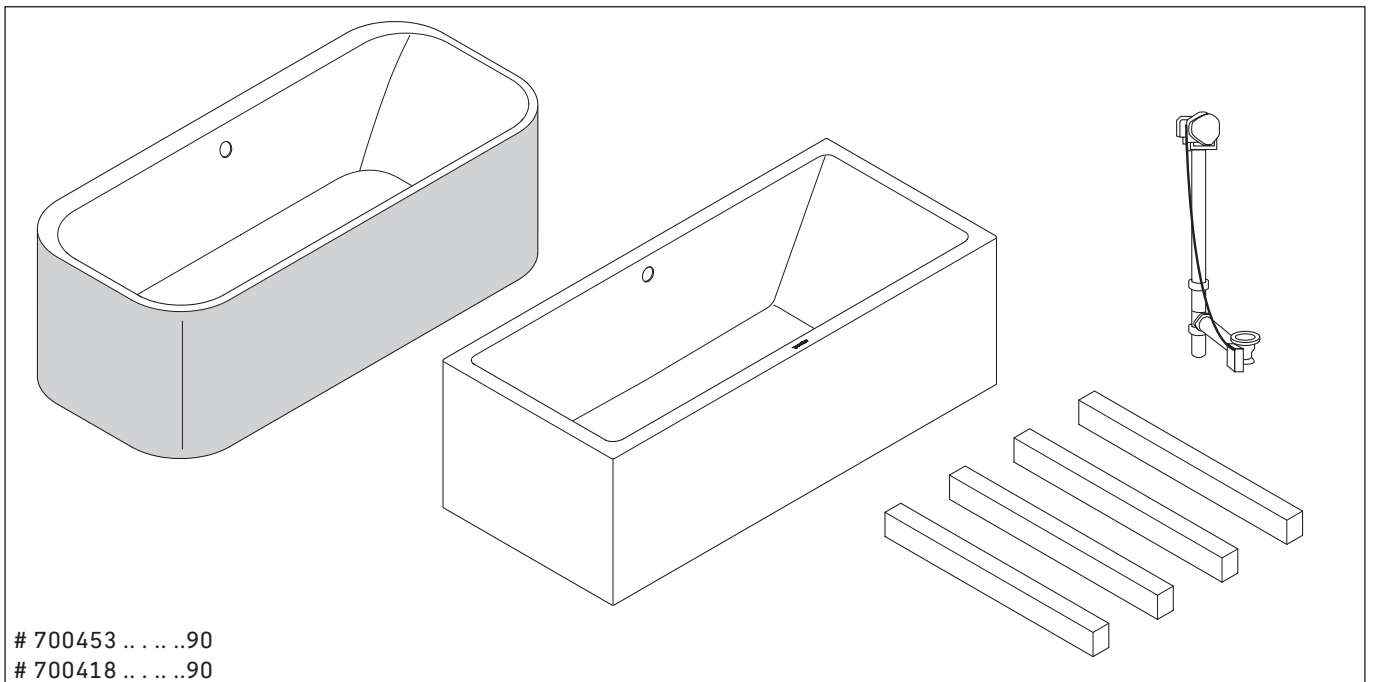
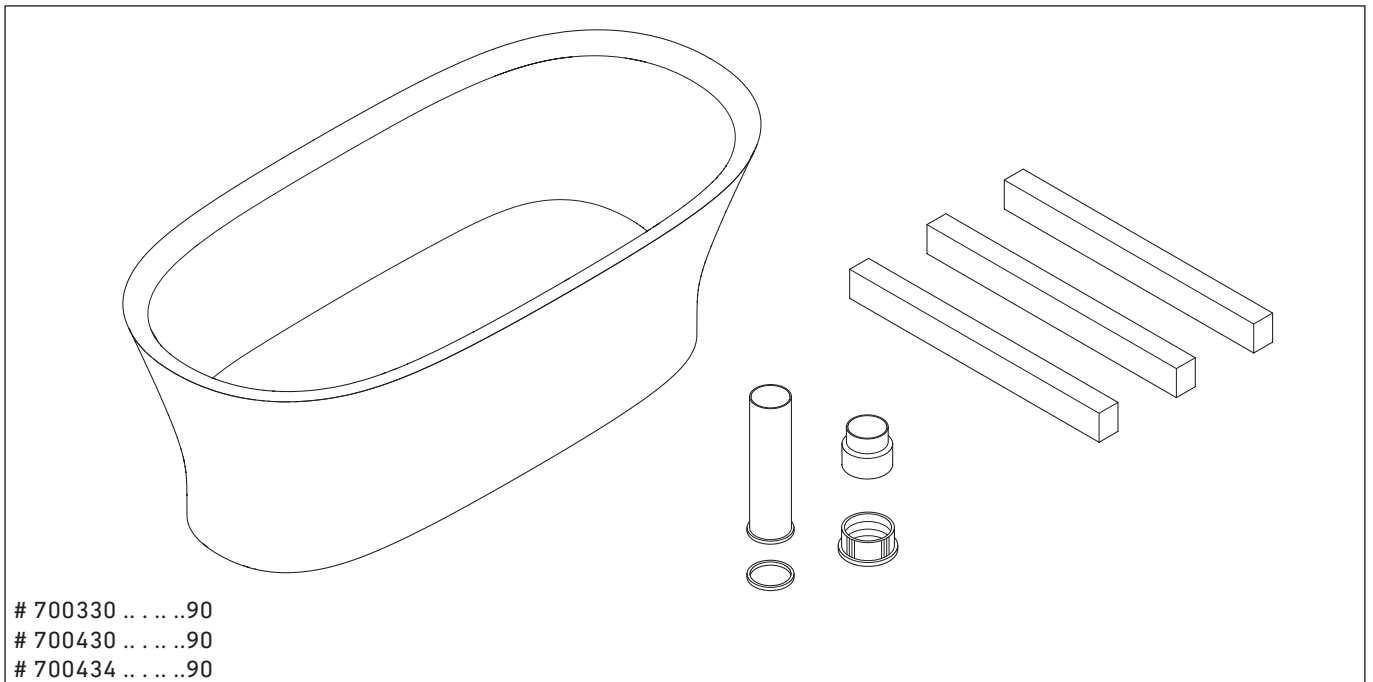

**Accesorios opcionales (no incluidos)**

Desagüe para bañera en suelo

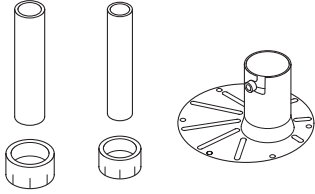

791281 (PVC)

791282 (ABS)

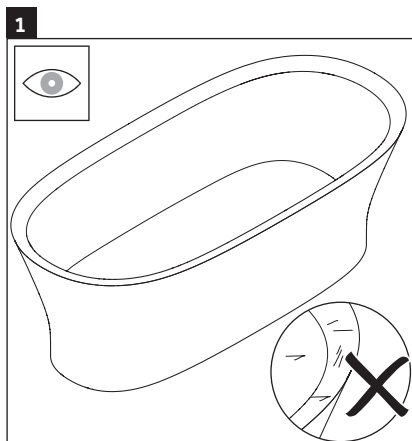

- > Inspeccionar la bañera por si hubiera ocurrido algún daño durante el transporte.
- > No instalar el producto si hay daños visibles.

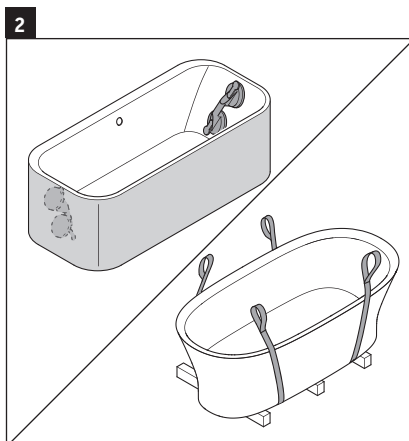

AVISO

- Los elevadores por succión pueden causar daños en la superficie de las bañeras lacadas.
- > Coloque los elevadores por succión en el interior de las bañeras lacadas para evitar que se dañe la superficie lacada.

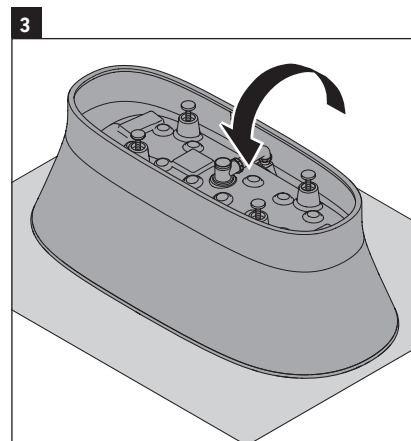

AVISO

- Si se inclina la bañera sobre uno de sus lados, se pueden producir daños en la misma.
- > Colocar un cartón o una manta sobre el suelo.
 - > Dar la vuelta a la bañera.

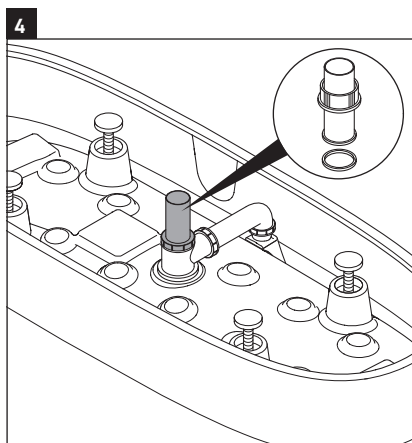

- > Conectar el empalme al desagüe de la bañera.

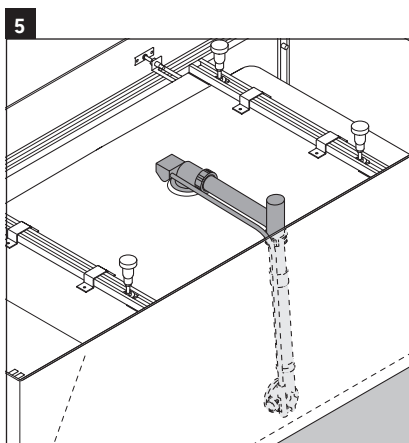

Para Vero Air/Happy D.2 Plus:

- > Conectar la tubería de residuos y el rebosadero.

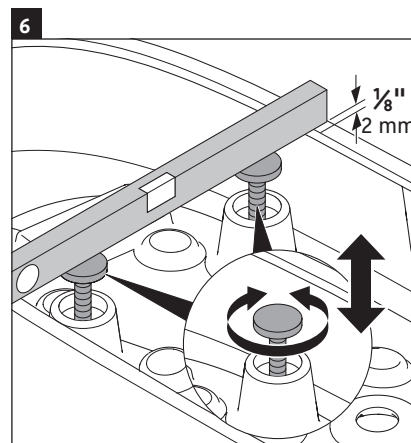

- > Nivelar las patas antes de ajustar la bañera.



es

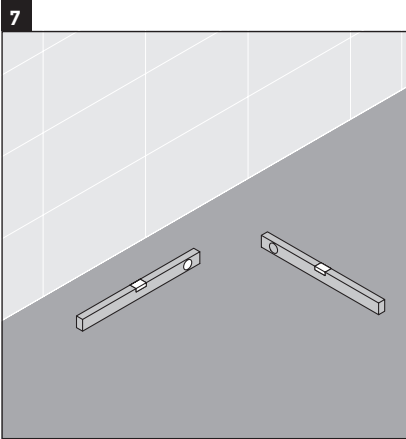

- > Asegurarse de que la zona del suelo esté limpia y nivelada.
- > En caso de irregularidades, compensarlas ajustando las patas de la bañera.

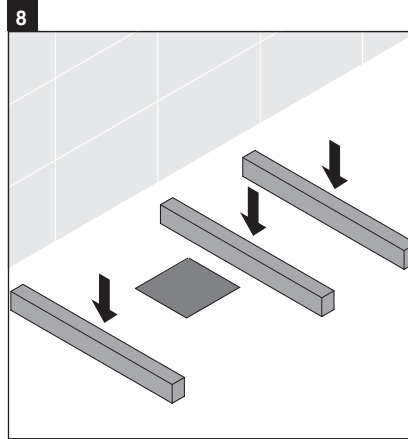

- > Para colocar el desagüe, observar las dimensiones en los diagramas 9 a 13.
- > Colocar las ayudas de instalación según corresponda.

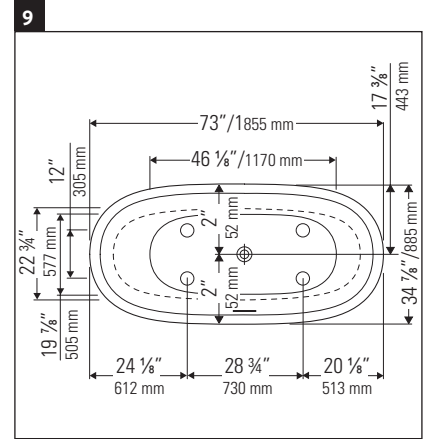

Medidas para Cape Cod.

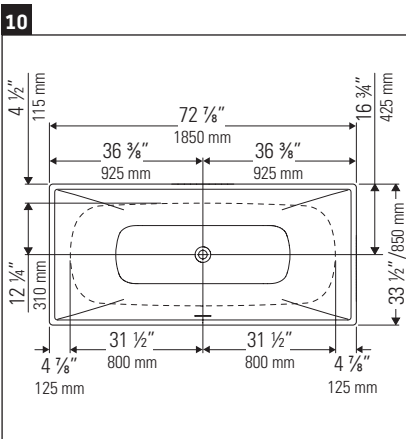

Medidas para DuraSquare.

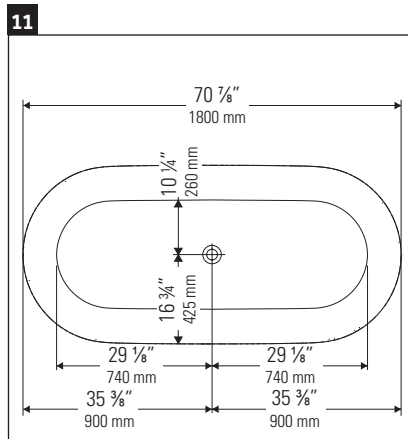

Medidas para Luv.

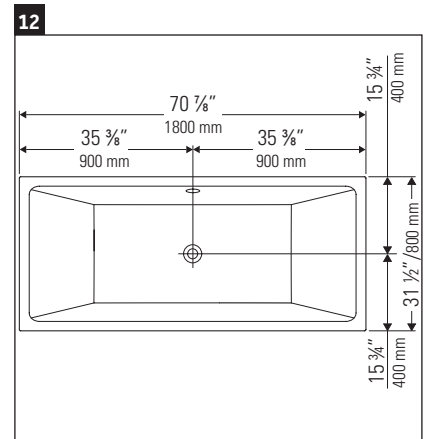

Medidas para Vero Air.

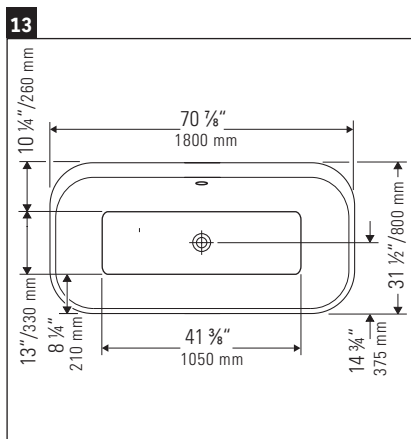

Medidas para Happy D.2 Plus.

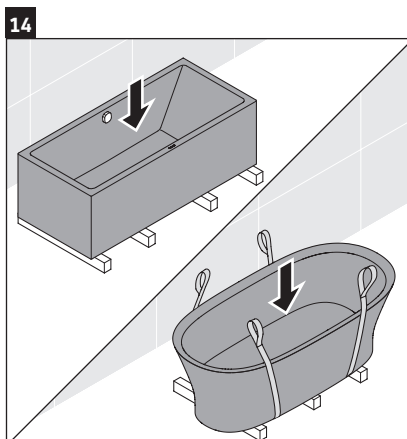

> Colocar la bañera.

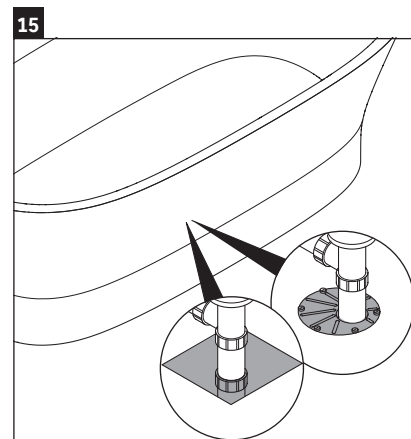

> Retirar las ayudas de instalación.
> Conectar la bañera al sistema de desagüe.

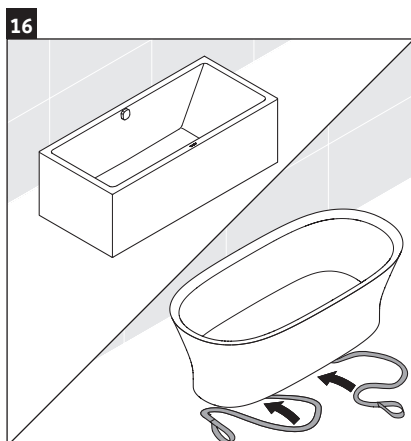

> Deslizar las correas por debajo de la bañera.

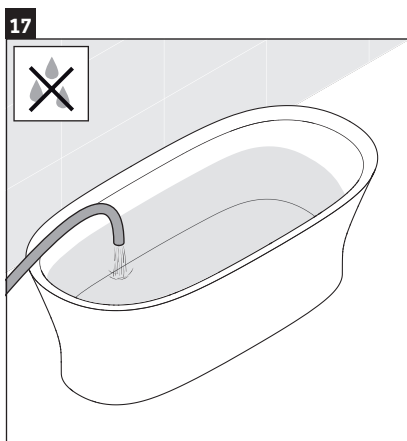

> Llenar con agua la bañera.
> Inspeccionar por si hubiera posibles fugas.
> Asegurarse de que los accesorios sean a prueba de agua.

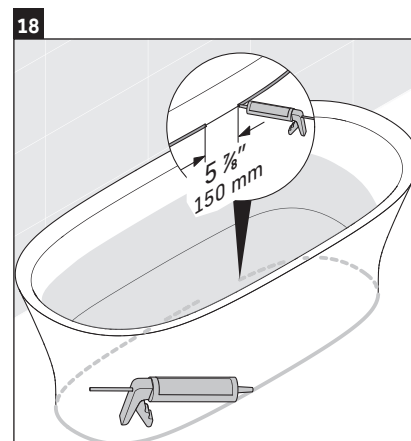

AVISO

- > Aplicar solamente silicona recomendada para bañeras acrílicas/ de material mineral.
- > Aplicar silicona al 100 % alrededor de la base de la bañera.
- > Dejar una pequeña zona abierta.



19

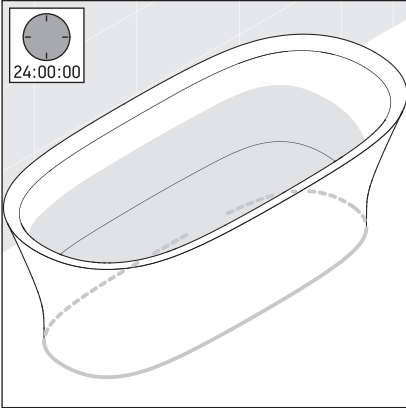

- > Dejar que la silicona se asiente durante 24 h antes de vaciar la bañera.

DURAVIT USA, INC.
2635 North Berkeley Lake Rd., Ste. 100
Duluth, GA 30096
Toll Free 888-DURAVIT
Phone 770-931-3575
Fax 770-931-8454
info@us.duravit.com
www.duravit.us

