

This file has been cleaned of potential threats.

If you confirm that the file is coming from a trusted source, you can send the following SHA-256 hash value to your admin for the original file.

81b9b123f0adf597fbb41b33b329dba062110609d6ffaed12d70689748deaaf9

To view the reconstructed contents, please SCROLL DOWN to next page.

**PRODUCT SPECIFICATIONS**

Elkay Crosstown® 16 Gauge Stainless Steel 35-7/8" x 20-1/4" x 9" Equal Double Bowl Tall Farmhouse Sink Kit with Aqua Divide. Sink is manufactured from 16 gauge 304 Stainless Steel with a Polished Satin finish, Rear Center drain placement, and Full spray sides and bottom with Sides and Bottom pads.

|                              |  |
|------------------------------|--|
| <b>Installation Type:</b>    | Farmhouse  |
| <b>Material:</b>             | 304 Stainless Steel                                    |
| <b>Special Features:</b>     | Aqua Divide  |
| <b>Finish:</b>               | Polished Satin   |
| <b>Gauge:</b>                | 16   |
| <b>Sound Deadening:</b>      | Full spray sides and bottom with Sides and Bottom pads |
| <b>Number of Bowls:</b>      | 2  |
| <b>Sink Dimensions:</b>      | 35-7/8" x 20-1/4" x 9"                                 |
| <b>Bowl 1 Dimensions:</b>    | 16-7/16" x 17" x 9"                                    |
| <b>Bowl 2 Dimensions:</b>    | 16-7/16" x 17" x 9"                                    |
| <b>Drain Size:</b>           | 3-1/2" (89mm)  |
| <b>Drain Location:</b>       | Rear Center  |
| <b>Minimum Cabinet Size:</b> | 36"  |
| <b>Mounting Hardware:</b>    | Part # 54300008 included                               |



**Included with Product:** EFRUFFA3417 sink, two CTXFBG1516 bottom grids, two LKDD deep strainer drains

AMERICAN PRIDE. A LIFETIME TRADITION. Like your family, the Elkay family has values and traditions that endure. For almost a century, Elkay has been a family-owned and operated company, providing thousands of jobs that support our families and communities.

**Product Compliance:** ASME A112.19.3/CSA B45.4

**Installation Profile:**

1/8" OVERHANG

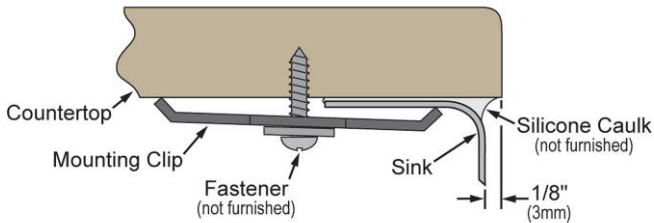

Designed to affix to the underside of any solid surface countertop.

**OPTIONAL ACCESSORIES**

|                  |                       |
|------------------|-----------------------|
| <b>Hardware:</b> | LKUCLIP8 (2 Required) |
|------------------|-----------------------|



Sinks are listed by IAPMO® as meeting the applicable requirements of the Uniform Plumbing Code®, International Plumbing Code®, and National Plumbing Code of Canada.

- [Clean and Care Manual \(PDF\)](#)
- [Installation Instructions \(PDF\)](#)
- [Warranty \(PDF\)](#)

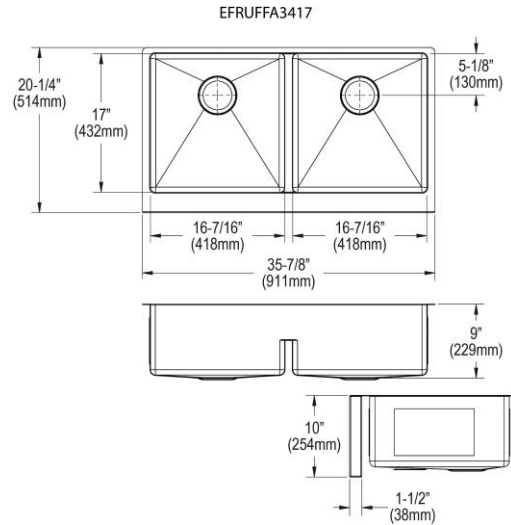

PART: \_\_\_\_\_ QTY: \_\_\_\_\_

PROJECT: \_\_\_\_\_

CONTACT: \_\_\_\_\_

DATE: \_\_\_\_\_

NOTES: \_\_\_\_\_

APPROVAL: \_\_\_\_\_

*In keeping with our policy of continuing product improvement, Elkay reserves the right to change product specifications without notice. Please visit elkay.com for the most current version of Elkay product specification sheets. This specification describes an Elkay product with design, quality, and functional benefits to the user. When making a comparison of other producers' offerings, be certain these features are not overlooked.*