

This file has been cleaned of potential threats.

If you confirm that the file is coming from a trusted source, you can send the following SHA-256 hash value to your admin for the original file.

005fe2684a577c9dcff939803e219f8a905d8aafa9551bf21c59b59650b54a68

To view the reconstructed contents, please SCROLL DOWN to next page.

PRODUCT SPECIFICATIONS

Elkay Fireclay 33" x 19-15/16" x 9-3/16" 60/40 Double Bowl Farmhouse Workstation Sink Kit with Aqua Divide, White. Sink is molded from fine fireclay with a durable porcelain glaze providing a finish that is non-porous and resists staining. Naturally sound deadening and Center drain placement.

Installation Type:	Farmhouse
Material:	Fireclay
Special Features:	Aqua Divide, Workstation
Finish:	White (WH)
Number of Bowls:	2
Sink Dimensions:	33" x 19-15/16" x 9-3/16"
Bowl 1 Dimensions:	12" x 16-1/4" x 9-1/8"
Bowl 2 Dimensions:	18-3/8" x 16-1/4" x 9-1/8"
Drain Size:	3-1/2" (89mm)
Drain Location:	Center
Minimum Cabinet Size:	36"
Mounting Hardware:	No
Cutout Template #:	NA

Template is available for download at elkay.com. CAD software will be required to open the template.

Special Note: Reserve Selection products available in store only. Sink is reversible offering the option of a traditional flat front or a decorative band feature.



Installation Profile:

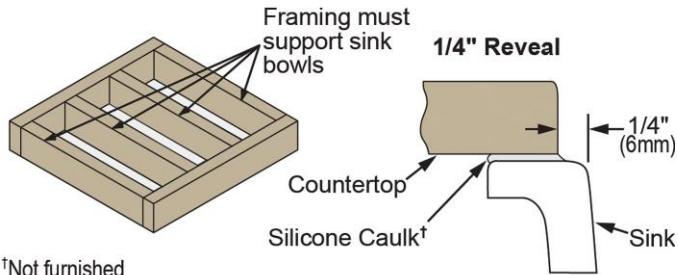

Designed to affix to the underside of any solid surface countertop.

PART: _____ QTY: _____

PROJECT: _____

CONTACT: _____

DATE: _____

NOTES: _____

APPROVAL: _____



Included with Product: SWUF3320WH sink, one LKCB1217HW cutting board, one LKBG1115SS bottom grid, one LKBG1715SS bottom grid, two LK99FC drains, and a LKCLKIT cleaning kit.

▼ Ships in multiple boxes.

AMERICAN PRIDE. A LIFETIME TRADITION.
Like your family, the Elkay family has values and traditions that endure. For almost a century, Elkay has been a family-owned and operated company, providing thousands of jobs that support our families and communities.

Product Compliance: ASME A112.19.2/CSA B45.1
Accessory: ASME A112.18.2/CSA B125.2

[Clean and Care Manual \(PDF\)](#)
[Installation Instructions \(PDF\)](#)
[Warranty \(PDF\)](#)

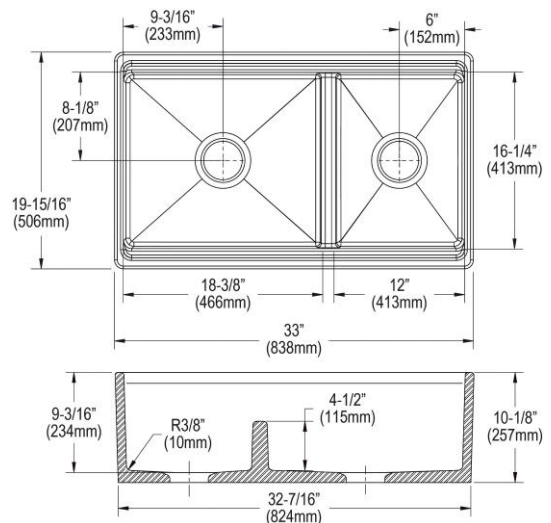

In keeping with our policy of continuing product improvement, Elkay reserves the right to change product specifications without notice. Please visit elkay.com for the most current version of Elkay product specification sheets. This specification describes an Elkay product with design, quality, and functional benefits to the user. When making a comparison of other producers' offerings, be certain these features are not overlooked.

OPTIONAL ACCESSORIES

Drain:	LK99FC
Faucet:	LKEC2037
Soap Dispenser:	LKGT1054

In keeping with our policy of continuing product improvement, Elkay reserves the right to change product specifications without notice. Please visit elkay.com for the most current version of Elkay product specification sheets. This specification describes an Elkay product with design, quality, and functional benefits to the user. When making a comparison of other producers' offerings, be certain these features are not overlooked.