

PRODUCT SPECIFICATIONS

Elkay ezH2O[®] Liv™ Built-in Filtered Water Dispenser, Remote Chiller. Chilling Capacity of 1.5 GPH (gallons per hour) of 50° F drinking water, based on 80° F inlet water and 90° F ambient, per ASHRAE 18 testing. Features shall include Chilled Water, Hands Free, Visual Filter Monitor, Automatic Filter Status Reset, Filtered, Green Ticker™, Laminar Flow. Electronic Bottle Filler Sensor activation. Product shall be Built-in, for Indoor applications, serving 1 station(s). Unit shall be certified to UL 399 and CAN/CSA C22.2 No. 120. Unit shall be lead-free design which is certified to NSF/ANSI 61 & 372 (lead free) and meets Federal and State low-lead requirements.

Special Features:	Chilled Water, Hands Free, Visual Filter Monitor, Automatic Filter Status Reset, Filtered, Green Ticker™, Laminar Flow
Finish:	Aspen White (WH), Midnight (BK)
Power:	115V/60Hz
Activation by:	Electronic Bottle Filler Sensor
Mounting Type:	Built-in
Chilling Capacity*:	1.5 GPH
Rated Watts:	165
Dimensions (L x W x H):	5-1/8" x 18" x 20-1/2"
Approx. Shipping Weight:	78 lbs.
Installation Location:	Indoor
No. of Stations Served:	1
*Based on 80° F inlet water & 90° F ambient air temp for 50° F chilled drinking water.	

- Visual Filter Monitor: LED Filter Status Indicator for when filter change is necessary.
- Filter is certified to NSF 42 and 53 for lead, particulate, chlorine, taste and odor reduction. 750 gal. capacity.
- Green Ticker: Informs user of number of 16.9 oz. plastic water bottles saved from waste.
- Laminar flow provides clean fill with minimal splash.

COOLING SYSTEM

- Compressor: Hermetically-sealed, reciprocating type, single phase. Sealed-in lifetime lubrication.
- Condenser: Fan cooled, copper tube with aluminum fins. Fan motor is permanently lubricated.
- Refrigerant Control: Refrigerant R-134a is controlled by accurately calibrated capillary tube.
- Temperature Control: Easily accessible enclosed adjustable thermostat is factory preset. Requires no adjustment other than for altitude requirements.

PART: _____ QTY: _____

PROJECT: _____

CONTACT: _____

DATE: _____

NOTES: _____

APPROVAL: _____



AMERICAN PRIDE. A LIFETIME TRADITION. Like your family, the Elkay family has values and traditions that endure. For almost a century, Elkay has been a family-owned and operated company, providing thousands of jobs that support our families and communities.



Included with Product: Water Dispenser, 1.5 GPH Water Chiller, Remote Filter Cable, 750 Gal Filter

PRODUCT COMPLIANCE

- ADA & ICC A117.1
- Buy American Act
- CAN/CSA C22.2 No. 120
- NSF/ANSI 42, 53, 61, & 372 (lead free)
- UL 399



Complies with ADA & ICC A117.1 accessibility requirements when installed according to the requirements outlined in these standards. Installation may require additional components and/or construction features to be fully compliant. Consult the local Authority Having Jurisdiction if necessary.

[Installation Instructions \(PDF\)](#)

Electrical components and water system are warranted for 12 months from date of installation. **Warranty pertains to drinking water applications only. Non-drinking water applications are not covered under warranty.**

[Warranty \(PDF\)](#)

In keeping with our policy of continuing product improvement, Elkay reserves the right to change product specifications without notice. Please visit elkay.com for the most current version of Elkay product specification sheets. This specification describes an Elkay product with design, quality, and functional benefits to the user. When making a comparison of other producers' offerings, be certain these features are not overlooked.

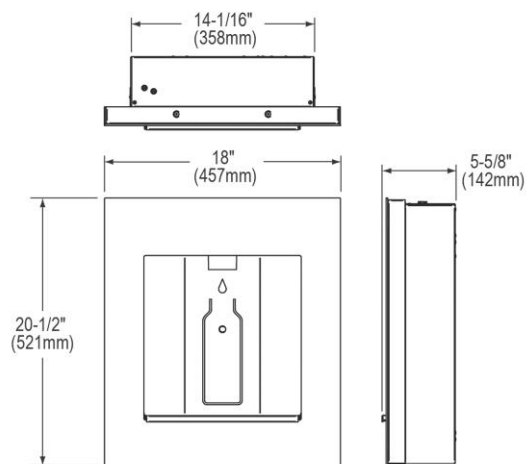

OPTIONAL ACCESSORIES

ERF750 - Elkay WaterSentry Plus Residential Replacement Filter
--

AP99 - Elkay Access Panel 9" x 9" x 6"
--

In keeping with our policy of continuing product improvement, Elkay reserves the right to change product specifications without notice. Please visit elkay.com for the most current version of Elkay product specification sheets. This specification describes an Elkay product with design, quality, and functional benefits to the user. When making a comparison of other producers' offerings, be certain these features are not overlooked.

**IMPORTANT!
INSTALLER PLEASE NOTE :**

This water cooler has been designed and built to provide water to the user which has not been altered by materials in the cooler waterways. The grounding of electrical equipment such as telephone, computer, etc. to water lines is a common procedure. The grounding may be in the building but may also occur away from the building. This grounding can cause electrical feedback into a water cooler creating an electrolysis which creates a metallic taste or causes an increase in the metal content of the water. This condition is avoidable by installing the cooler using the proper materials as shown below.

NOTICE

This built in water dispenser must be connected to the water supply using a dielectric coupling. The filter is furnished with a non-metallic ball valve which meets this requirement. The drain trap which is provided by the installer should also be plastic to completely isolate the cooler from the building plumbing system.

These products are designed to operate on 40 psi to 105 psi supply line pressure.

OPERATION OF QUICK CONNECT FITTINGS

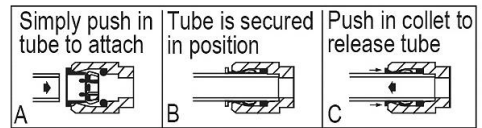

Pushing tube in before pulling it out helps to release tube

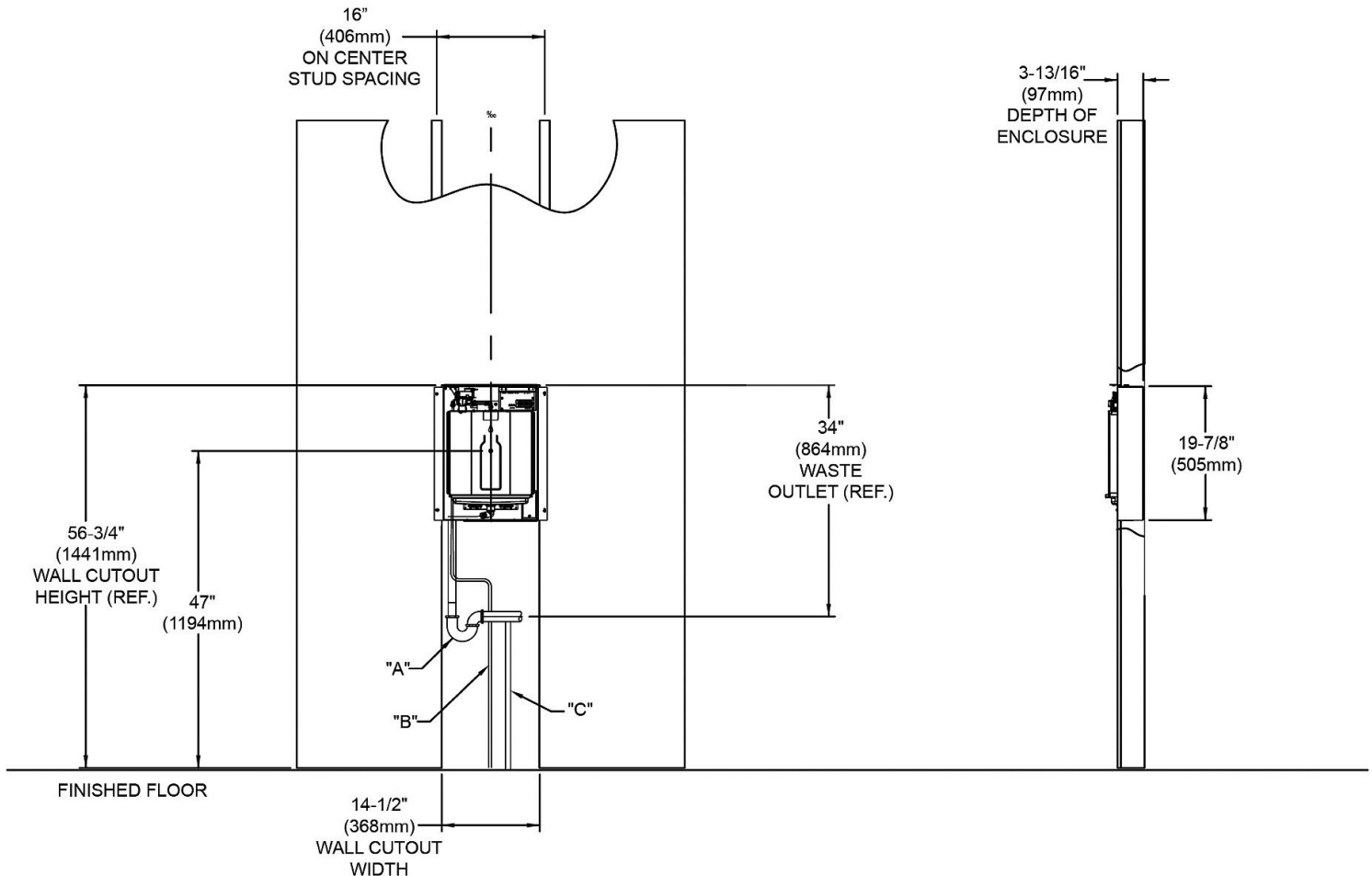

LEGEND:

A = Recommended location for waste outlet (optional), 1-1/4" (32mm) trap not furnished.

B = Recommended location for 1/4" (6.35mm) water inlet, to connect from chiller.

C = Recommended location for electrical supply. It is recommended that the supply be on dedicated 15a Hospital Grade GFCI breaker.

In keeping with our policy of continuing product improvement, Elkay reserves the right to change product specifications without notice. Please visit elkay.com for the most current version of Elkay product specification sheets. This specification describes an Elkay product with design, quality, and functional benefits to the user. When making a comparison of other producers' offerings, be certain these features are not overlooked.

Operating Pressures:

Supply water - recommended water pressure range is 40-105 psi

NOTE: A service stop (not included) should be installed at the chiller inlet line.

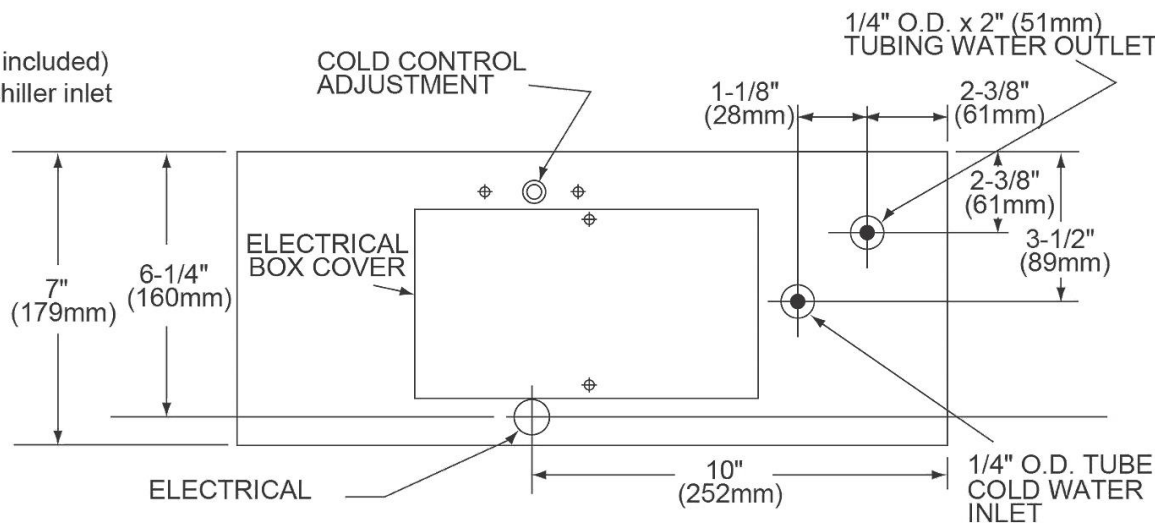

TOP VIEW

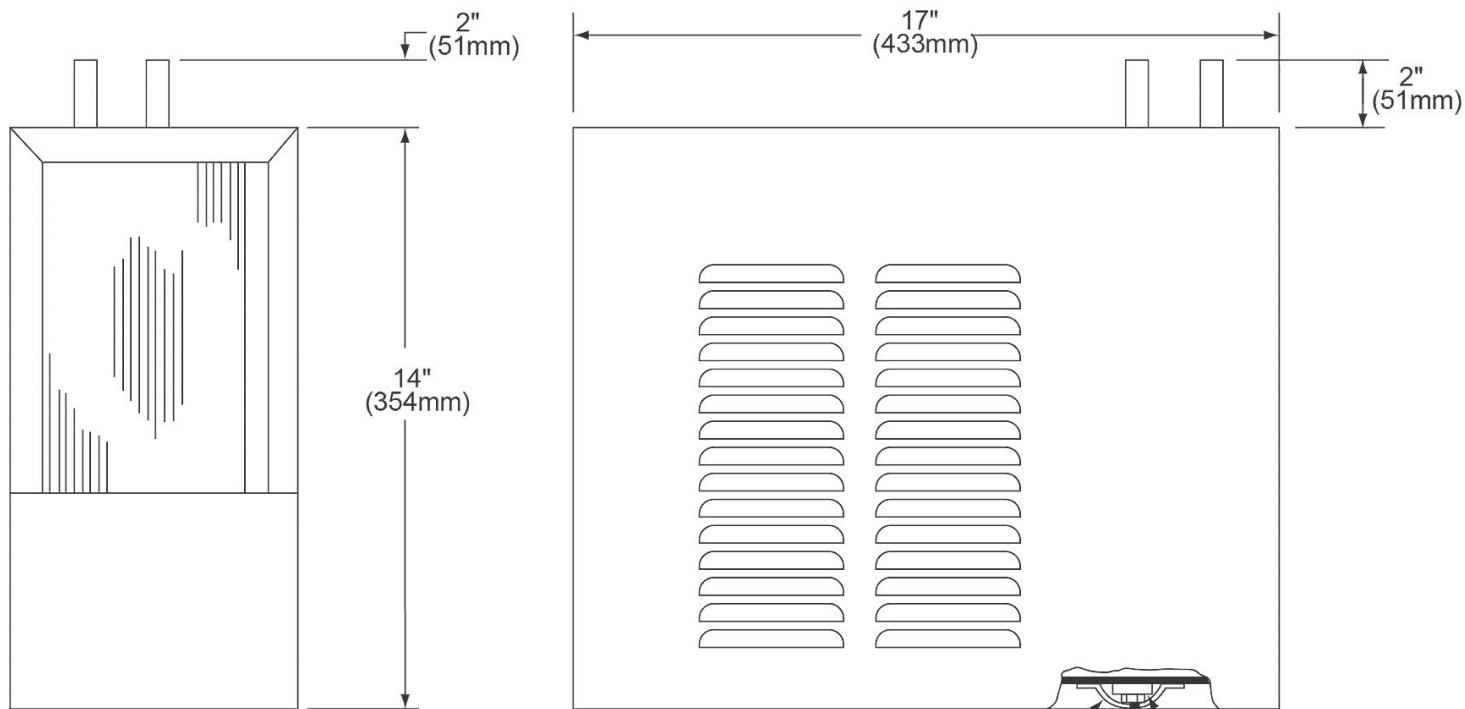

FRONT VIEW

SIDE VIEW

NOTE: It is important to insure proper ventilation. If this remote chiller is physically placed against barrier or in enclosure of any kind, 4" (102mm) air space must be allowed on all sides.

In keeping with our policy of continuing product improvement, Elkay reserves the right to change product specifications without notice. Please visit elkay.com for the most current version of Elkay product specification sheets. This specification describes an Elkay product with design, quality, and functional benefits to the user. When making a comparison of other producers' offerings, be certain these features are not overlooked.