

This file has been cleaned of potential threats.

If you confirm that the file is coming from a trusted source, you can send the following SHA-256 hash value to your admin for the original file.

2018cae926bf0b610b78779e917edef44c3fbb48d5aba36c0a36c0892cbb5e65

To view the reconstructed contents, please SCROLL DOWN to next page.

**PRODUCT SPECIFICATIONS**

Elkay 1-1/2" Drain Fitting Chrome Plated Brass with, Rubber Stopper Ring and Chain. Overall dimensions are 2-1/8" x 2-1/8" x 8-1/2". Made of Brass.

<b>Material:</b>	Brass
<b>Finish:</b>	Chrome (CR)
<b>Dimensions:</b>	2-1/8" x 2-1/8" x 8-1/2"
<b>Shipping Weight:</b>	1 lbs.

**Special Note:** Arranged for overflow

- 1-1/4" O.D. x 6" chrome plated brass tailpiece.



**AMERICAN PRIDE. A LIFETIME TRADITION.**  
Like your family, the Elkay family has values and traditions that endure. For almost a century, Elkay has been a family-owned and operated company, providing thousands of jobs that support our families and communities.

**Product Compliance:** ASME A112.18.2/CSA B125.2

[Clean and Care Manual \(PDF\)](#)  
[Installation Instructions \(PDF\)](#)

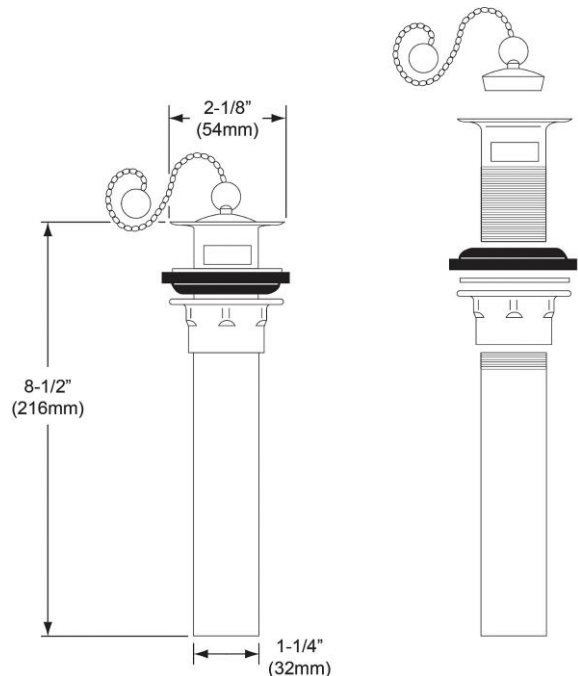

PART: \_\_\_\_\_ QTY: \_\_\_\_\_  
 PROJECT: \_\_\_\_\_  
 CONTACT: \_\_\_\_\_  
 DATE: \_\_\_\_\_  
 NOTES: \_\_\_\_\_  
 APPROVAL: \_\_\_\_\_

*In keeping with our policy of continuing product improvement, Elkay reserves the right to change product specifications without notice. Please visit [elkay.com](http://elkay.com) for the most current version of Elkay product specification sheets. This specification describes an Elkay product with design, quality, and functional benefits to the user. When making a comparison of other producers' offerings, be certain these features are not overlooked.*