



by/par **MAAX**

INSTALLATION INSTRUCTIONS GUIDE D'INSTALLATION GUÍA DE INSTALACIÓN

TUB SHOWER INSTALLATION (3 WALLS) INSTALLATION BAIGNOIRE DOUCHE (3 MURS) INSTALACIÓN DE BAÑERA DUCHA (3 MUROS)



View Installation Video - Scan QR code with a mobile device



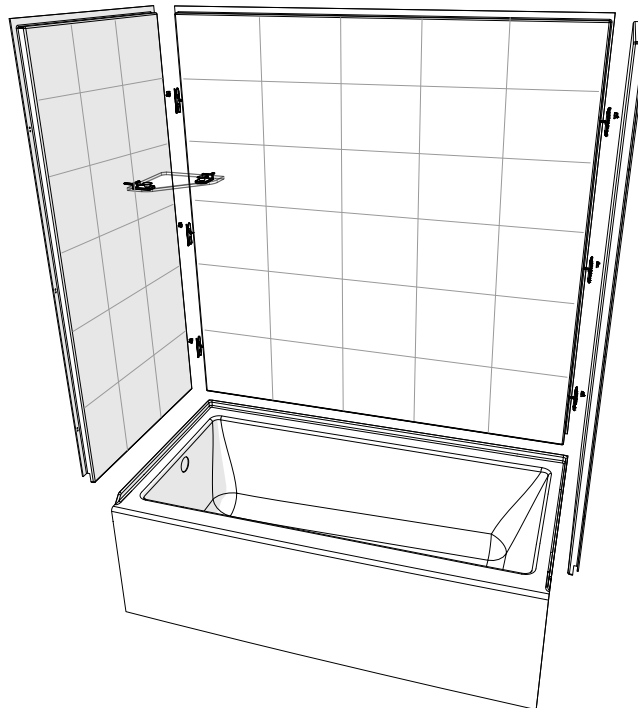

Voir Vidéo d'installation - Balayer QR code avec un dispositif mobile

**HARDWARE INCLUDED
IN BOXES**

**QUINCAILLERIE INCLUSE
DANS LES BOÎTES**

**ACCESORIOS INCLUIDOS
EN LAS CAJAS**

**OPEN ALL BOXES
BEFORE YOU START**

**OUVREZ TOUTES LES
BOÎTES AVANT DE
COMMENCER**

**ABRIR TODAS LAS CAJAS
ANTES DE EMPEZAR**



A two person installation is required.

Une installation par deux personnes est requise.

Se recomienda realizar la instalación entre dos personas

Read all instructions carefully before proceeding.
SAVE THIS GUIDE FOR FUTURE REFERENCE.

Lire toutes les instructions attentivement avant de commencer l'installation.
CONSERVER POUR UN USAGE ULTÉRIEUR.

Leer detenidamente todas las instrucciones antes de comenzar la instalación
CONSERVAR ESTE MANUAL COMO REFERENCIA.

IMPORTANT • Record the serial numbers
IMPORTANT • Noter les numéros de série
IMPORTANTE • Registre el número de serie

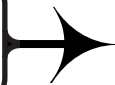

Serial numbers • Numéros de série • Números de serie

For installation steps in **ENGLISH** go to page 6

Table of contents:	Page
Tools and supplies.....	3
Parts and components.....	4
1. Building the structure.....	6
2. Installing the bathtub.....	7
3. Installing Ulok system on the walls.....	9
4. Temporary installation of the back wall.....	10
5. Temporary installation of the side walls.....	11
6. Final installation of back wall.....	14
7. Final installation of side walls.....	15
8. Marking and drilling the glass shelf holes.....	16
9. Silicone.....	17
10. Glass shelf installation.....	17
11. Wall finish / Maintenance tips.....	19
12. Warranty.....	48

Pour les étapes d'installation en **FRANÇAIS** aller à la page 20

Table de matières:	Page
Outils et matériaux.....	3
Pièces et composants.....	4
1. Construction de la structure.....	20
2. Installation de la baignoire.....	21
3. Installation du système Ulok sur les murs.....	23
4. Installation temporaire du mur arrière.....	24
5. Installation temporaire des murs de côté.....	25
6. Installation finale du mur arrière.....	28
7. Installation finale des murs de côté.....	29
8. Marquage et perçage des trous pour la tablette.....	30
9. Silicone.....	31
10. Installation de la tablette.....	31
11. Finition du mur / Conseils d'entretien.....	33
12. Garantie.....	48

Para las etapas en **ESPAÑOL** ir a la pagina 34

Tabla de contenido:	Página
Herramientas y materiales.....	3
Piezas y componentes.....	4
1. Construcción de la estructura.....	34
2. Instalación de la bañera.....	35
3. Instalación del sistema Ulok sobre los muros.....	37
4. Instalación temporal del muro posterior.....	38
5. Instalación temporal de los muros laterales.....	39
6. Instalación final del muro posterior.....	42
7. Instalación final de los muros laterales.....	43
8. Marcado y perforación de agujeros para la repisa.....	44
9. Silicona.....	45
10. Instalación de la repisa.....	45
11. Acabado del muro / Consejos de mantenimiento.....	47
12. Garantía.....	48

TOOLS | OUTILS | HERRAMIENTAS
REQUIRED | REQUIS | NECESARIAS

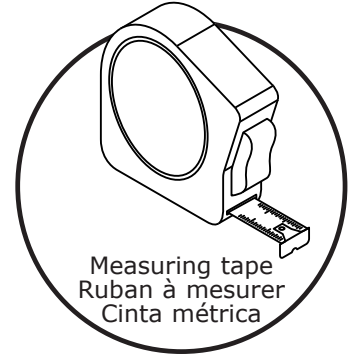
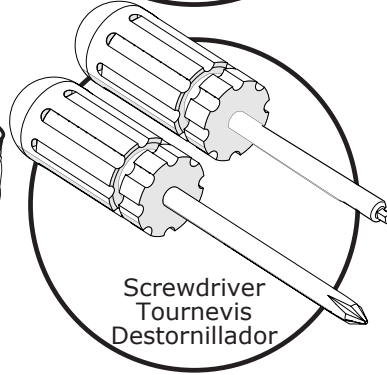
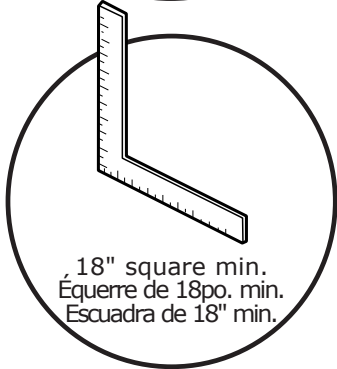
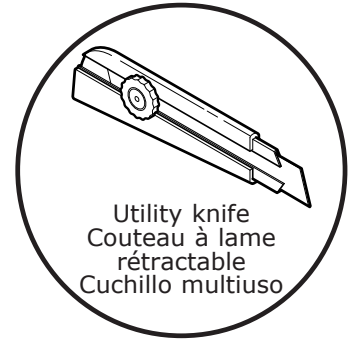
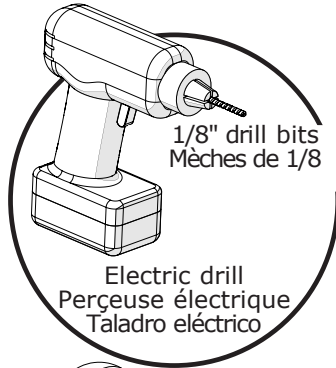
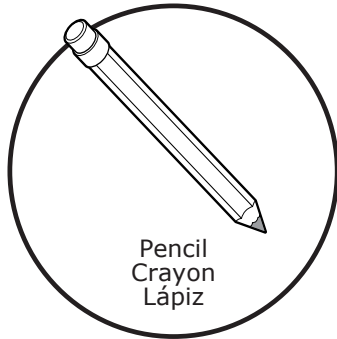
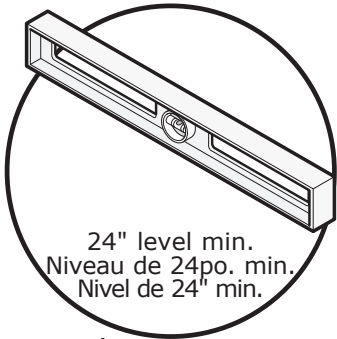

SUPPLIES | MATÉRIAUX | MATERIALES
SOLD SEPARATELY | VENDUS SÉPARÉMENT | VENDIDOS POR SEPARADO

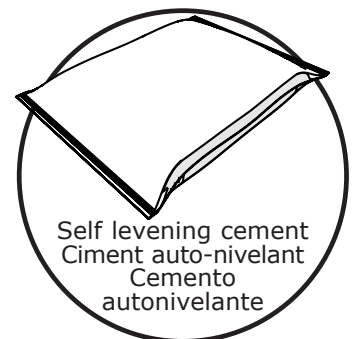
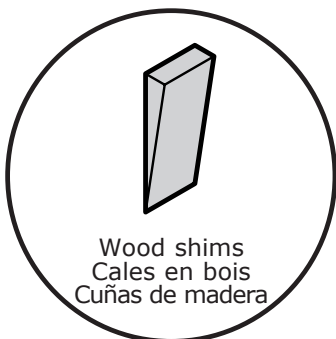

PARTS | PIÈCES | PIEZAS

Inside the box
À l'intérieur de la boîte
En el interior de la caja



PARTS INCLUDED IN PARTS PACK | PIÈCES COMPRISSES DANS L'EMBALLAGE DES PIÈCES
| PIEZAS INCLUIDAS EN PAQUETE DE PIEZAS

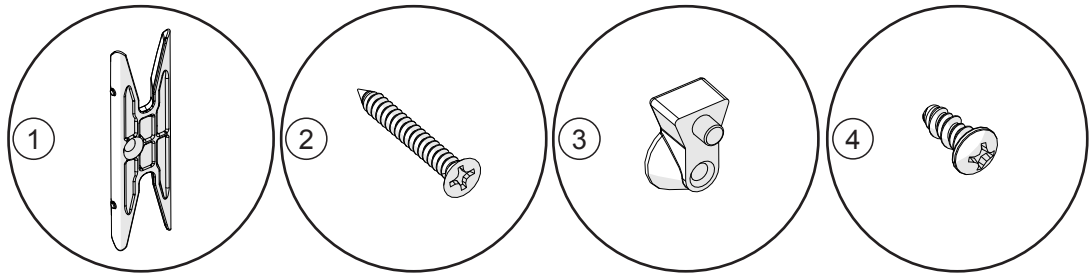

#	Part	Nom de la pièce	Pieza	Qty/Qté	Code
1	X fastener	Fixation en forme de X	Sujetador en forma de X	4	10060303
2	#8 x 1/4" Screw (for X fastener)	Vis #8 x 1/4" (Pour fixation en X)	Tornillos #8 x 1/4" (Para sujetador en X)	4	
3	Retraction pin	Cheville d'ancrage	Pasador de retracción	4	
4	#8 x 3/8" Screw (for retraction pin)	Vis #8 x 3/8" (pour cheville d'ancrage)	Tornillos #8 x 3/8" (para pasador de retracción)	4	

PARTS INCLUDED IN SHELF PACK | PIÈCES COMPRISSES DANS LA BOÎTE DE LA TABLETTE
| PIEZAS INCLUIDAS EN LA CAJA DE LA REPISA

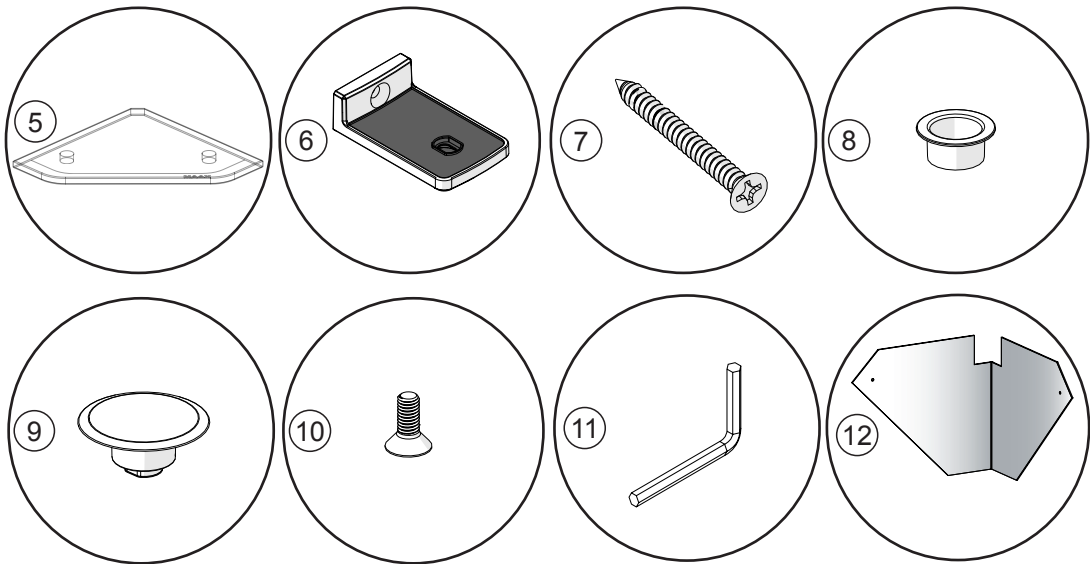

#	Part	Nom de la pièce	Pieza	Qty/Qté	Code
5	Glass shelf	Tablette en verre	Repisa	1	10060011
6	Bracket	Support	Soporte de repisa	2	
7	#10 x 2" screws	Vis #10 x 2"	Tornillos #10 x 1 1/2" (repisa)	2	
8	Plastic washer	Rondelle en plastique	Arandela en plástico para repisa	2	
9	Support cap	Capuchon	Tapa de la fijación de repisa	2	
10	#10 x 1/2" screws	Vis #10 x 1/2"	Tornillos #10 x 1/2" (para repisa)	2	
11	Allen key	Clé Allen	Llave allen	1	
12	Template	Gabarit	Plantilla de perforación	1	

COMPONENTS | COMPOSANTES | COMPONENTES

#	Part	Nom de la pièce	Pieza	Qty/Qté
13	Bathtub	Baignoire	Base	1
14	Back wall	Mur arrière	Muro posterior	1
15	Side Wall	Mur de côté	Muro lateral	2

OVERVIEW | VUE D'ENSEMBLE | VISTA GENERAL

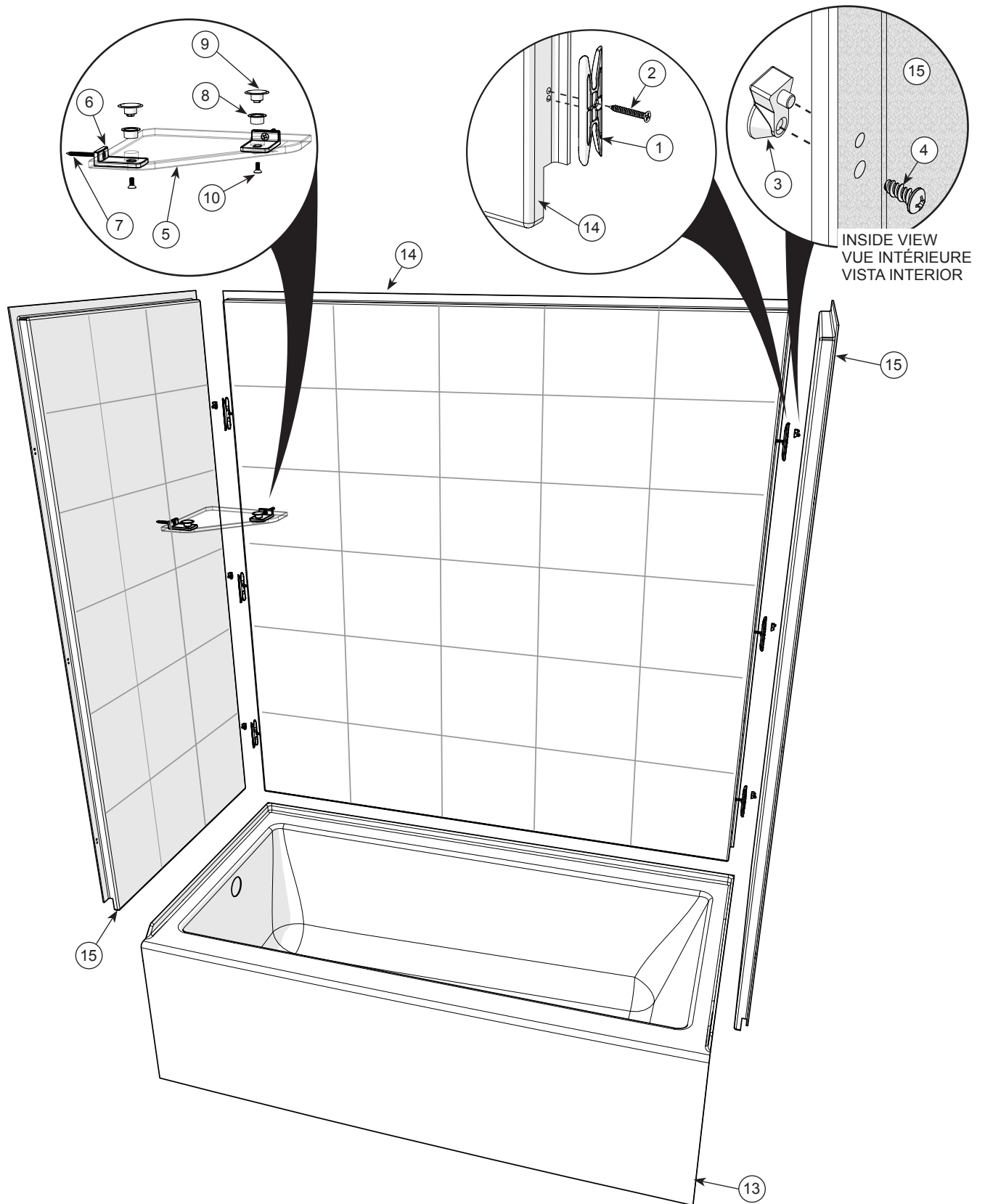

For a worry free installation follow all instructions and check them off as you go.



FINAL VISUAL INSPECTION
 Note: Not doing so could void your warranty

After removing the protective film and prior to completing the installation, perform a visual inspection. If defects are visible, **INTERRUPT THE INSTALLATION** and communicate with our customer service: 1-877-438-6229

STEP 1 Building the structure

Before starting make sure to have all parts and components refer to page 4.

Build a structure based on the dimensions in the chart below.

IF STRUCTURE IS ALREADY BUILT CHECK THAT IT RESPECTS THE DIMENSIONS BELOW

COMPATIBLE BATHTUBS	No	A	B	C	D	E
AVENUE 6030	102576 105927	59 7/8"	31" min.	13 5/8"	8 3/8"	20 1/4"
BOSCA 6030	106394	59 3/4"	30" min.	14"	8 1/2"	18 3/8"
BOSCA 6030 AFR	106395	59 3/4"	30" min.	14"	8 1/2"	20 3/8"
COCOON 6030 IFS	105822	Between 60" - 60 1/4"	31 1/2" min.	14 1/8"	9 3/8"	19 5/8"
BROME	105821	Between 60" - 60 1/4"	31 1/2" min.	14 1/8"	9 3/8"	19 5/8"
EXHIBIT 6030 (IFS)	105519	59 3/4"	30" min.	14"	10"	17 3/8"
EXHIBIT 6030 (IFS) AFR	105511	59 3/4"	30" min.	14"	10"	19 3/8"
NEW TOWN 6030 IFS	105454	59 3/4"	30" min.	14"	10"	19 3/8"
NOMAD 6030 AFR	106662	60"	31" min.	14"	8 1/2"	20"
NOMAD 6030	106663	60"	31" min.	14"	8 1/2"	18"
RUBIX 6030	105815	59 3/4"	30" min.	14"	8 1/2"	18 3/8"
RUBIX 6030 AFR	105816	59 3/4"	30" min.	14"	8 1/2"	20 3/8"
RUBIX ACCESS 6030 IFS	106348	59 7/8"	30" min.	14 1/4"	8 1/2"	18 3/8"
RUBIX ACCESS 6030 IFS AFR	106349	59 7/8"	30" min.	14 1/4"	8 1/2"	20 3/8"

COMPATIBLE BATHTUBS	No	A	B	C	D	E
EXHIBIT 6032 (IF)	105514 105550	59 3/4"	32" min.	16"	10"	20"
EXHIBIT 6032 (IFS) AFR	105512 105548	59 3/4"	32" min.	15"	10"	19 3/8"
EXHIBIT 6032 IFS	105520 105549	59 3/4"	32" min.	15"	10"	17 5/8"
JAXI 6032	106883	60"	33" min.	16"	8 1/2"	17 3/4"
MACKENZIE 6032 AFR	106668	60"	33" min.	15"	8 1/2"	20"
MACKENZIE 6032	106669	60"	33" min.	15"	8 1/2"	18"
NEW TOWN 6032 IF	105467	59 3/4"	32" min.	16"	10"	20"
NEW TOWN 6032 IFS	105456	59 3/4"	32" min.	15"	10"	19 3/8"
NOMAD 6032 AFR	106666	60"	33" min.	15"	8 1/2"	20"
NOMAD 6032	106667	60"	33" min.	15"	8 1/2"	18"
RUBIX 6032	105705	59 3/4"	32" min.	15"	8 1/2"	18 3/8"
RUBIX 6032 AFR	105704	59 3/4"	32" min.	15"	8 1/2"	20 3/8"

If installing a door, double the studs (2x4) where the wall jambs will be installed.

Verify the wall studs are square, plumb and the flooring is perfectly level.

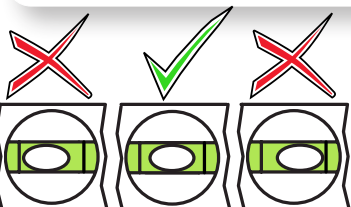

Leveling the floor is critical for a properly aligned installation. Auto leveling cement can be used to level floor. Be careful not to block the drain hole position.

1.1 Check me!



Top view of structure

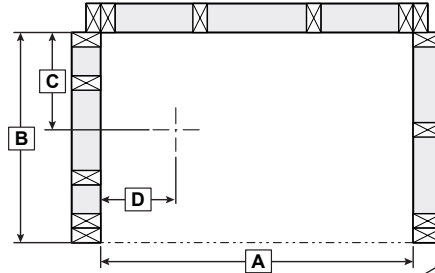

Install a standard 1" x 3" piece of wood (3/4" x 2 1/2") (20 mm x 63 mm) all around the alcove, at E height minus 1/8". The 1" x 3" must be cut down to 1/4" inside dimension B.

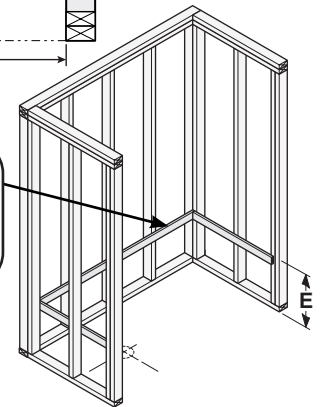

Respect front and inside corner studs position, others may vary.

1.2 Check me!



1.3 Check me!

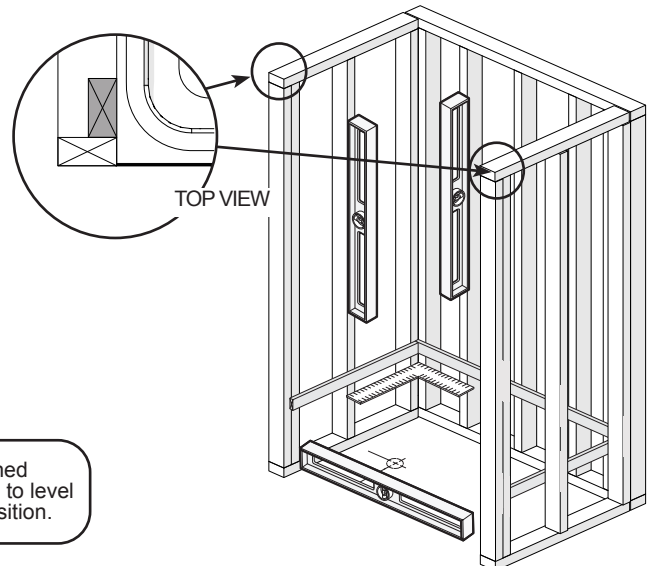

Cut out an approximate 6" x 6" opening around the drain center outlined by measurements C and D. See image to the right and the chart above. We recommend that a plumber completes the drain pipe connection.

1.3
Check me!

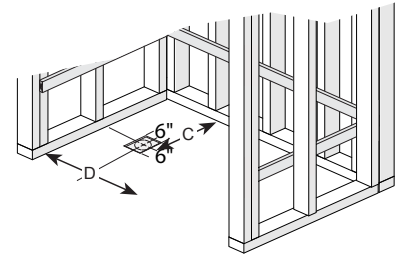

STEP 2 Installing the bathtub



Remove clear plastic film on the bathtub. Use cardboard on the bathtub floor as protection until the installation is complete.

Install the bathtub (13) pushing it completely against the back studs. Center the bathtub left to right inside the alcove leaving equal spacing on both sides.



Centering the bathtub left to right is critical for side wall installation.

2.1
Check me!

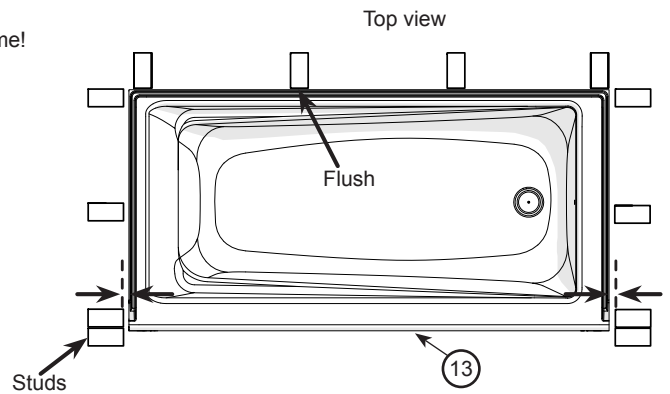

Connect plumbing (drain, overflow, faucets, etc.) according to local standards and to general rules in the bathtub installation guide. Make sure that all joints are waterproof.

2.2
Check me!



Verify that the bathtub is completely level on all sides. Confirm that the drain pipe is centered.

We recommend that a plumber completes the drain pipe connection.

2.3
Check me!

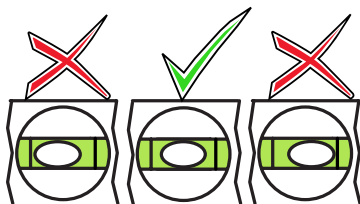
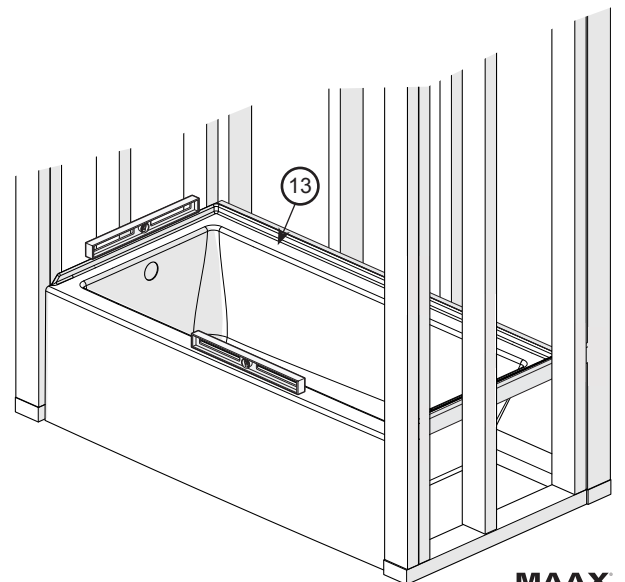

Leveling the bathtub is critical for wall alignment

STEP 2

Installing the bathtub (cont'd)

If needed use wood shims between the studs and the fastening flange to maintain centered position of bathtub.

**DO NOT USE SHIMS UNDER THE BATHTUB TO LEVEL!
DOING SO WILL VOID THE MAAX WARRANTY!**

2.4
Check me!

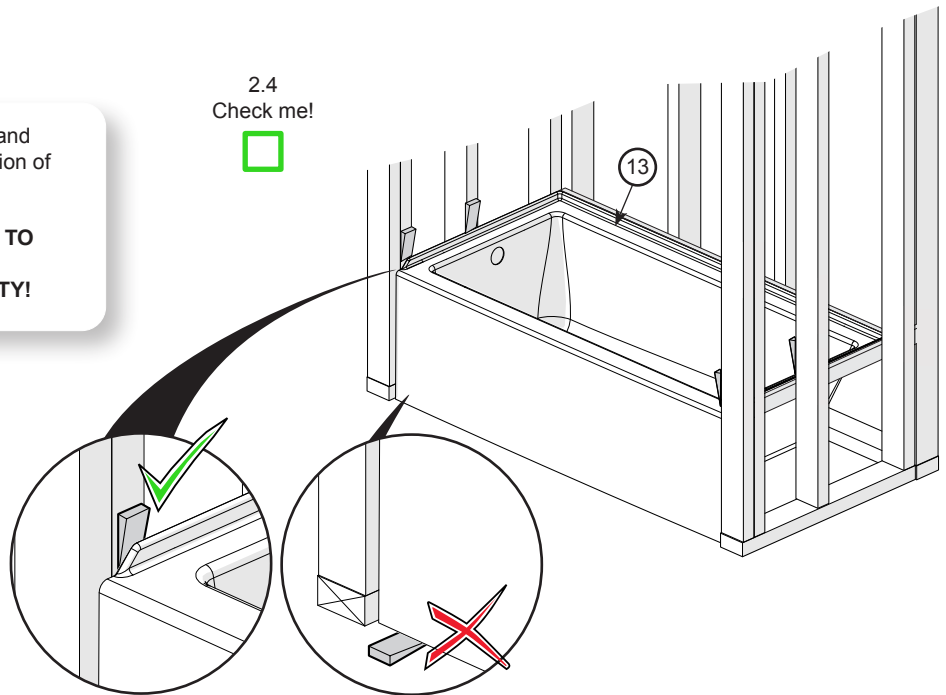

With a 1/8" bit, drill holes in the bathtub fastening flange then secure the bathtub to all the wall studs with #8 x 1 3/4" screws (not included). **Only pre-drill the flange not the studs.**

HOLES MUST BE FILLED WITH SILICONE BEFORE SCREWING

HAND TIGHTEN ONLY !

CUT THE EXCESS PART OF SHIMS

2.5
Check me!

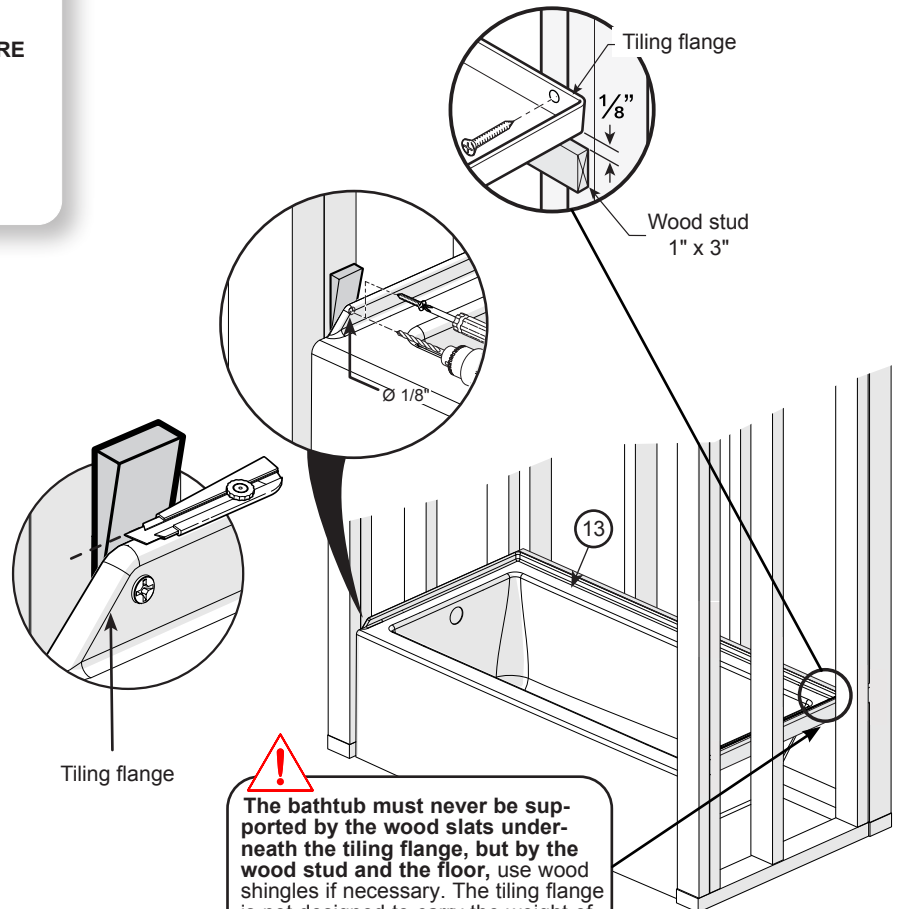

The bathtub must never be supported by the wood slats underneath the tiling flange, but by the wood stud and the floor, use wood shingles if necessary. The tiling flange is not designed to carry the weight of the bathtub.

STEP 3 Installing Ulok system on the walls

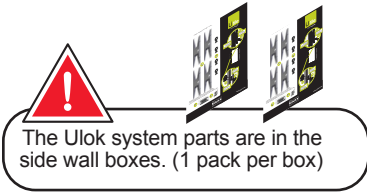

Install three X fasteners (1) on each side of the back wall (14) in the pre drilled holes using the screws provided (2).

Quick tip There is a positioning pin on X fastener so they can only be installed one way.

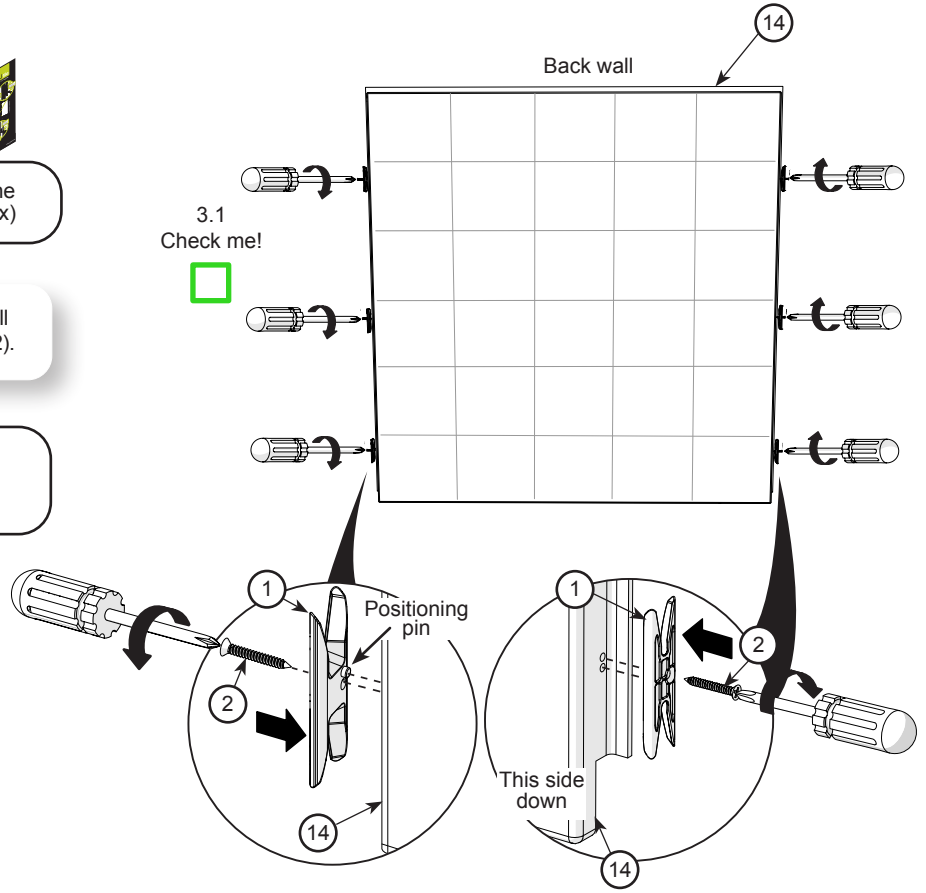

Fasten 3 retraction pins per side wall in the pre drilled holes with the screws provided (4) to the left-hand or right-hand fastening flange of the side walls (15) depending on which side the wall will be installed on.

Quick tip The side walls are interchangeable. For left wall install the pins on the right side, for the right wall install the pins on the left side.

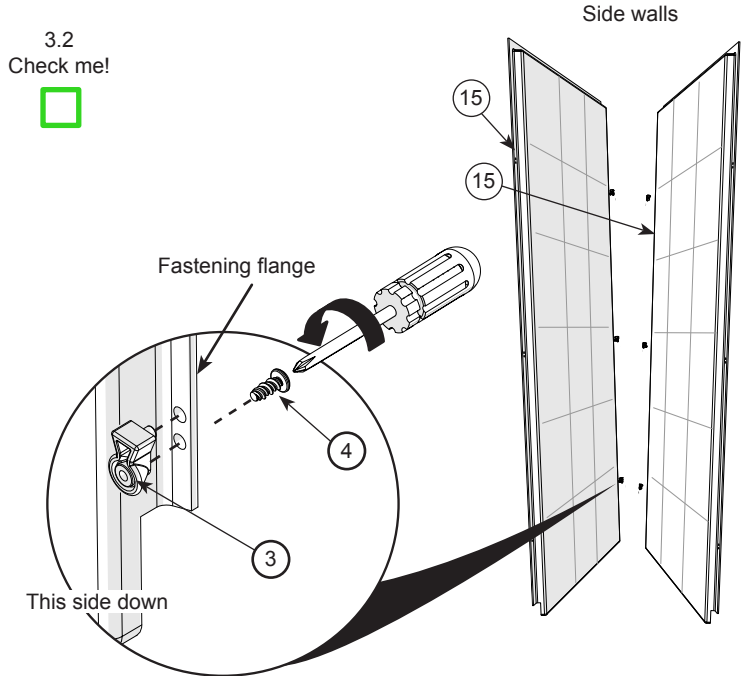

STEP 4 Temporary installation of the back wall

Pull back the protective film on the walls (14-15) at least 3" away from **all edges**. Keep the remaining protective film on the walls and base.

Position and level the back wall (14) by sitting it on the deck at the back of the bathtub.

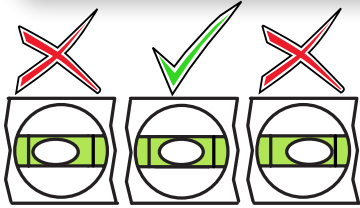

Plumbing the back wall is critical for alignment of the side walls

Quick tip 

Installing the walls temporarily will ensure proper wall alignment before permanent installation. Make sure the wall is plumb and centered on the bathtub.

4.1
Check me!



4.2
Check me!

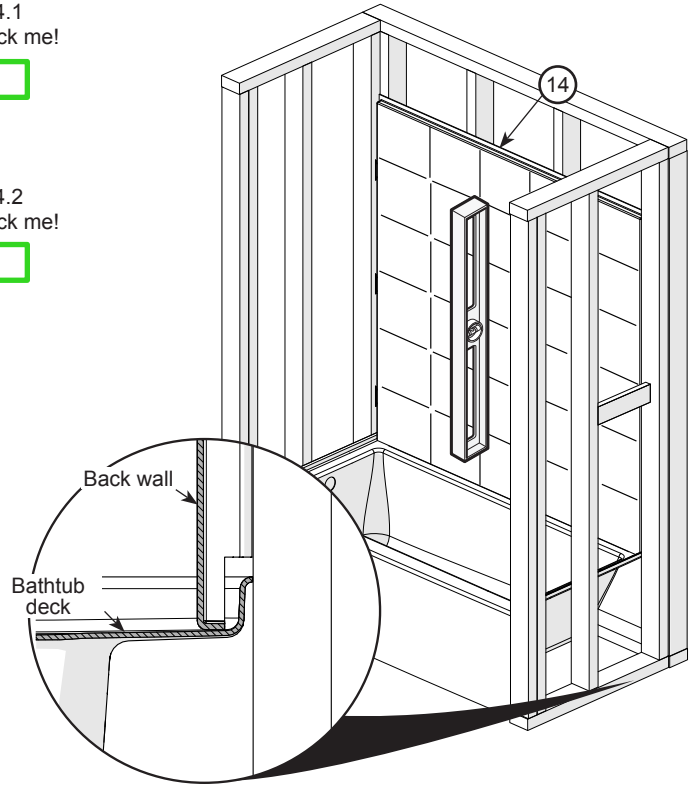

With a 1/8" bit, drill holes in the back wall fastening flange (14) at the top aligned with each stud. **Only pre-drill the flange not the studs.** Then, secure the back wall (14) with **one #8 x 1 3/4"** screw (not included) in one of the pre-drilled holes.

IMPORTANT: HAND TIGHTEN ONLY. TEMPORARY INSTALLATION.

Quick tip 

Push the bottom of the back wall with your foot when fastening in place.

4.3
Check me!



min. 3/16"
max. 3/8"

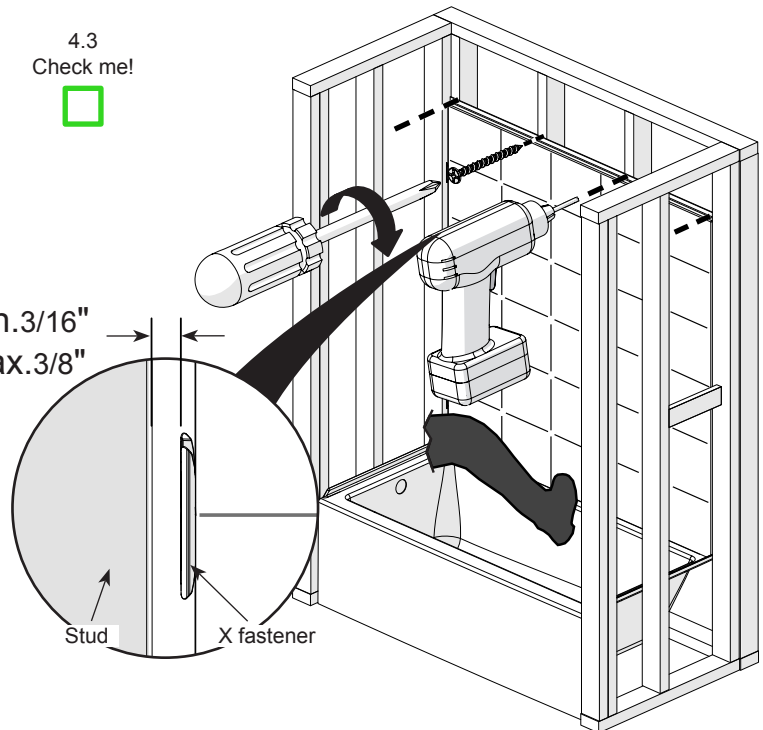

STEP 5 Temporary installation of the side walls

Install the side wall (15) on the opposite side of the faucet installation. Lift the wall approximately 3" above the deck of the bathtub, push it completely against the back wall then lower the side wall into position.

!
It is critical that all 3 retraction pins engage with the X fasteners. There should be no gap between the walls.

Quick tip The side wall should now line up with the front of the bathtub.

Quick tip Place a level vertically on the side wall. If the wall is not straight, make sure that the retraction pins are properly inserted in the X fasteners.

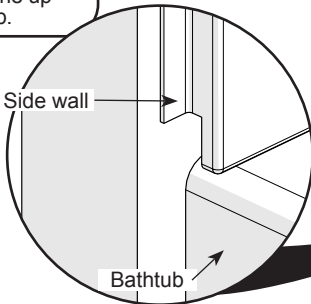

5.1
Check me!

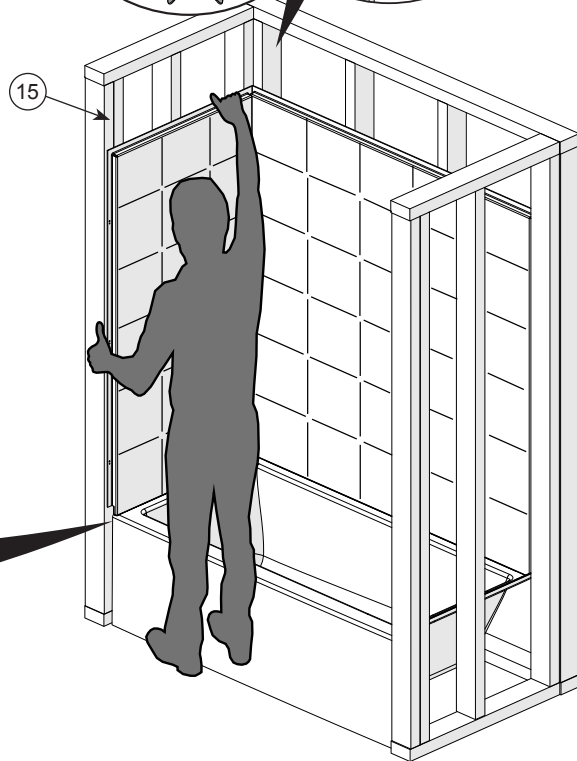
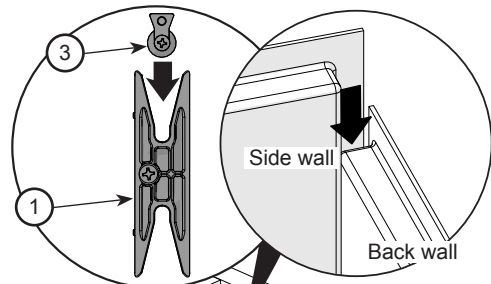

5.2
Check me!



With a 1/8" bit, drill holes in the side wall fastening flange (15) at the top aligned with each stud. **Only pre-drill the flange not the studs.** Then, secure the side wall (15) with **one #8 x 1 3/4"** screw (not included) in one of the pre-drilled holes.

IMPORTANT: HAND TIGHTEN ONLY. TEMPORARY INSTALLATION.

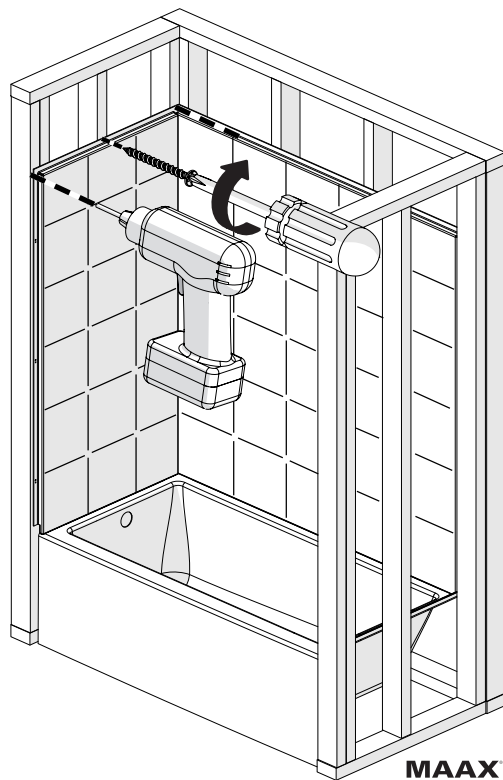

STEP 5 Temporary installation of the side walls (Cont'd)

Measure the distance between the front face of the back wall (14) and the center of the faucet. Then measure the distance from the top of the bathtub deck to the center of the faucet.

Using those two measurements mark the position of the faucet hole on the remaining side wall. Measure from the side and bottom of the side wall where the retraction pins are installed. Repeat this process for all required faucet holes.

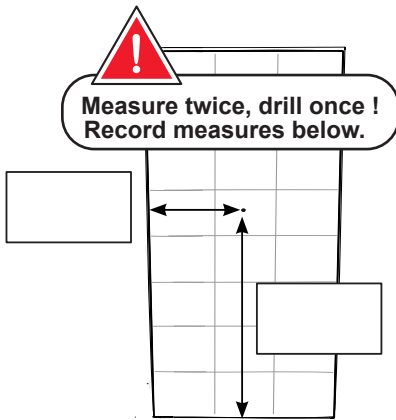

5.3
Check me!

5.4
Check me!

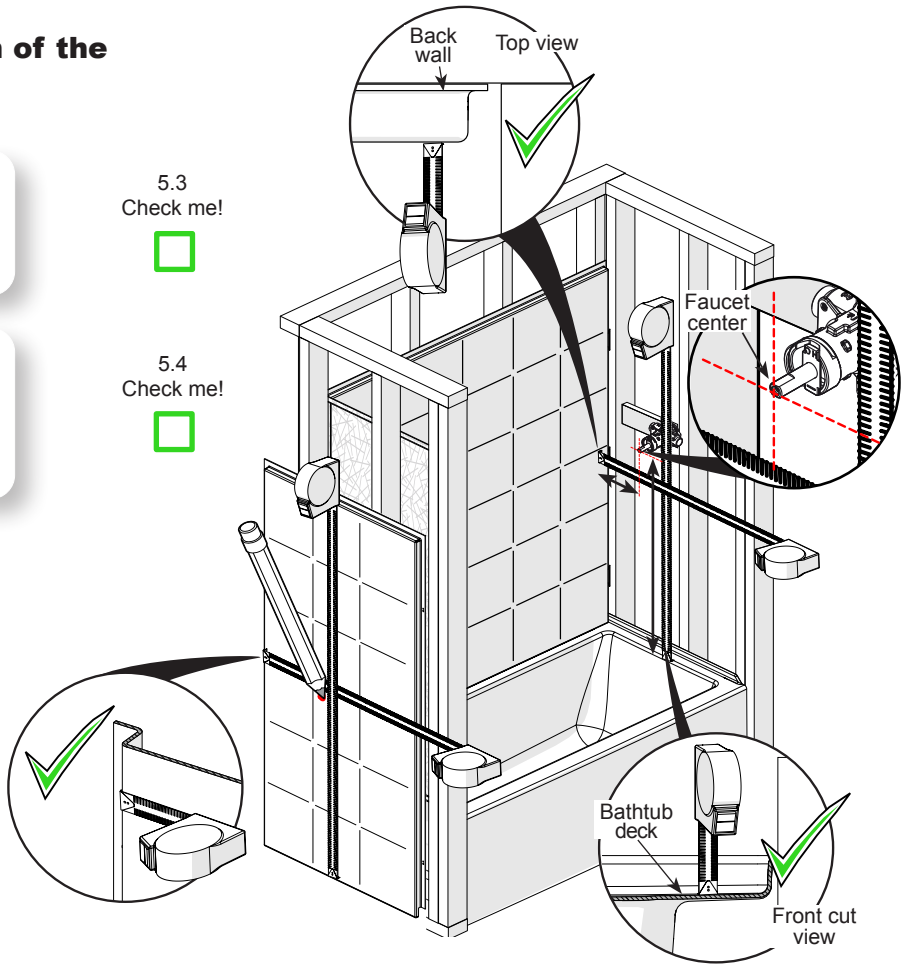

Drill a hole from front for the faucets at the previously marked positions. Pre-drill the hole with the 1/8" drill bit. The hole saw size is determined by the faucet type; refer to the faucet installation manual for hole saw size.

5.5
Check me!

Quick tip

Hole saws can be rented at your local hardware store or any tool rental location.

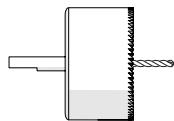

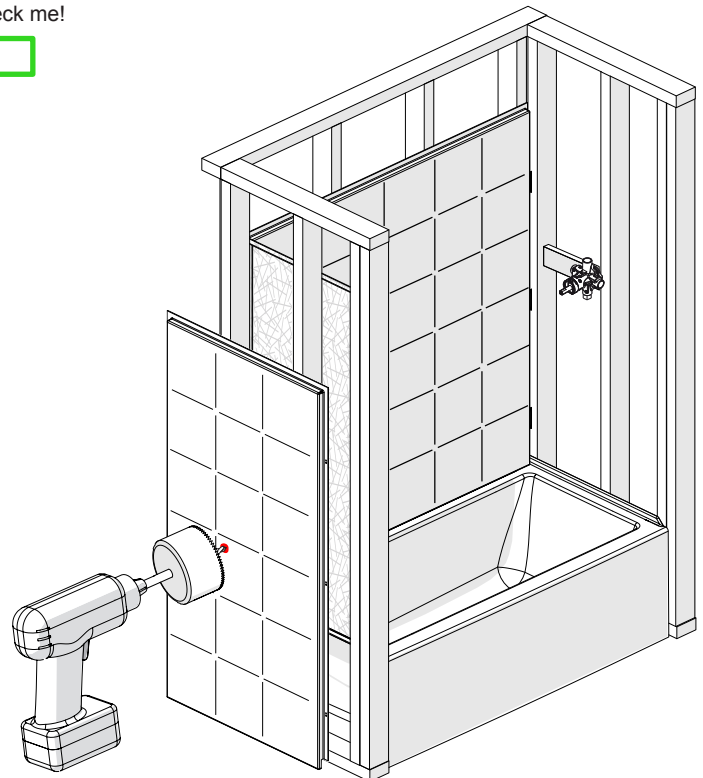

For safe hole saw usage always pre-drill a hole and wear safety glasses when drilling.



STEP 5 Temporary installation of the side walls (Cont'd)

Install the side wall (15) with the drilled faucet hole(s). Lift the wall approximately 3" above the deck of the bathtub, push it completely against the back wall then lower the side wall into position.

 It is critical that all 3 retraction pins engage with the X fasteners. There should be no gap between the walls.

Quick tip  The side wall should now line up with the front of the bathtub.

Quick tip  Place a level vertically on the side wall. If the wall is not straight, make sure that the x-fasteners are properly inserted

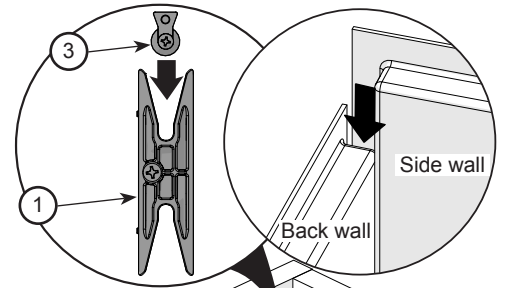
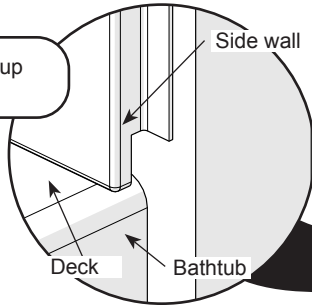

5.6
Check me!

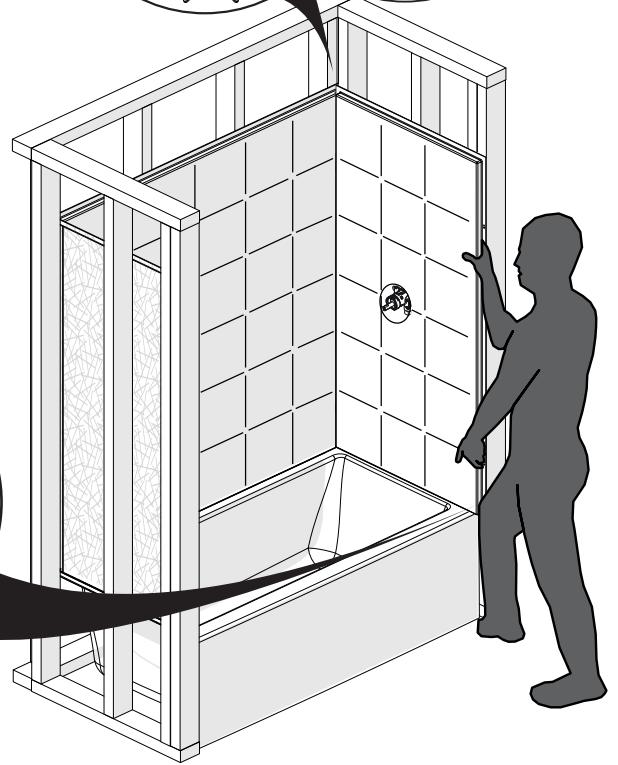

With a 1/8" bit, drill holes in the side wall fastening flange (15) at the top aligned with each stud. Only pre-drill the flange not the studs. Then, secure the side wall (15) with one #8 x 1/4" screw (not included) in one of the pre-drilled holes.

IMPORTANT: HAND TIGHTEN ONLY. DO NOT OVER-TIGHTEN THE SCREW.

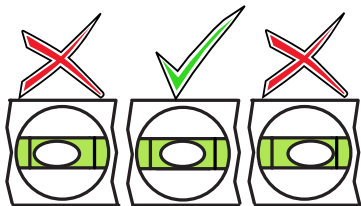

 **BEFORE CONTINUING, VALIDATE THAT ALL THE WALLS ARE LEVEL, PLUMB AND SQUARE**

5.7
Check me!

5.8
Check me!

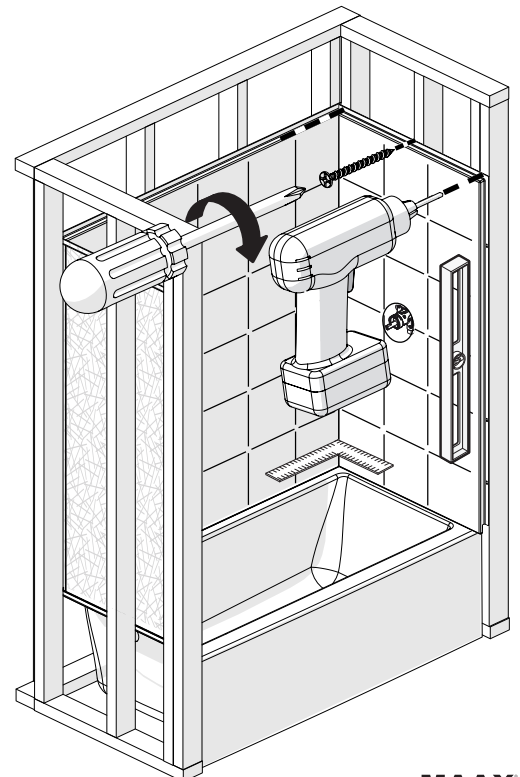

STEP 6 Final installation of back wall

Remove all walls from the structure.

Clean the bathtub and apply a bead of silicone on the deck at 3/8" from the back fastening flange. Run the bead of silicone the entire length of the bathtub and 1" on each side as well.

Secure the wall to the wall studs with #8 x 1 1/4" screws (not included) in the previously drilled holes. Also, secure the wall by the fastening flanges on the side of the wall. Use the pre-dilled holes. **If needed, use shims to keep wall plumb, square and leveled. (Cut shim excess)**

IMPORTANT: HAND TIGHTEN ONLY. DO NOT OVER-TIGHTEN THE SCREWS.



It is critical for the side wall installation for there to be at least 1/8" and no more than 3/8" between the stud and the X fastener.

Quick tip

Hold the bottom of the back wall with your foot when fastening in place.

6.1
Check me!



6.2
Check me!

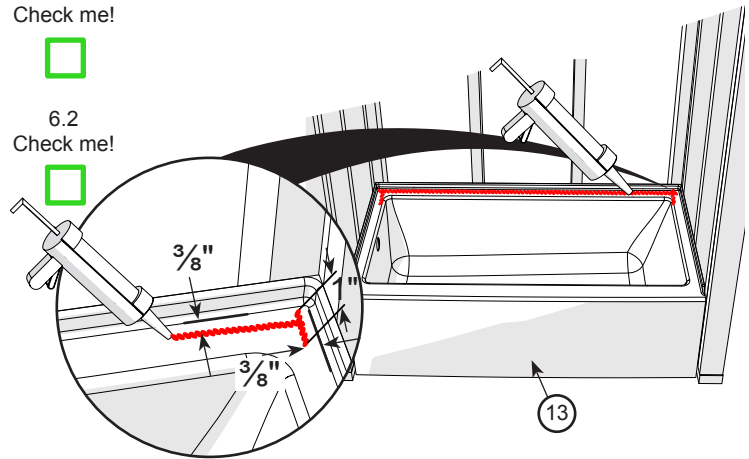

6.3
Check me!



min. 3/16"
max. 3/8"

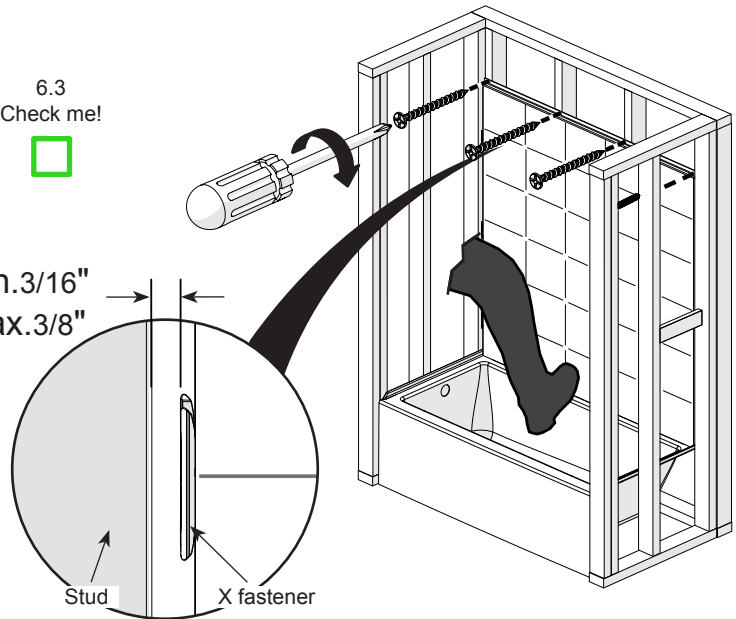

6.4
Check me!



Apply a bead of silicone on both sides of base (13) threshold at 3/8" from the base side fastening flanges. Apply silicone on both side of the back wall (14) just before the wall side radius. **The silicone applied on the base and vertically on the back wall must overlap.**

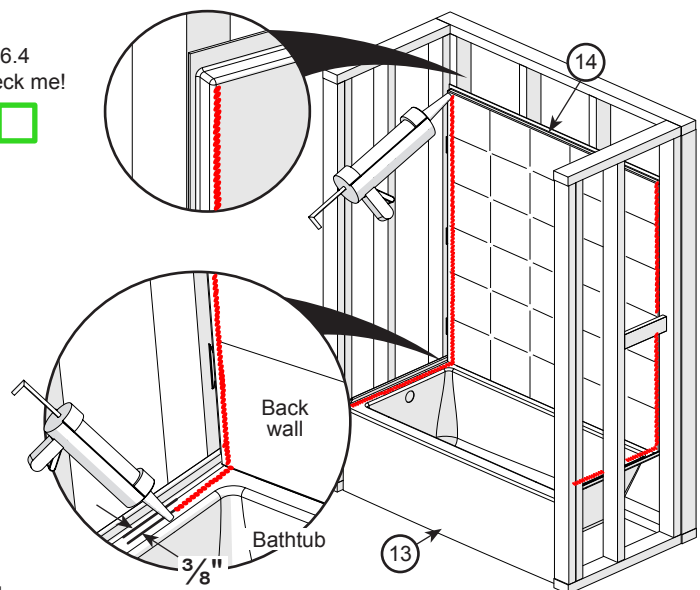

STEP 7 Final installation of side walls

Install the side wall (15) opposite the faucet. Lift the wall approximately 3 inches above the deck of the bathtub, push it completely against the back wall then slide the side wall into position.

WIPE OFF EXCESS SILICONE

7.1
Check me!

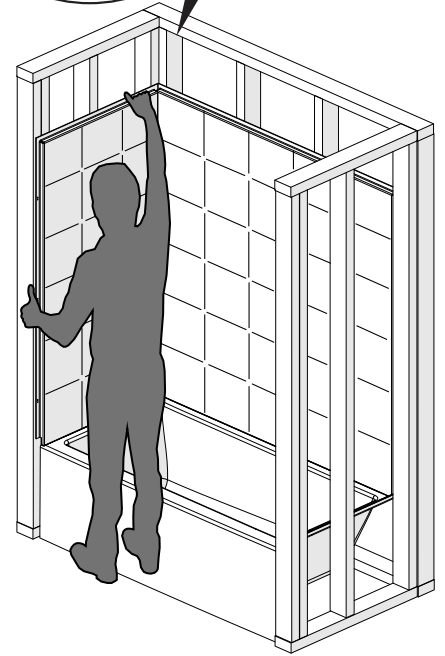
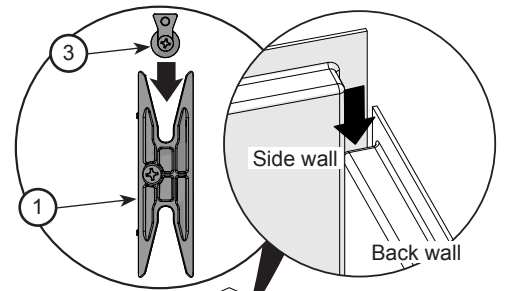

Install the side wall (15) with the faucet hole. Lift the wall approximately 3 inches above the deck of the bathtub, push it completely against the back wall then slide the side wall into position.

WIPE OFF EXCESS SILICONE

7.2
Check me!

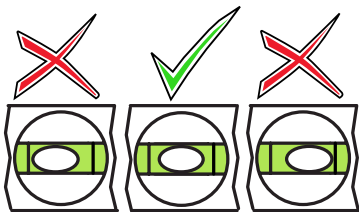
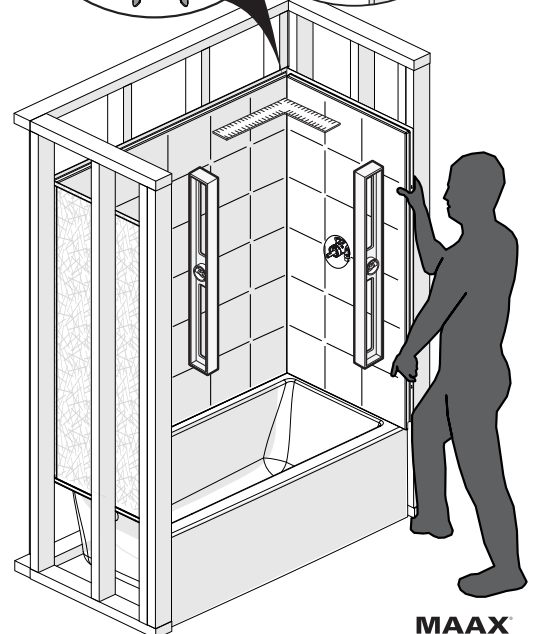
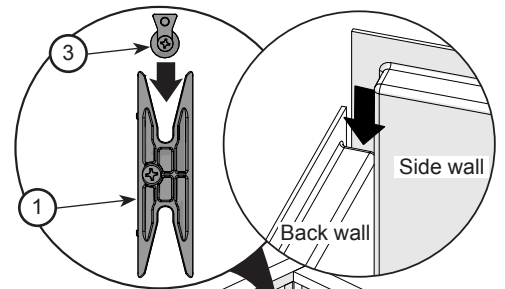

BEFORE CONTINUING, VALIDATE THAT ALL THE WALLS ARE LEVEL, PLUMB AND SQUARE

7.3
Check me!



STEP 7 Final installation of side walls (cont'd)

Secure the walls to the wall studs with #8 x 1 1/4" screws (not included) in the previously drilled holes. Also, secure the walls by the flanges on the sides of the walls. Use the pre-dilled holes. **If needed, use shims to keep walls plumb, square and leveled. (Cut shim excess)**

IMPORTANT: HAND TIGHTEN ONLY. DO NOT OVER-TIGHTEN THE SCREWS.

7.4
Check me!

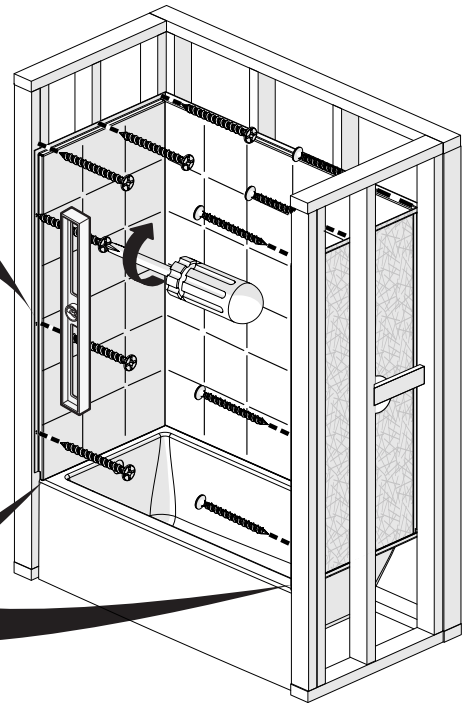
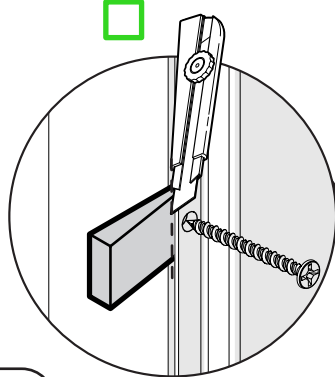

Quick tip

THE SIDE WALLS SHOULD LINE UP WITH THE BATHTUB

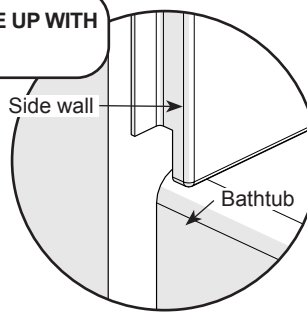

STEP 8 Marking and drilling the glass shelf holes

Place the template in the corner of the shower where you want to install your shelf. Slide the template up until the points on the left and right-hand side of the template are at the height you want your shelf. Use a pencil, marker or wax pencil to mark the spots where the holes for the shelf will be drilled. Drill the holes using a 9/64" drill bit.

Check me!

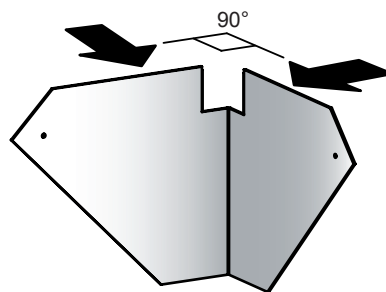
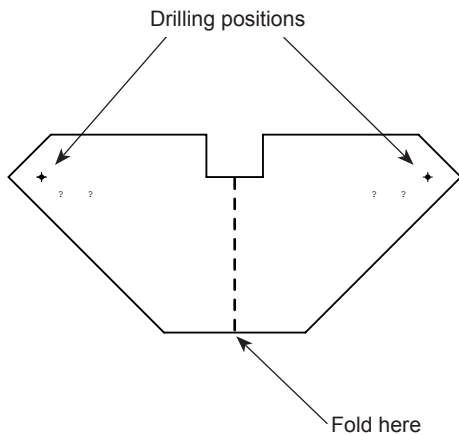
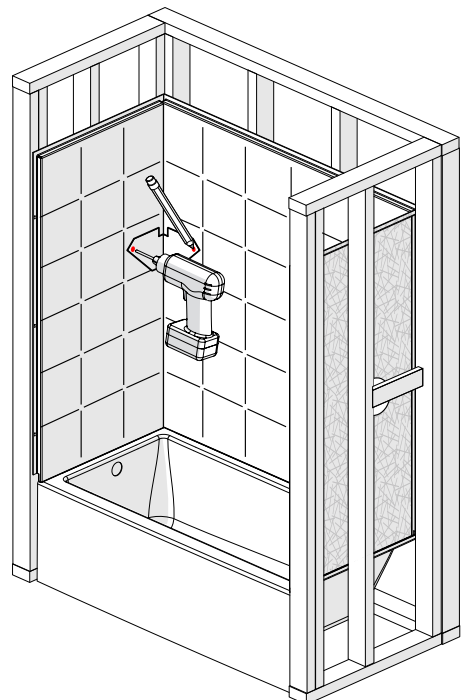

STEP 9 Silicone

Apply a bead of silicone all along the wall to wall and wall to base joints. For a smooth finish you can remove the silicone excess with a damp rag or wet finger.

Quick tip  Apply masking tape on both sides of the joint where you will run a bead of silicone. Apply the silicone, smooth with a wet finger then remove the masking tape.

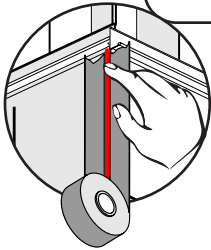

 All faucets installed on the walls must be sealed with silicone.

Check me!



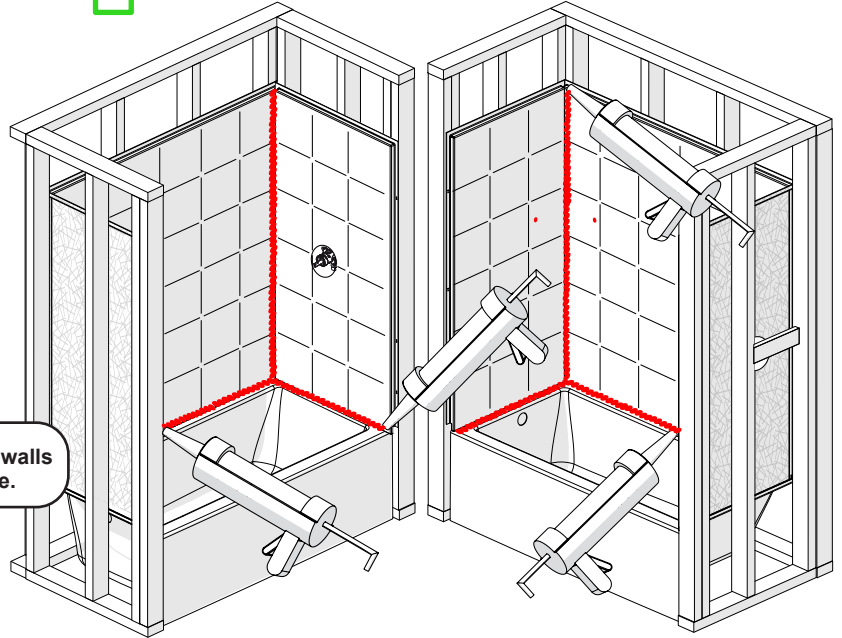

 Remove protective film from walls

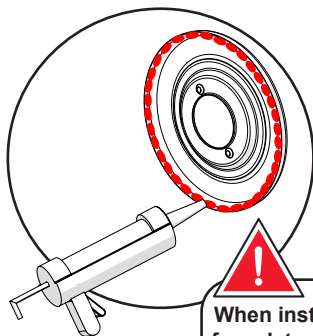

STEP 10 Glass shelf installation

Apply silicone in the previously drilled holes on the side and back walls. Apply silicone to the rear of the shelf brackets (6). Fasten the brackets in place using the screws (7).



 When installing the faucet faceplate or any other component, be sure to silicone the outer edge.

10.1
Check me!

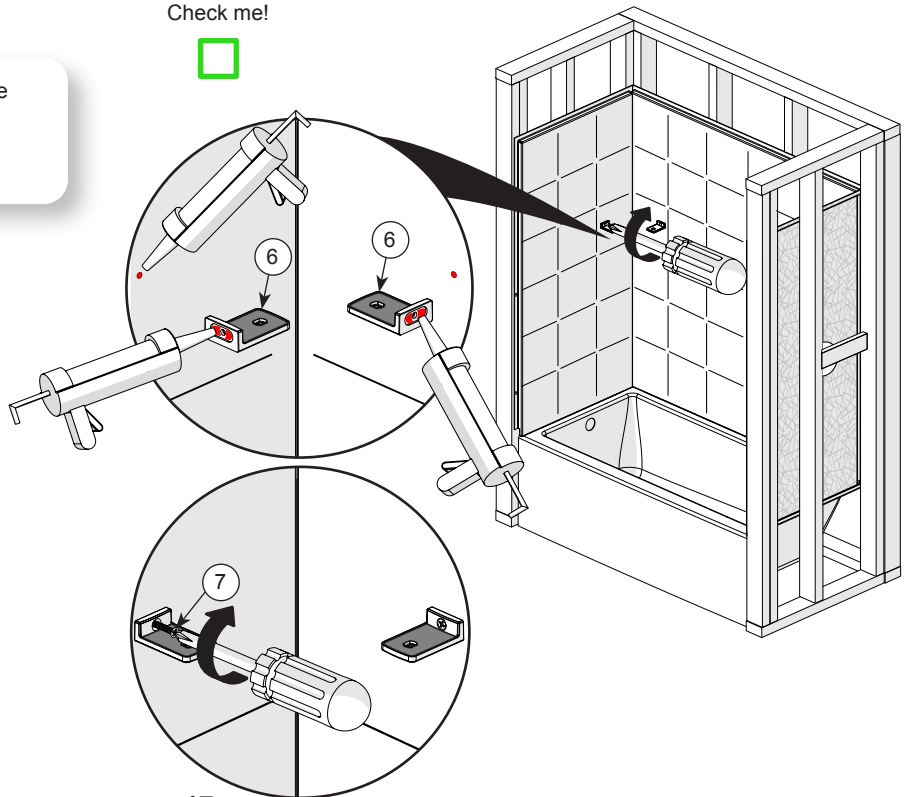

STEP 10 Glass shelf installation (cont'd)

Clean the top rubber part of the brackets with a damp cloth, then place the glass shelf (5) over the brackets (6).

10.2
Check me!



Quick tip



If you can read the MAAX logo, the shelf is installed on the right side.

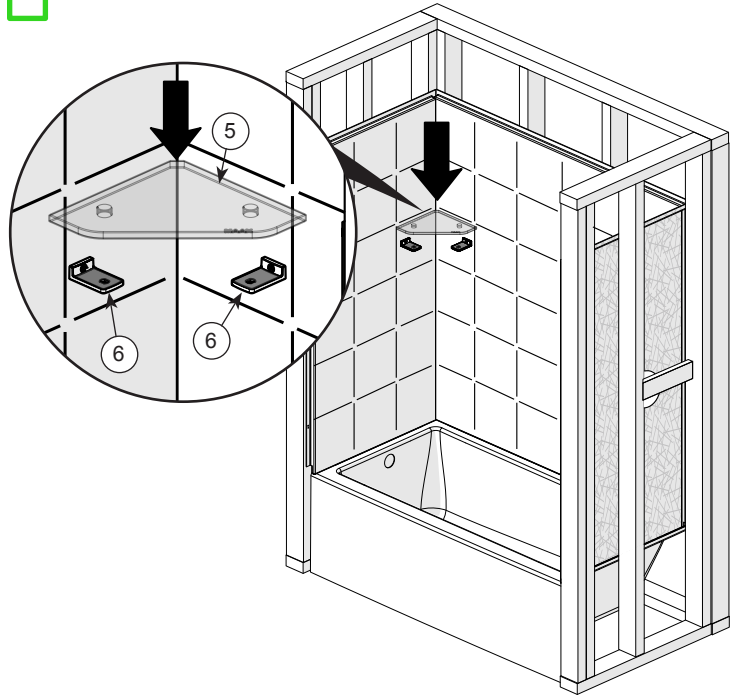

Insert the washers (8) in the shelf support cap (9). Align and insert the shelf support caps (9) with the holes of the glass and the holes of the shelf brackets (6). Screw from the bottom of the shelf with the # 10 x 1/2" screws (10) and tighten by hand with the Allen key (11).

10.3
Check me!

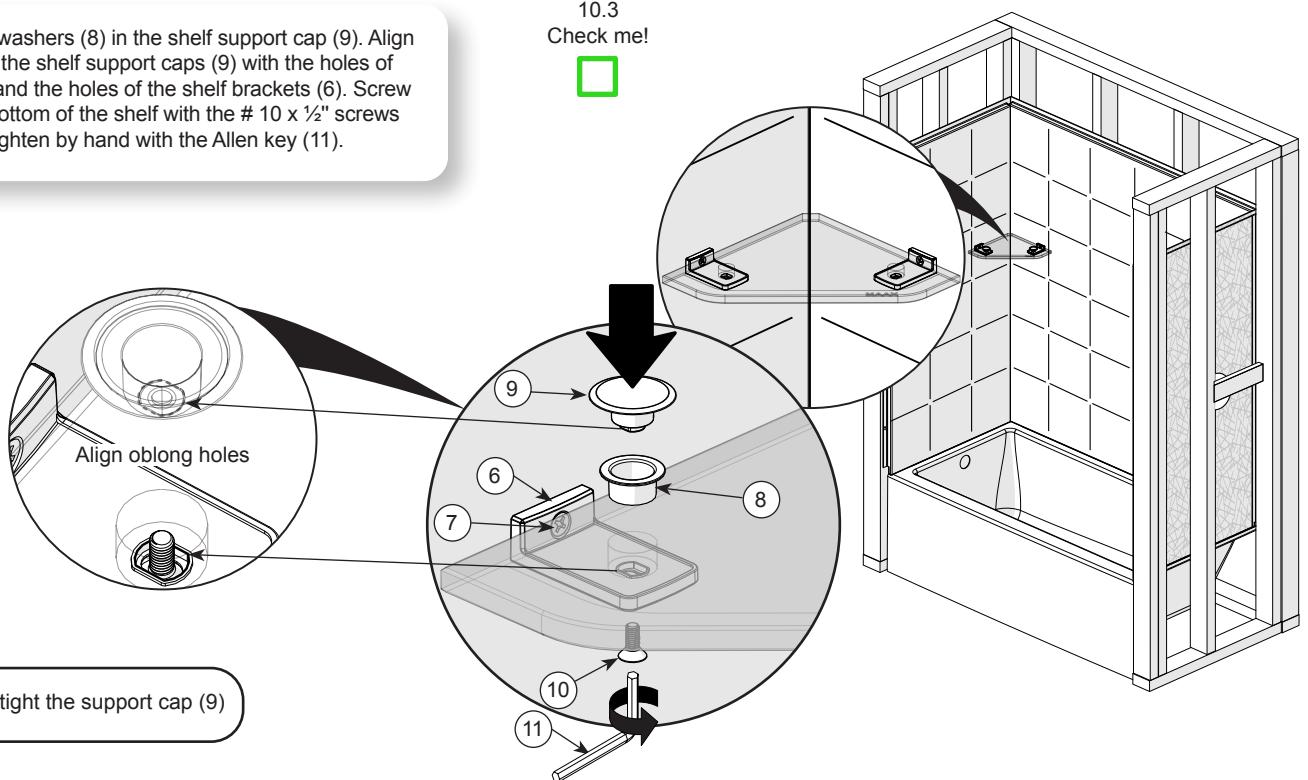

Align oblong holes

Do not overtight the support cap (9)

STEP 11 Wall finish

For the wall finish you can install your finishing material on top of the flange or on the wall edge as shown.

Check me!

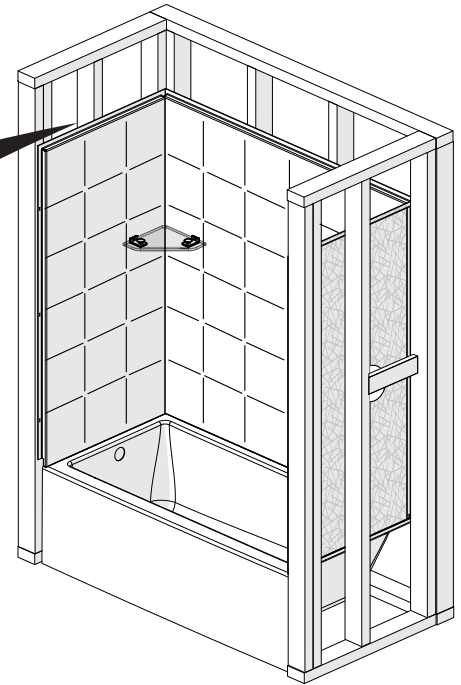
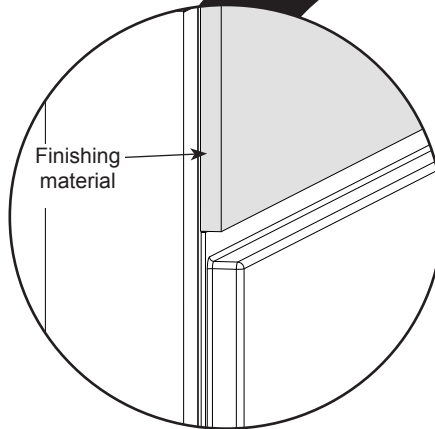
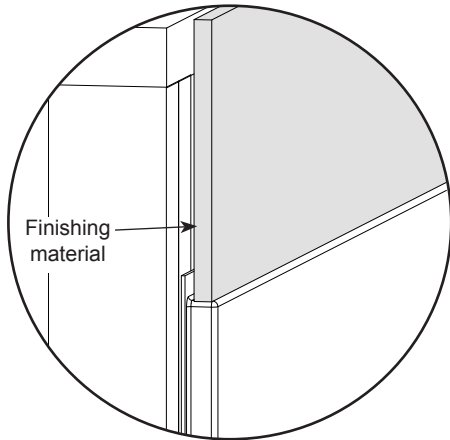

Maintenance tips

MAAX uses durable, **high quality materials and innovative technology** in manufacturing and design of its products to reduce the time needed to spend cleaning and caring for them. However, proper and regular maintenance is still vital.

Follow these general use and maintenance tips, as well as any that come with the MAAX products and you will be rewarded with years of great service.

U tile shower walls / bathtubs / shower bases / shower doors maintenance

- ☒ **Clean regularly** with a non-abrasive cleaning spray or cream based cleansing agent.
- ☒ **Never use tile or grout cleaner** as they are not adequate for U tile products and could damage the unit.
- ☒ **Never use abrasive cleansers, scrapers, metal brushes** or anything that could scratch or dull the surface of your MAAX unit.
- ☒ In order to avoid damaging the finish of the unit when renovating, **remove plaster residues** from surfaces with a plastic or wooden spatula wrapped in a moist cloth.
- ☒ **Wipe down your shower door after every use** with a squeegee or soft cloth. This reduces the buildup from soap, bath additives, natural body oils and mineral deposits in water, making cleaning easy and helping to maintain the unit's natural luster.
- ☒ **Repair nicked or damaged surfaces** immediately using MAAX repair kits for U tile products. For more information call customer services at **1-877GET-MAAX (1-877-438-6229)**.



Pour une installation sans tracas suivre les étapes une à une et les cocher lorsqu'elles sont terminées.



INSPECTION VISUELLE FINALE

Note: Ne pas le faire pourrait annuler votre garantie. Après avoir enlevé le film protecteur et avant de terminer l'installation, effectuez une inspection visuelle. Si les défauts sont visibles, **INTERROMPRE L'INSTALLATION** et communiquer avec notre service à la clientèle: 1-877-438-6229

ÉTAPE 1 Construction de la structure

Avant de commencer assurez-vous d'avoir tout les pièces et composants se référer à la page 4.

Construire une structure qui respecte les dimensions mentionnées dans le tableau.

SI LA STRUCTURE EST EXISTANTE, S'ASSURER QUE SES DIMENSIONS CORRESPONDENT À CELLES DU TABLEAU.

BAIGNOIRES COMPATIBLES	No	A	B	C	D	E
AVENUE 6030	102576 105927	59 7/8"	31" min.	13 5/8"	8 3/8"	20 1/4"
BOSCA 6030	106394	59 3/4"	30" min.	14"	8 1/2"	18 3/8"
BOSCA 6030 AFR	106395	59 3/4"	30" min.	14"	8 1/2"	20 3/8"
COCOON 6030 IFS	105822	Between 60" - 60 1/4"	31 1/2" min.	14 1/8"	9 3/8"	19 5/8"
BROME	105821	Between 60" - 60 1/4"	31 1/2" min.	14 1/8"	9 3/8"	19 5/8"
EXHIBIT 6030 (IFS)	105519	59 3/4"	30" min.	14"	10"	17 3/8"
EXHIBIT 6030 (IFS) AFR	105511	59 3/4"	30" min.	14"	10"	19 3/8"
NEW TOWN 6030 IFS	105454	59 3/4"	30" min.	14"	10"	19 3/8"
NOMAD 6030 AFR	106662	60"	31" min.	14"	8 1/2"	20"
NOMAD 6030	106663	60"	31" min.	14"	8 1/2"	18"
RUBIX 6030	105815	59 3/4"	30" min.	14"	8 1/2"	18 3/8"
RUBIX 6030 AFR	105816	59 3/4"	30" min.	14"	8 1/2"	20 3/8"
RUBIX ACCESS 6030 IFS	106348	59 7/8"	30" min.	14 1/4"	8 1/2"	18 3/8"
RUBIX ACCESS 6030 IFS AFR	106349	59 7/8"	30" min.	14 1/4"	8 1/2"	20 3/8"

BAIGNOIRES COMPATIBLES	No	A	B	C	D	E
EXHIBIT 6032 (IF)	105514 105550	59 3/4"	32" min.	16"	10"	20"
EXHIBIT 6032 (IFS) AFR	105512 105548	59 3/4"	32" min.	15"	10"	19 3/8"
EXHIBIT 6032 IFS	105520 105549	59 3/4"	32" min.	15"	10"	17 5/8"
JAXI 6032	106883	60"	33" min.	16"	8 1/2"	17 3/4"
MACKENZIE 6032 AFR	106668	60"	33" min.	15"	8 1/2"	20"
MACKENZIE 6032	106669	60"	33" min.	15"	8 1/2"	18"
NEW TOWN 6032 IF	105467	59 3/4"	32" min.	16"	10"	20"
NEW TOWN 6032 IFS	105456	59 3/4"	32" min.	15"	10"	19 3/8"
NOMAD 6032 AFR	106666	60"	33" min.	15"	8 1/2"	20"
NOMAD 6032	106667	60"	33" min.	15"	8 1/2"	18"
RUBIX 6032	105705	59 3/4"	32" min.	15"	8 1/2"	18 3/8"
RUBIX 6032 AFR	105704	59 3/4"	32" min.	15"	8 1/2"	20 3/8"

Si vous installez une porte, doubler les montants de bois (2x4) là où les montants muraux seront installés.

Vérifier que les murs soient à l'équerre et verticaux et que le sol est de niveau.

1.1 Cochez-moi!

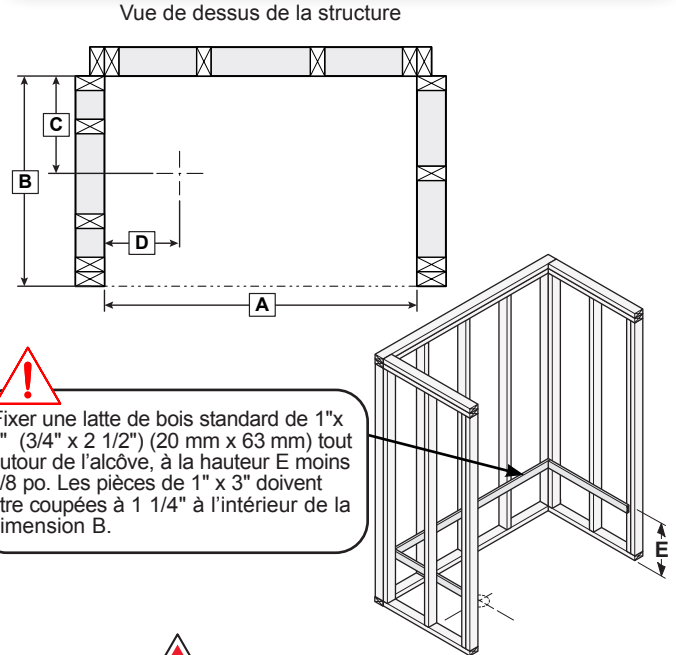

Respecter la position des montants avant et des coins intérieures, les autres peuvent varier.

1.2 Cochez-moi!



1.3 Cochez-moi!

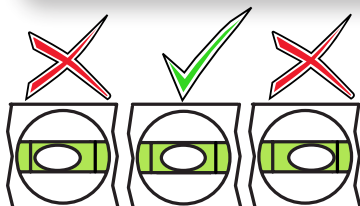
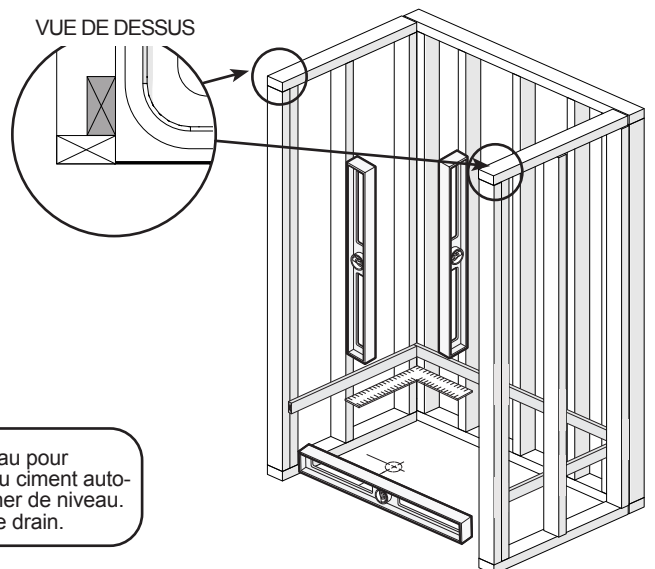

Il est important de mettre le plancher de niveau pour assurer un bon alignement de l'installation. Du ciment auto-nivelant peut être utilisé pour mettre le plancher de niveau. Veillez à ne pas bloquer la position du trou de drain.

Couper une ouverture d'environ 6 po x 6 po pour le drain central, en respectant les mesures C et D. Voir l'image de droite et le tableau de l'étape 1.1. Nous recommandons de faire appel à un plombier certifié pour le raccordement du drain.

1.3
Cochez-moi!

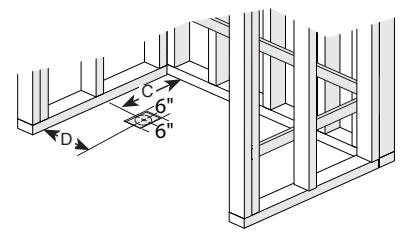

ÉTAPE 2 Installation de la baignoire



Retirer la pellicule transparente sur la baignoire. Utiliser du carton dans le fond de la baignoire comme protection jusqu'à la fin de l'installation.

Mettre la baignoire (13) en place en l'appuyant complètement contre les montants du mur arrière. Centrer la baignoire par rapport aux murs de côté en laissant un espace équivalent de chaque côté.



Il est essentiel de bien centrer la baignoire pour assurer l'installation adéquate des murs de côté.

Effectuer le raccordement de la plomberie (drain, robinet, trop-plein, etc.) selon les normes locales et les règles générales au début du guide de la baignoire.

2.1
Cochez-moi!

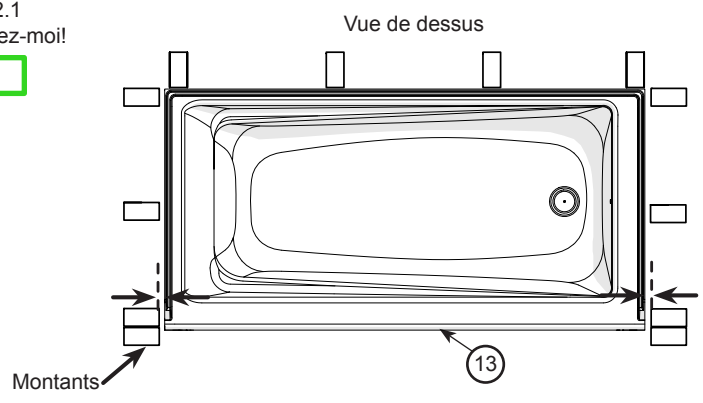

2.2
Cochez-moi!



S'assurer sur tous les côtés que la baignoire est parfaitement de niveau. Vérifier que le drain est aligné.

Nous recommandons de faire appel à un plombier certifié pour le raccordement du drain.

2.3
Cochez-moi!

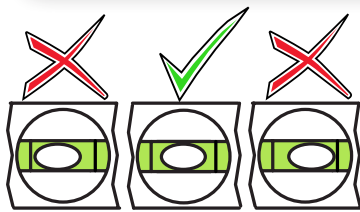
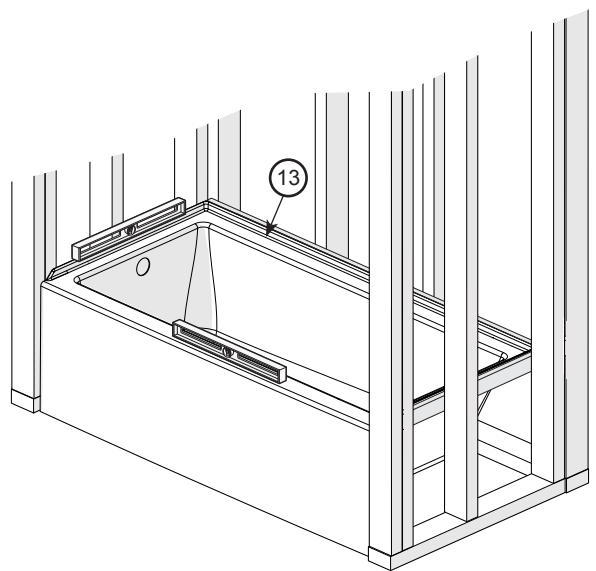

Il est essentiel que la baignoire soit de niveau pour assurer la verticalité des murs.

ÉTAPE 2 Installation de la baignoire (suite)

Au besoin, utiliser des cales de bois entre la baignoire et les montants pour maintenir la baignoire en position centrée.

NE PAS UTILISER DES CALES DE BOIS SOUS LA BAIGNOIRE POUR LA METTRE DE NIVEAU; CELA ANNULERA LA GARANTIE!

2.4
Cochez-moi!

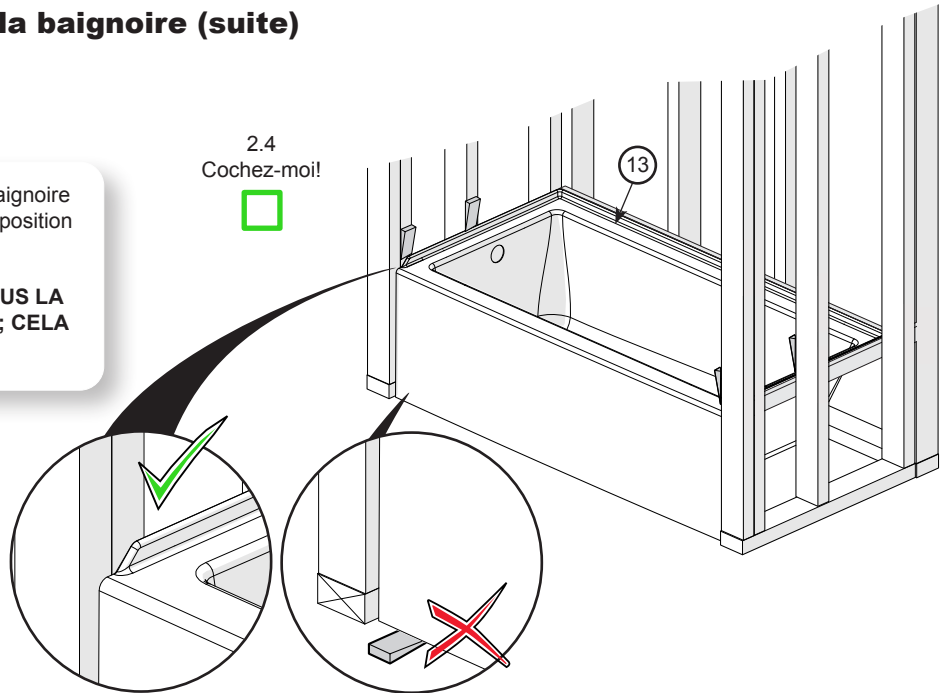

Percer des pré-trous dans la bride de la baignoire seulement, avec une mèche de 1/8 po. **Ne pas percer les montants.** Fixer la baignoire à tous les montants à l'aide de vis #8 x 1-3/4 po (non incluses).

REMPILIR LES TROUS DE SILICONE AVANT VISSER SERRER À LA MAIN SEULEMENT!

COUPER LA PARTIE EXCÉDENTAIRE DES CALES.

2.5
Cochez-moi!

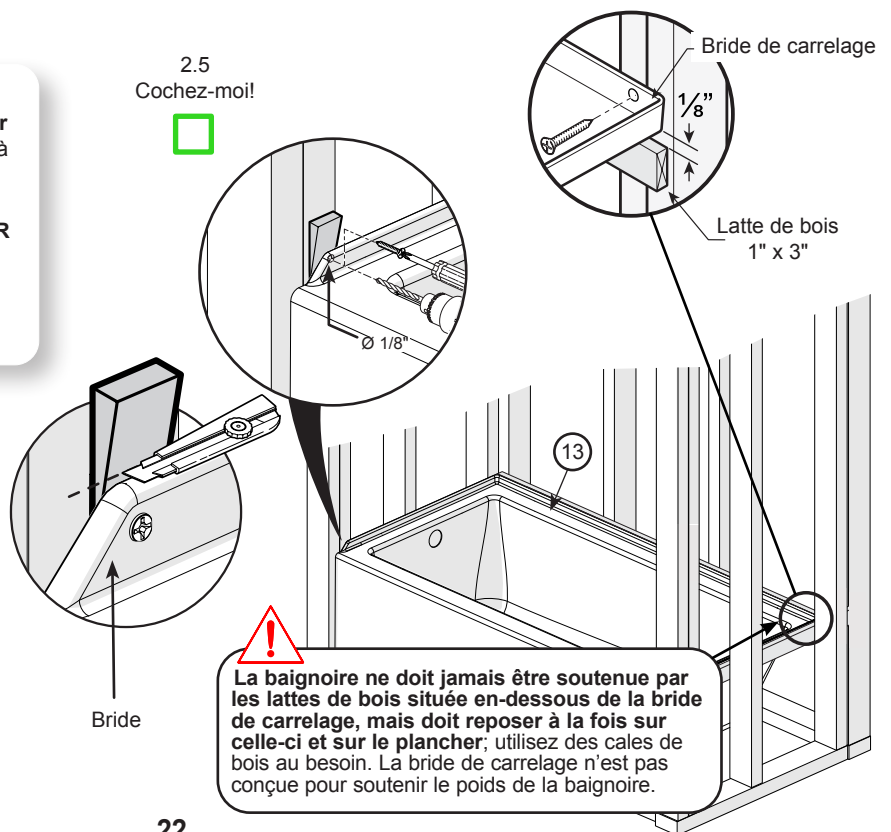

La baignoire ne doit jamais être soutenue par les lattes de bois située en-dessous de la bride de carrelage, mais doit reposer à la fois sur celle-ci et sur le plancher; utilisez des cales de bois au besoin. La bride de carrelage n'est pas conçue pour soutenir le poids de la baignoire.

ÉTAPE 3 Installation du système Ulok sur les murs

 Les pièces du système Ulok se trouvent dans la boîte contenant les murs. (un paquet par mur de côté)

Installer trois fixations en X (1) dans les trous prépercés de chaque côté du mur arrière (14) au moyen des vis fournies (2).

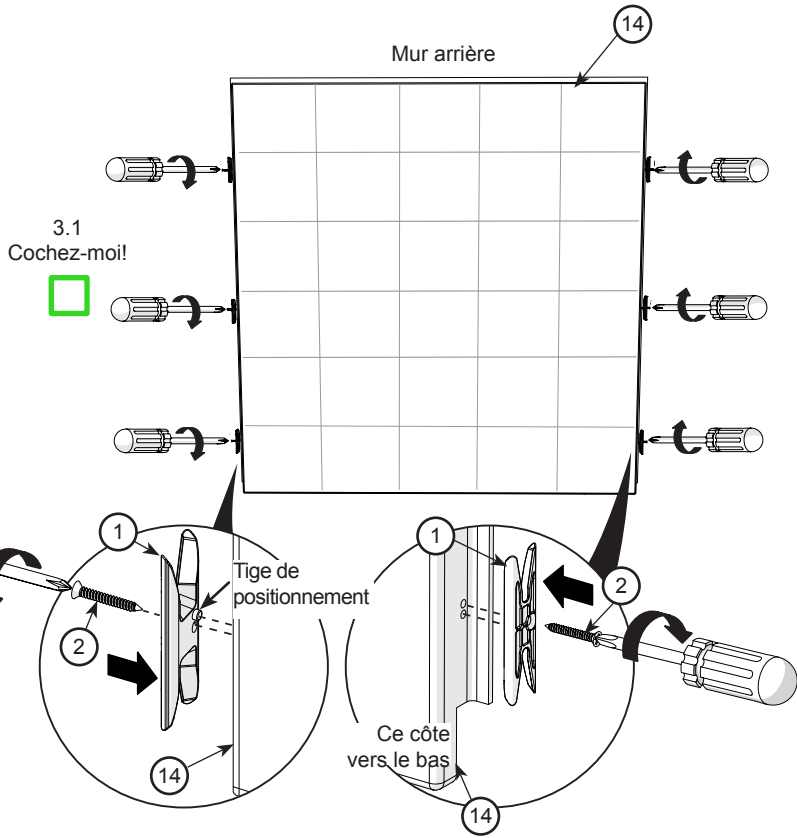

Conseil éclair  Les fixations en X sont dotées d'une tige de positionnement pour aider à leur installation, ils ne s'installent que d'une façon.

Installer trois chevilles d'ancrage (3) par mur de côté dans les trous prépercés, au moyen des vis fournies (4).

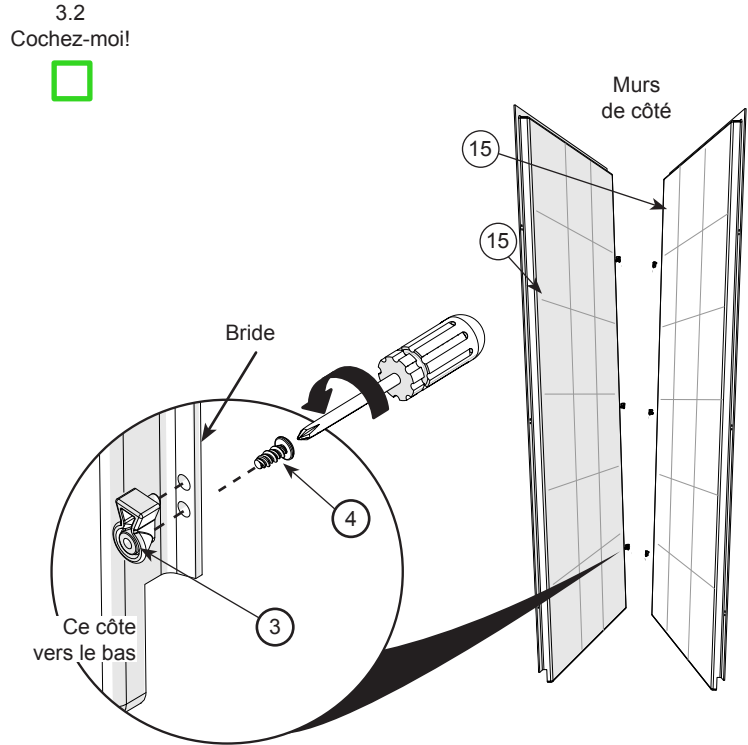

Conseil éclair  Les murs de côté sont interchangeables. Pour le mur de gauche, fixer les chevilles d'ancrages à droite, et pour le mur de droite, fixer les chevilles à gauche.

ÉTAPE 4 Installation temporaire du mur arrière

Retirer au moins 3 ou 4 po de pellicule transparente de **tous les côtés** du mur arrière. Laisser le reste de la pellicule collée sur le mur.

Positionner le mur arrière (14) en le déposant sur le rebord arrière de la baignoire, puis le mettre de niveau.

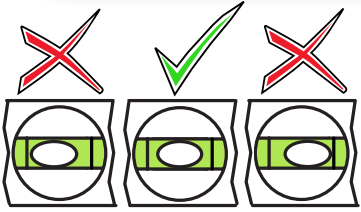

! Il est essentiel de mettre le mur arrière de niveau pour assurer l'alignement des murs de côté.

Conseil éclair



L'installation temporaire des murs permet de s'assurer de leur alignement adéquat avant de procéder à leur installation permanente.

4.1
Cochez-moi!



4.2
Cochez-moi!

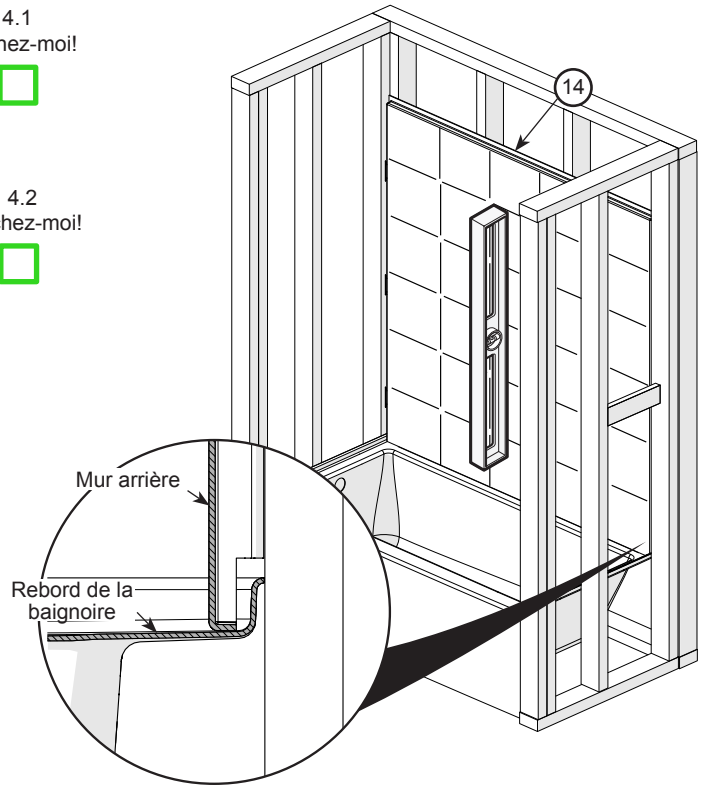

Faire des pré-trous dans la bride du mur arrière seulement (14), vis-à-vis de chaque montant avec une mèche de 1/8 po. **Ne pas percer les montants.** Fixer temporairement le mur arrière à un seul montant à l'aide d'une vis #8 x 1-3/4 po (non incluse).

IMPORTANT : SERRER À LA MAIN SEULEMENT. INSTALLATION TEMPORAIRE.

Conseil éclair



Pousser le bas du mur contre les montants avec le pied au moment de le visser en place.

4.3
Cochez-moi!



min. 3/16"
max. 3/8"

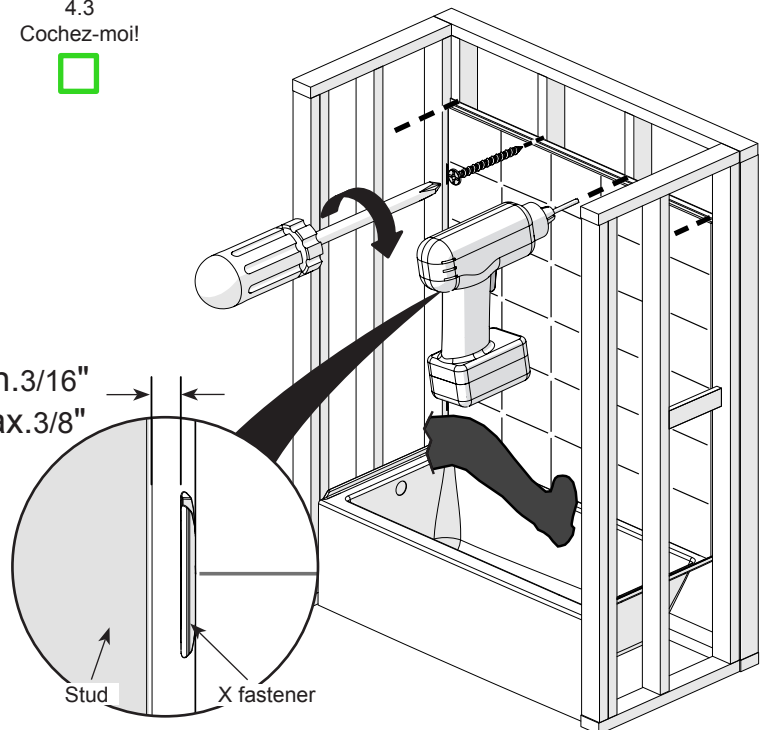

ÉTAPE 5 Installation temporaire des murs de côté

Installer d'abord le mur de côté (15) du côté opposé à la robinetterie. Placer le mur à environ 3 po au-dessus du rebord de la baignoire, le pousser à fond contre le mur arrière, puis l'abaisser sur le rebord de la baignoire.

5.1
Cochez-moi

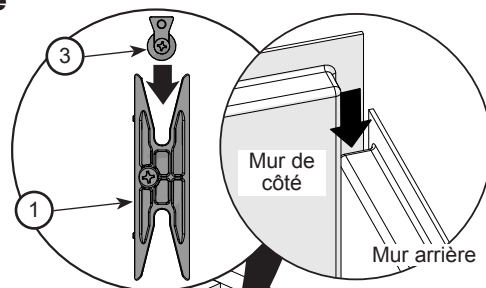

!
Il est essentiel que les chevilles d'ancrage soient bien insérées dans les fixations en X. Il ne devrait y avoir aucun espacement entre le mur de côté et le mur arrière.

Conseil éclair



Le mur de côté devrait être bien aligné avec le devant de la baignoire.

Conseil éclair



Vérifier la verticalité du mur de côté à l'aide d'un niveau. Si le mur n'est pas vertical, s'assurer que les chevilles d'ancrages sont bien insérées dans les fixations en X.

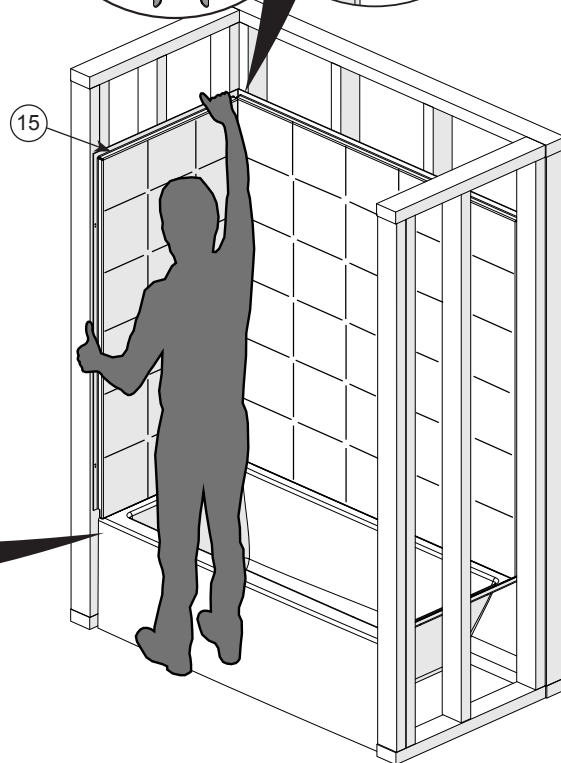
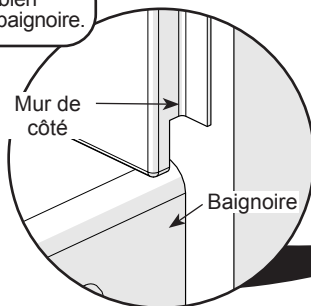

5.2
Cochez-moi!



Faire des pré-trous dans la bride du mur de côté seulement (15), vis-à-vis de chaque montant avec une mèche de 1/8 po. **Ne pas percer les montants.** Fixer temporairement le mur de côté à un seul montant à l'aide d'une vis #8 x 1-3/4 po (non incluse).

IMPORTANT : SERRER À LA MAIN SEULEMENT. INSTALLATION TEMPORAIRE.

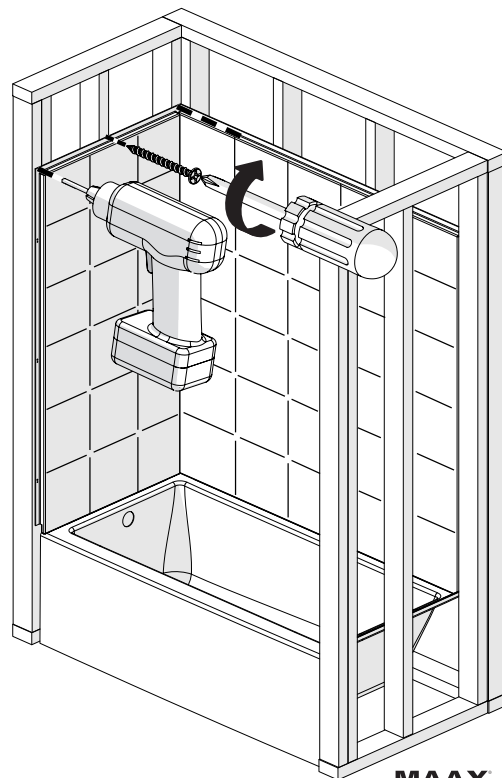

ÉTAPE 5 Installation temporaire des murs de côté (suite)

Mesurer la distance entre la face du mur arrière et le centre de la robinetterie. Mesurer ensuite la distance entre le rebord de la baignoire et le centre de la robinetterie.

Reporter les mesures de la position du trou de la robinetterie sur le mur de côté non installé. Mesurer à partir du bas du mur et du côté des chevilles d'ancrage. Répéter cette étape pour chaque trou de robinetterie.

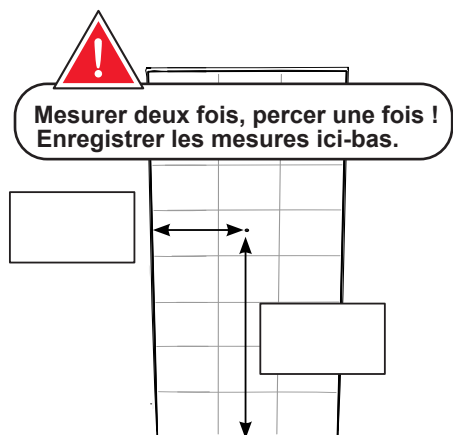

5.3
Cochez-moi!



5.4
Cochez-moi!

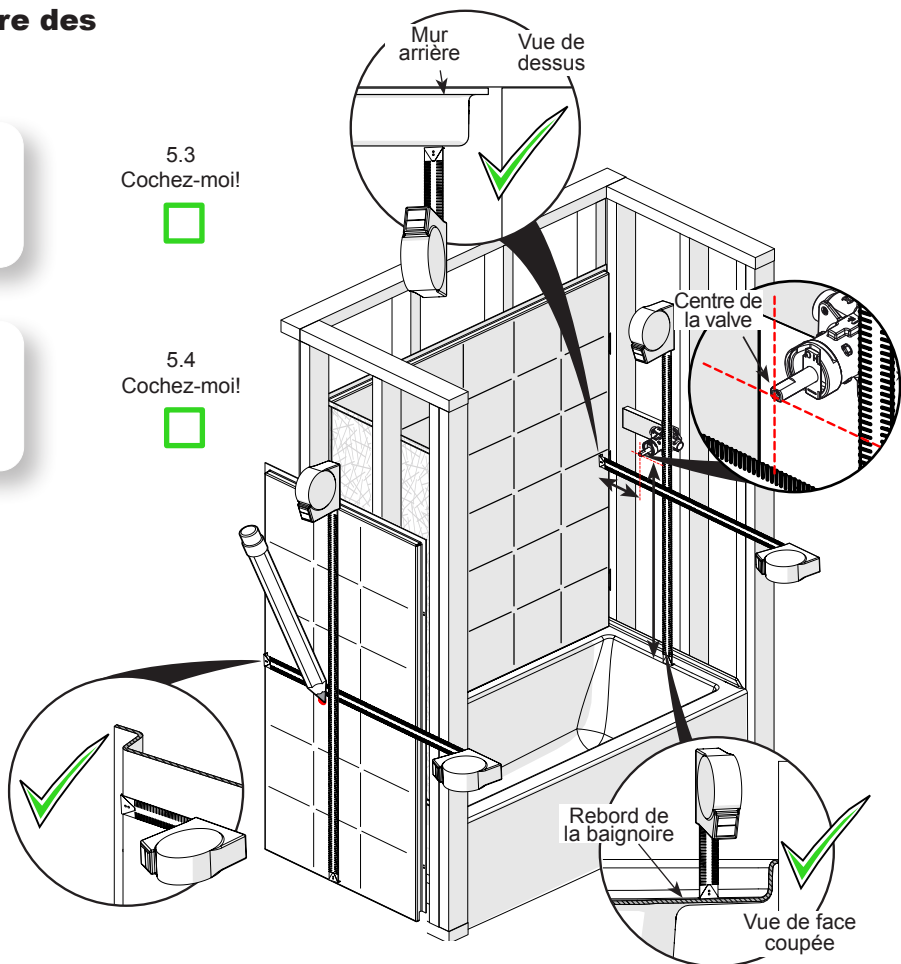

Percer par l'avant les trous pour la robinetterie : Faire d'abord un preperçage à l'aide d'une mèche de 1/8 po. Utiliser une scie-cloche pour percer le trou de la robinetterie à l'endroit marqué. Consulter le guide d'installation de la robinetterie pour connaître la taille nécessaire de la scie-cloche.

Conseil éclair



Les scies-cloches peuvent être louées dans les quincailleries ou les commerces de location d'outils.

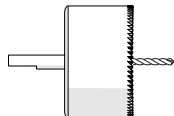

Pour un perçage en toute sécurité : Toujours prepercer un trou et porter des lunettes de sécurité lors du perçage.

5.5
Cochez-moi!

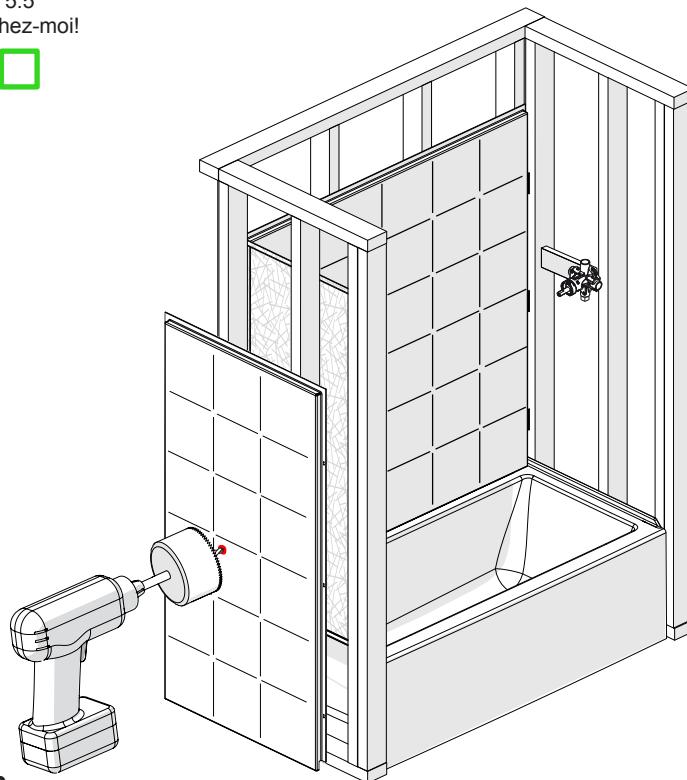

ÉTAPE 5 Installation temporaire des murs de côté (suite)

Installer le mur de côté (15) une fois le/les trou(s) de robinetterie percé(s). Placer le mur à environ 3 po au-dessus du rebord de la baignoire, le pousser à fond contre le mur arrière, puis l'abaisser sur le rebord de la baignoire.



Il est essentiel que les chevilles d'ancrage soient bien insérées dans les fixations en X. Il ne devrait y avoir aucun espacement entre le mur de côté et le mur arrière.

Conseil éclair



Le mur de côté devrait être bien aligné avec le devant de la baignoire.

Conseil éclair



Vérifier la verticalité du mur de côté à l'aide d'un niveau. Si le mur n'est pas vertical, s'assurer que les chevilles d'ancrage sont bien insérées dans les fixations en X.

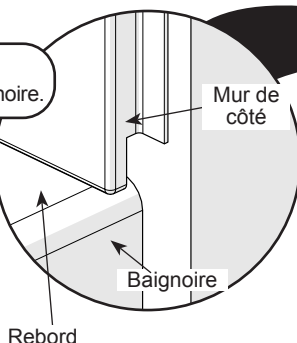

5.6
Cochez-moi!

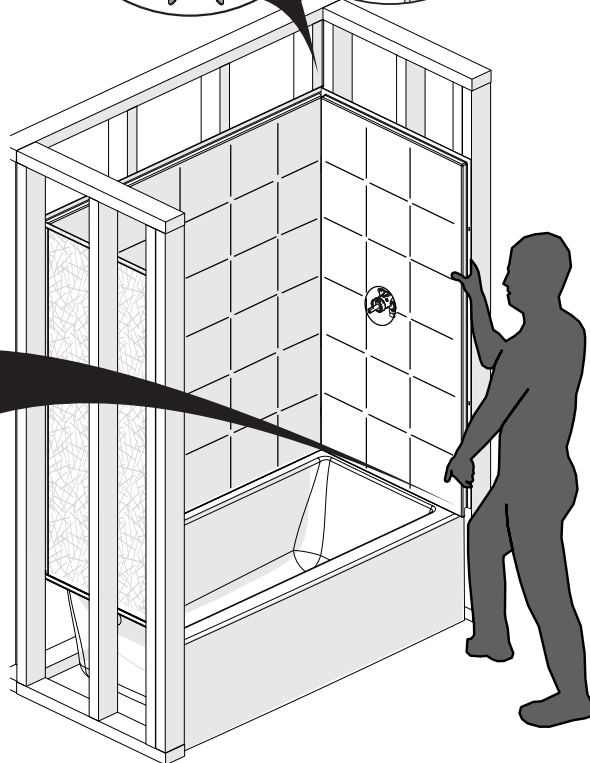
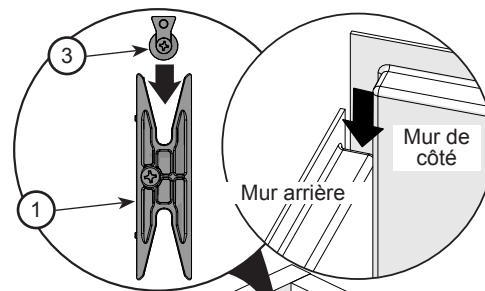

Faire des pré-trous dans la bride du mur de côté (15) seulement, vis-à-vis de chaque montant avec une mèche de 1/8 po. **Ne pas percer les montants.** Fixer temporairement le mur de côté à un seul montant à l'aide d'une vis #8 x 1-3/4 po (non incluse).

IMPORTANT : SERRER À LA MAIN SEULEMENT. INSTALLATION TEMPORAIRE.

5.7
Cochez-moi!

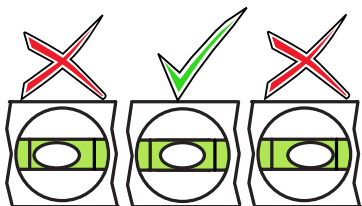
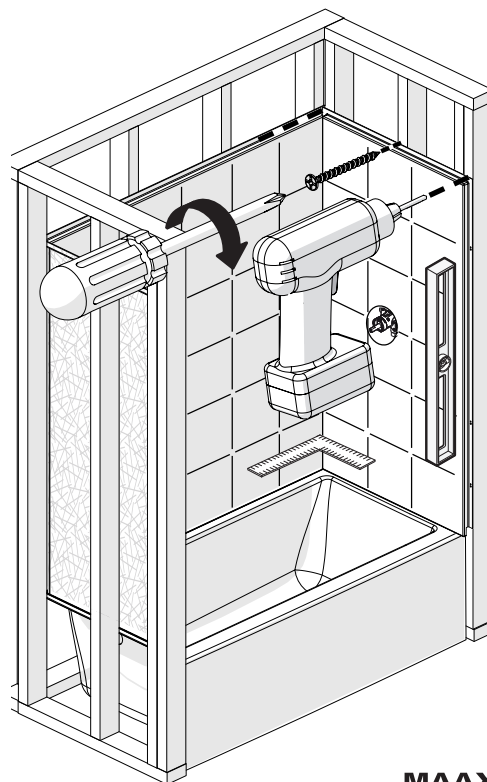

AVANT DE POURSUIVRE, S'ASSURER QUE TOUS LES MURS SONT À L'ÉQUERRE ET VERTICAUX.

5.8
Cochez-moi!



ÉTAPE 6 Installation finale du mur arrière

Retirer tous les murs de la structure.

Nettoyer la baignoire et appliquer un trait de silicone sur le rebord de la baignoire à 3/8 po de la bride arrière. Appliquer de la silicone sur toute la longueur arrière ainsi que sur 1 po de chaque côté.

Soulever et mettre en place le mur arrière (sans le glisser) directement sur la silicone. S'assurer que le mur arrière (14) est de niveau, ajouter des cales de bois au besoin. Fixer le mur arrière à tous les montants à l'aide de vis #8 x 1-3/4 po (non incluses).

IMPORTANT : SERRER À LA MAIN UNIQUEMENT. NE PAS TROP SERRER LES VIS.



Pour assurer l'installation des murs de côté, il doit y avoir un espace minimal de 3/16 po et maximal de 3/8 po entre les montants et les fixations en X.

Conseil éclair



Pousser le bas du mur contre les montants avec le pied lors du vissage.

De chaque côté de la baignoire (13), appliquer un trait de silicone sur toute la longueur du rebord, à 1/4 po de la bride.

Appliquer aussi un trait de silicone sur toute la hauteur du mur arrière (14), sur la surface avant et au bord de l'arrondi. **À la jonction du mur arrière et de la baignoire, les traits de silicone doivent se chevaucher.**

6.1
Cochez-moi!



6.2
Cochez-moi!

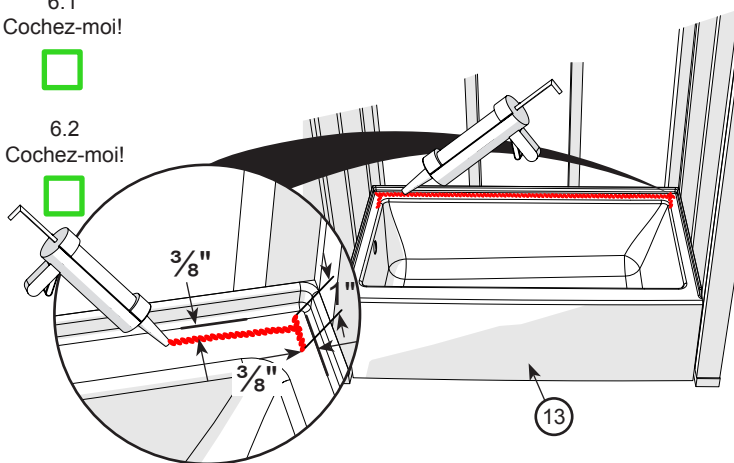

6.3
Cochez-moi!



min. 3/16"
max. 3/8"

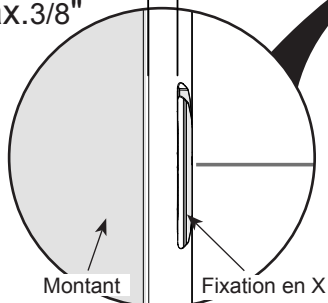

6.4
Cochez-moi!

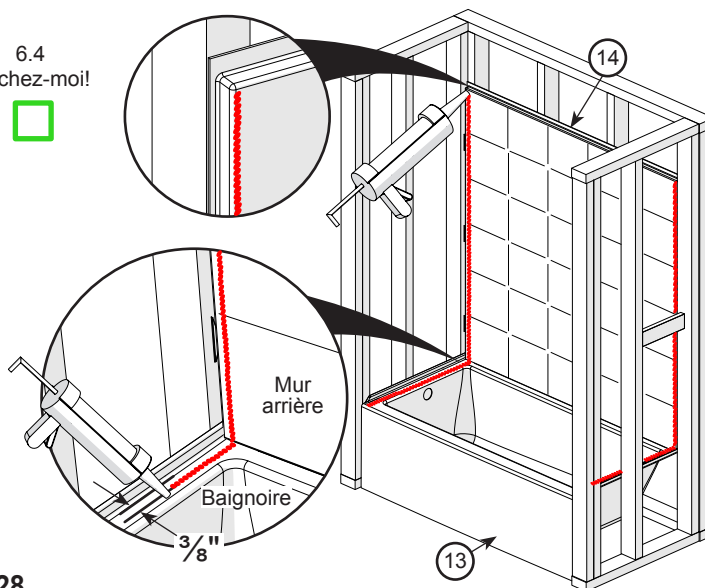

ÉTAPE 7 Installation finale des murs de côté

Installer le mur de côté (15) opposé à celui de la robinetterie. Placer le mur à environ 3 po au-dessus du rebord de la baignoire, le pousser à fond contre le mur arrière, puis l'abaisser sur le rebord de la baignoire.

ENLEVER L'EXCÉDANT DE SILICONE.

7.1
Cochez-moi!

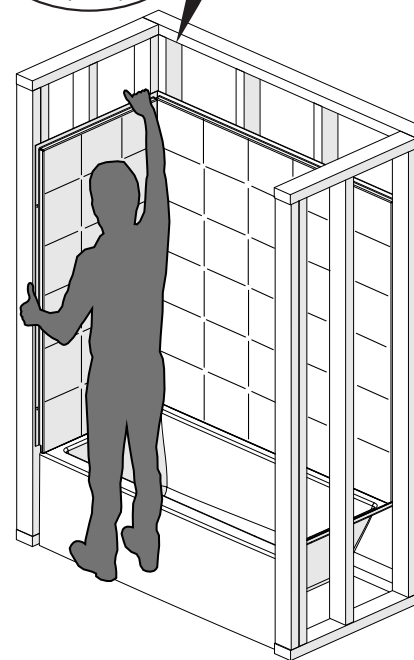
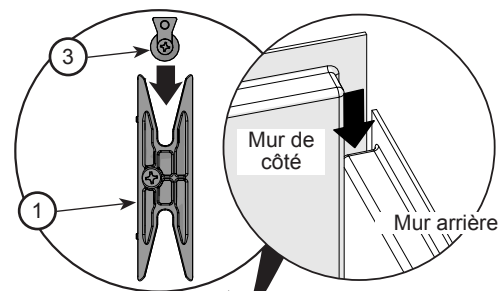

Installer le mur de côté (15) doté de trou(s) de robinetterie. Placer le mur à environ 3 po au-dessus du rebord de la baignoire, le pousser à fond contre le mur arrière, puis l'abaisser sur le rebord de la baignoire.

ENLEVER L'EXCÉDANT DE SILICONE.

7.2
Cochez-moi!

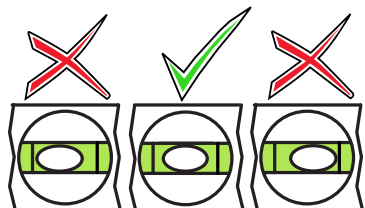
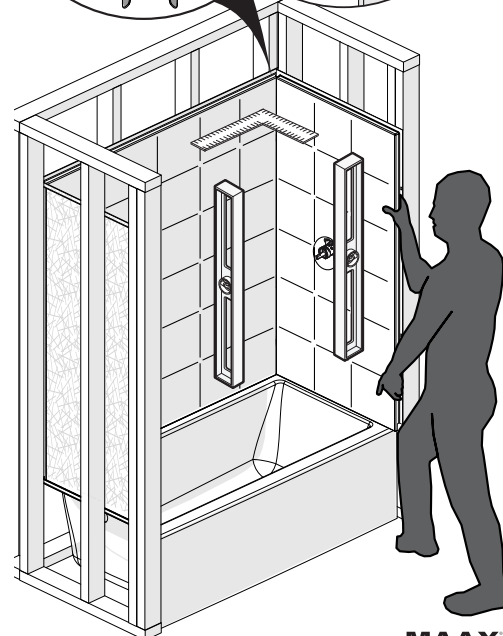
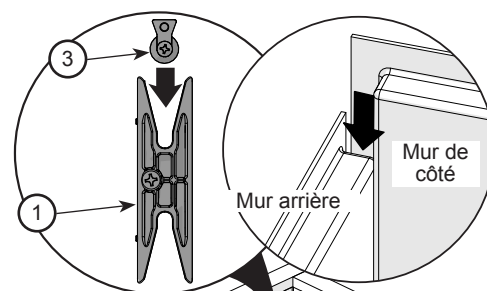

AVANT DE POURSUIVRE, S'ASSURER QUE TOUS LES MURS SONT À L'ÉQUERRE ET VERTICAUX.

7.3
Cochez-moi!



ÉTAPE 7 Installation finale des murs de côté (suite)

Fixer les murs arrière et de côté à tous les montants à l'aide de vis #8 x 1-¼ po (non incluses). Visser les murs de côté en utilisant les avant-trous de la bride. Au besoin, utiliser des cales de bois pour assurer que les murs sont de niveau et verticaux. (Couper l'excédant des cales)

IMPORTANT : SERRER À LA MAIN UNIQUEMENT. NE PAS TROP SERRER LES VIS.

Conseil éclair



LES MURS DE CÔTÉ DEVRAIENT ÊTRE BIEN ALIGNÉS AVEC LA BAIGNOIRE.

Mur de côté

Baignoire

7.4
Cochez-moi!

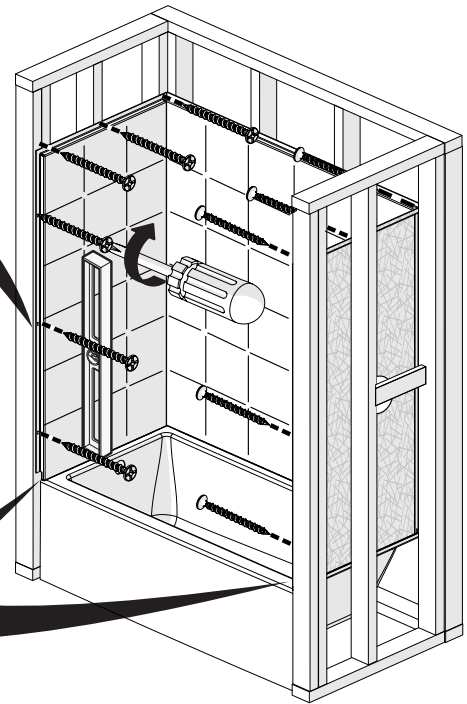
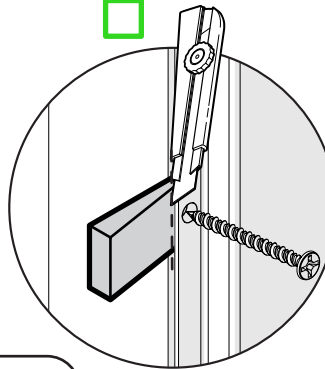

ÉTAPE 8 Marquage et perçage des trous pour la tablette

Placer le gabarit de la tablette dans le coin de la douche, à l'endroit désiré. Glisser le gabarit jusqu'à ce que les trous soient à la hauteur désirée de la tablette. Marquer l'emplacement des trous de perçage. Percer les trous avec une mèche de 6/64 po.

Cochez-moi!

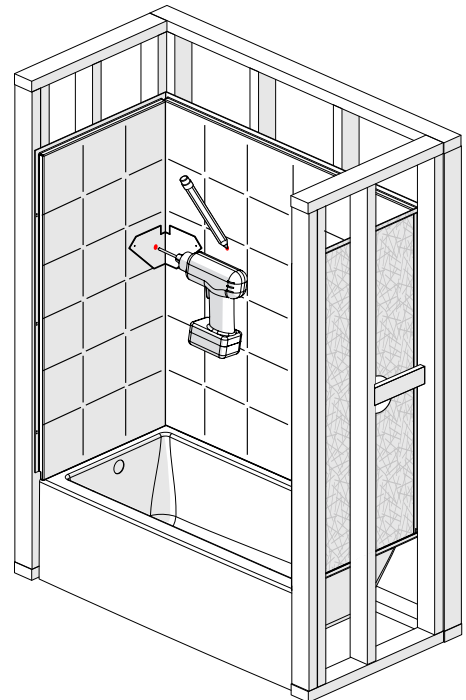
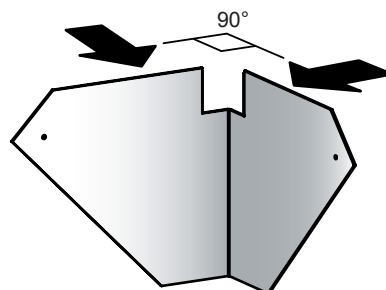
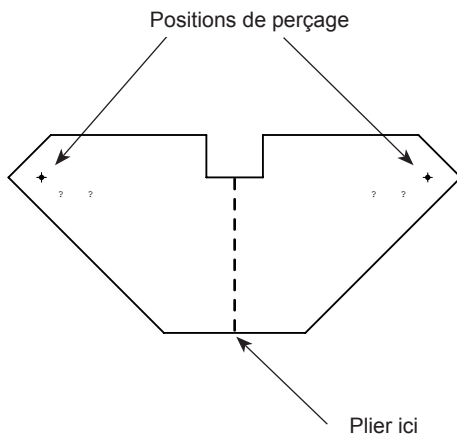

ÉTAPE 9 Silicone

Appliquer un trait de silicone sur toute la longueur des joints (mur à mur et mur à baignoire). Pour une belle finition, enlever l'excédant de silicone avec un chiffon humide ou un doigt mouillé.

Conseil éclair



Appliquer du ruban-cache de chaque côté du joint où le trait de silicone sera appliqué. Appliquer la silicone, lisser avec un doigt mouillé, puis enlever le ruban-cache.

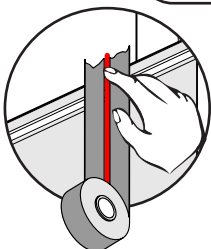

Toute robinetterie installée sur les murs doit être scellée avec de la silicone.

Cochez-moi!



Enlever la pellicule protectrice des murs

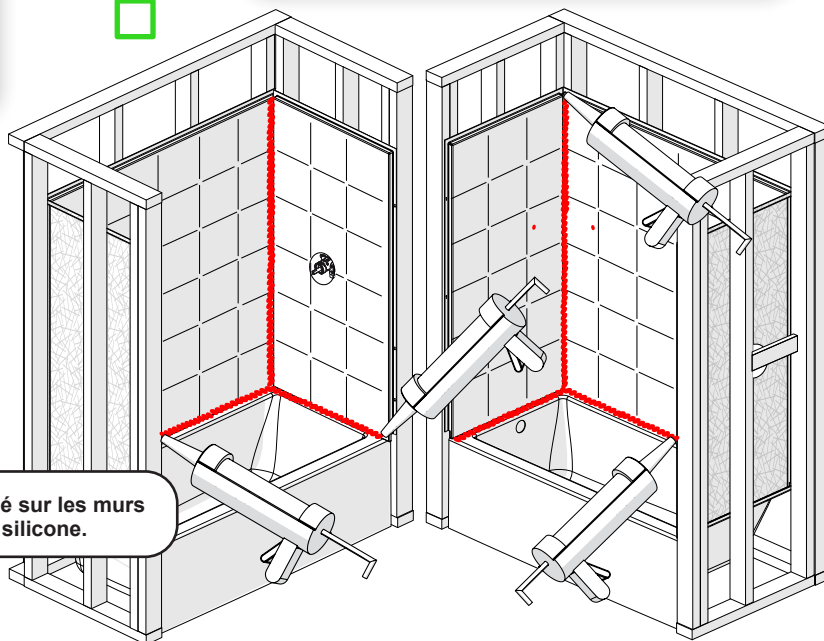

ÉTAPE 10 Installation de la tablette

Appliquer de la silicone dans les trous du mur de côté et arrière qui serviront à l'installation de la tablette. Appliquer de la silicone sur l'arrière des supports (6). Fixer les supports aux murs en utilisant les vis fournies (7).

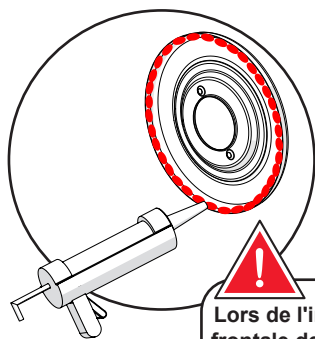

Lors de l'installation de la plaque frontale de la valve ou d'autres composants, appliquer du silicone sur le bord extérieur.

10.1
Cochez-moi!

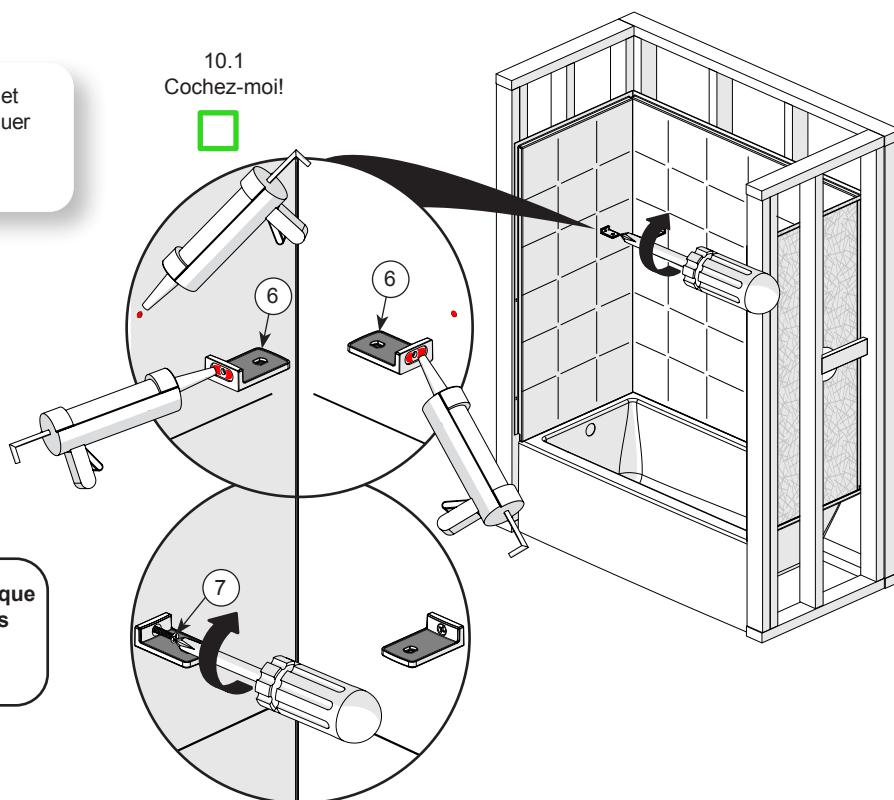

ÉTAPE 10 Installation de la tablette (suite)

Nettoyer la partie en caoutchouc sur le dessus des supports avec un chiffon humide. Placer ensuite la tablette (5) sur les supports (6).

Conseil éclair



La tablette est sur le bon côté s'il est possible de lire le logo MAAX.

10.2
Cochez-moi!

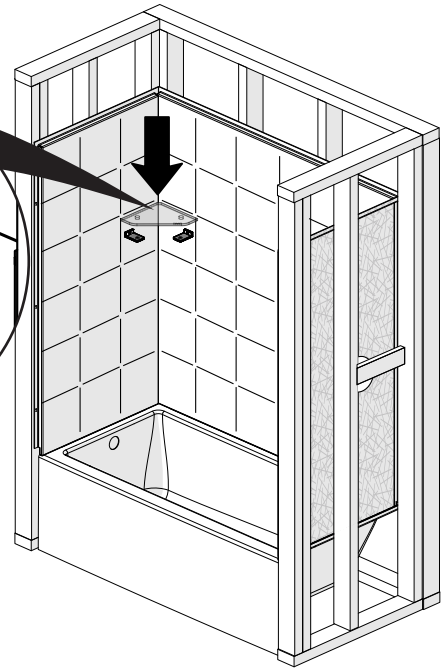
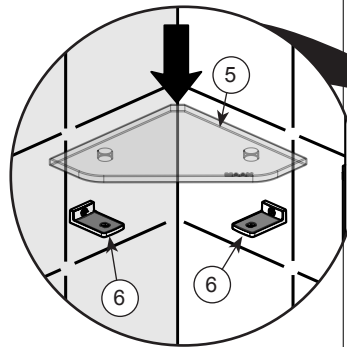

Insérer les capuchons (9) dans les rondelles (8). Aligner les trous de la tablette et ceux des supports (6), puis y insérer l'assemblage du capuchons (9). Sous la tablette, insérer les vis #10 x 1/2 po (10) et serrer avec la clé hexagonale (11).

10.3
Cochez-moi!

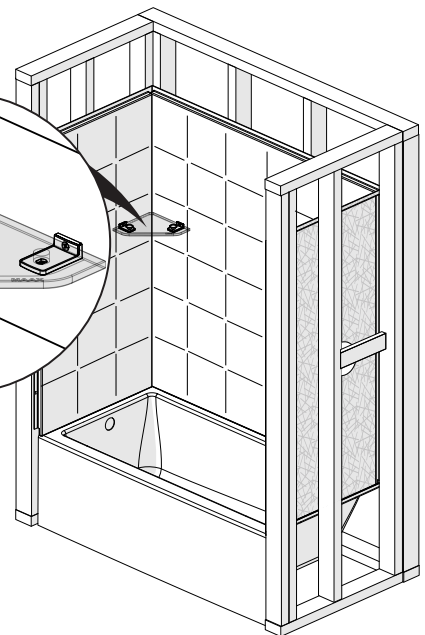
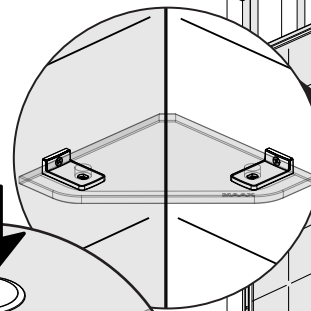
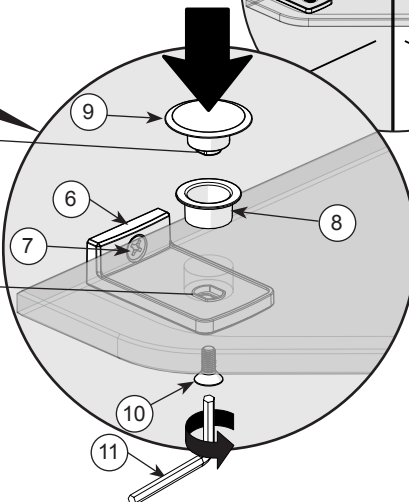
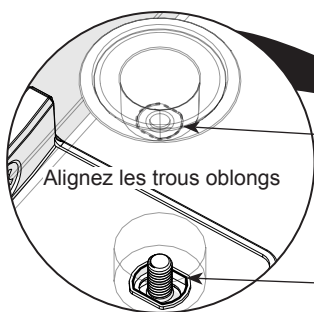

Ne pas trop serrer le capuchon (9)

ÉTAPE 11 Finition du mur

Cochez-moi!



Pour la finition du mur, vous pouvez installer votre matériel de finition sur le dessus de la bride ou sur le bord de mur, comme indiqué.

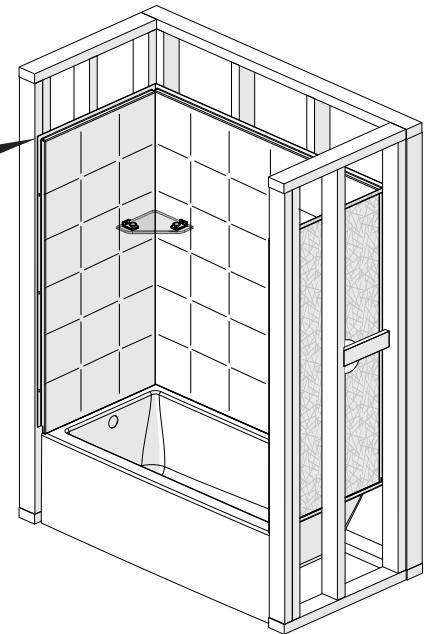
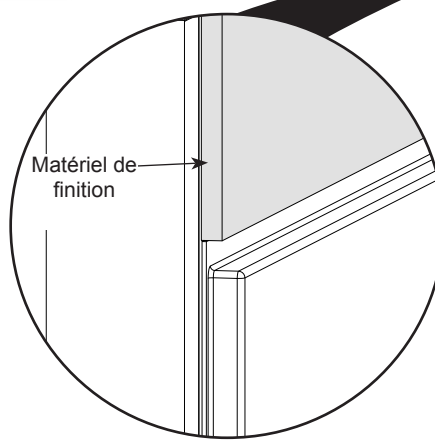
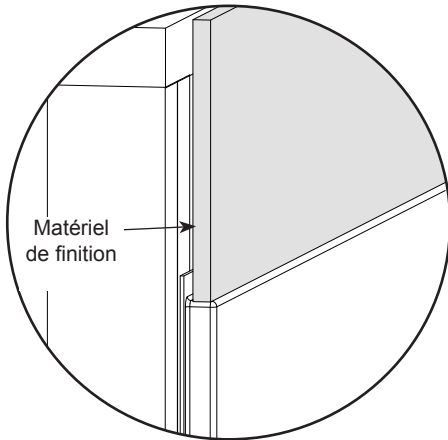

Conseils d'entretien

MAAX conçoit et fabrique ses produits avec des **matériaux durables de haute qualité et des technologies d'avant-garde** dans le but de réduire le temps de nettoyage et d'entretien. Néanmoins, il demeure essentiel de les entretenir de façon régulière et adéquate. Voici des conseils généraux d'utilisation et d'entretien, qui s'ajoutent aux recommandations spécifiques à votre produit MAAX. Nous vous recommandons de les suivre pour bénéficier de nombreuses années d'agréable utilisation.

Entretien de murs U tile / baignoire / base de douche / porte de douche

- ☒ Nettoyer régulièrement avec un nettoyant à vaporiser ou en crème non-abrasif.
- ☒ Ne jamais utiliser de nettoyants pour tuiles ou joints de coulis. Ces produits sont inappropriés aux produits U tile et pourraient endommager l'unité.
- ☒ Ne jamais utiliser un nettoyant abrasif, un grattoir, une brosse métallique ni tout outil ou produit qui peut rayer ou ternir la surface de votre unité MAAX.
- ☒ Afin d'éviter d'endommager le fini de l'unité, retirer les résidus de plâtre qui pourraient se déposer sur les surfaces lors de travaux avec une spatule en plastique ou en bois enveloppée dans un chiffon humide.
- ☒ Essuyer la porte de douche après chaque utilisation avec une raclette ou un chiffon doux afin de réduire l'accumulation de savon, d'additifs de bain, d'huiles corporelles naturelles et de minéraux présents dans l'eau. Cela facilite le nettoyage et aide à maintenir le lustre naturel de votre produit.
- ☒ Réparer les fissures ou les dommages immédiatement au moyen de la trousse de réparation MAAX pour les produits U tile. Pour plus d'information, contactez le service à la clientèle au 1-877-GET-MAAX (1-877-438-6229).



Para una instalación sin problemas siga las etapas una a una y marque una vez finalizada cada etapa.



ETAPA 1 Construcción de la estructura

Antes de comenzar asegúrese de tener todas las piezas y componentes referirse a la página 4.

Construir una estructura que respete las dimensiones mencionadas en la tabla.

SI LA ESTRUCTURA YA ESTA CONSTRUIDA, ASEGURARSE QUE LAS DIMENSIONES RESPETEN LAS DE LA TABLA

BAÑERAS COMPATIBLES	No	A	B	C	D	E
AVENUE 6030	102576 105927	59 7/8"	31"	13 5/8"	8 3/8"	20 1/4"
BOSCA 6030	106394	59 3/4"	30" min.	14"	8 1/2"	18 3/8"
BOSCA 6030 AFR	106395	59 3/4"	30" min.	14"	8 1/2"	20 3/8"
COCOON 6030 IFS	105822	Between 60" - 60 1/4"	31 1/2" min.	14 1/8"	9 3/8"	19 5/8"
BROME	105821	Between 60" - 60 1/4"	31 1/2" min.	14 1/8"	9 3/8"	19 5/8"
EXHIBIT 6030 (IFS)	105519	59 3/4"	30" min.	14"	10"	17 3/8"
EXHIBIT 6030 (IFS) AFR	105511	59 3/4"	30" min.	14"	10"	19 3/8"
NEW TOWN 6030 IFS	105454	59 3/4"	30" min.	14"	10"	19 3/8"
NOMAD 6030 AFR	106662	60"	31" min.	14"	8 1/2"	20"
NOMAD 6030	106663	60"	31" min.	14"	8 1/2"	18"
RUBIX 6030	105815	59 3/4"	30" min.	14"	8 1/2"	18 3/8"
RUBIX 6030 AFR	105816	59 3/4"	30" min.	14"	8 1/2"	20 3/8"
RUBIX ACCESS 6030 IFS	106348	59 7/8"	30" min.	14 1/4"	8 1/2"	18 3/8"
RUBIX ACCESS 6030 IFS AFR	106349	59 7/8"	30" min.	14 1/4"	8 1/2"	20 3/8"

BAÑERAS COMPATIBLES	No	A	B	C	D	E
EXHIBIT 6032 (IF)	105514 105550	59 3/4"	32" min.	16"	10"	20"
EXHIBIT 6032 (IFS) AFR	105512 105548	59 3/4"	32" min.	15"	10"	19 3/8"
EXHIBIT 6032 IFS	105520 105549	59 3/4"	32" min.	15"	10"	17 5/8"
JAXI 6032	106883	60"	33" min.	16"	8 1/2"	17 3/4"
MACKENZIE 6032 AFR	106668	60"	33" min.	15"	8 1/2"	20"
MACKENZIE 6032	106669	60"	33" min.	15"	8 1/2"	18"
NEW TOWN 6032 IF	105467	59 3/4"	32" min.	16"	10"	20"
NEW TOWN 6032 IFS	105456	59 3/4"	32" min.	15"	10"	19 3/8"
NOMAD 6032 AFR	106666	60"	33" min.	15"	8 1/2"	20"
NOMAD 6032	106667	60"	33" min.	15"	8 1/2"	18"
RUBIX 6032	105705	59 3/4"	32" min.	15"	8 1/2"	18 3/8"
RUBIX 6032 AFR	105704	59 3/4"	32" min.	15"	8 1/2"	20 3/8"

Si está instalando una puerta, duplicar los montantes (2x4) en los lugares en los que se instalarán las jambas murales.

Verificar que los listones estén a escuadra y verticales y que el piso esté a nivel.

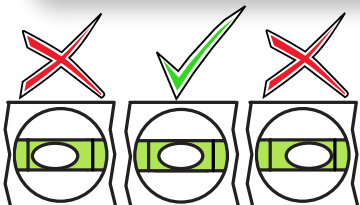

MAAX



Es esencial que el suelo esté a nivel para garantizar una instalación alineada. Cemento autonivelante puede ser usado para nivelar el piso. Tenga cuidado de no bloquear la posición de la abertura del desagüe.

INSPECCIÓN VISUAL FINAL
Nota: No hacerlo podría anular la garantía

Después de quitar la película protectora y antes de completar la instalación, realice una inspección visual. Si hay defectos visibles, **INTERRUMPA LA INSTALACIÓN** y comuníquese con nuestro servicio al cliente: 1-877-438-6229

Vista superior de la estructura

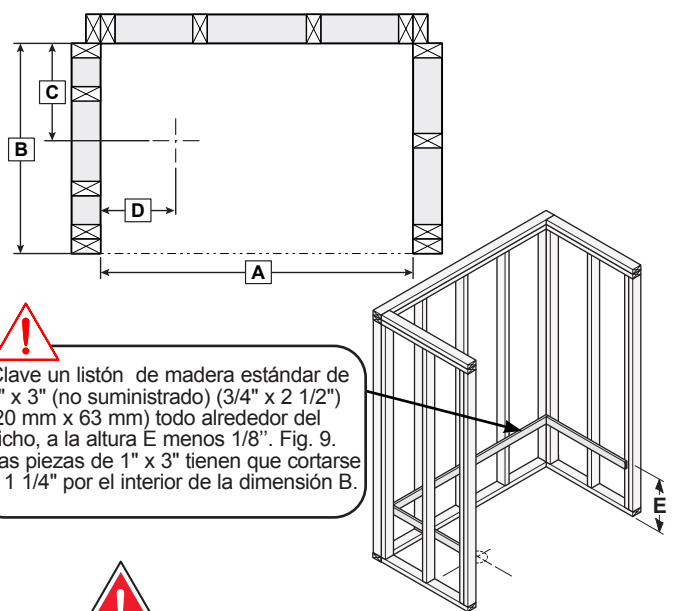

Respetar la posición de los montantes al frente y en las esquinas interiores, los otros pueden variar.

VISTA SUPERIOR

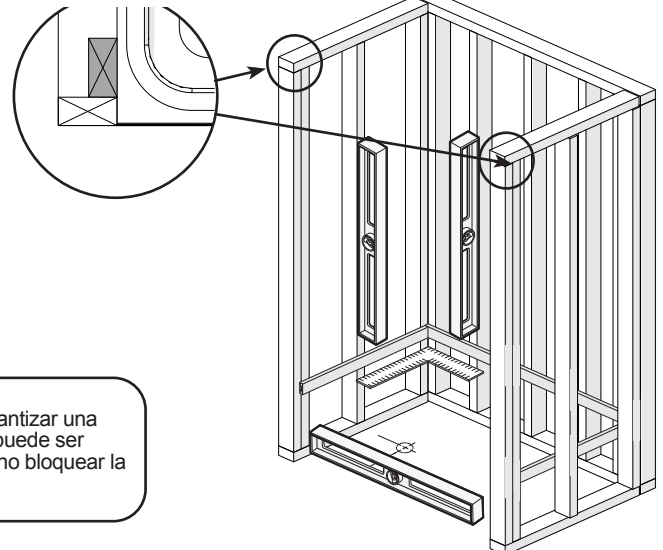

1.1 Marcarme!



1.2 Marcarme!



1.3 Marcarme!



Corte una abertura de aproximadamente 6 x 6 para el desagüe central, siguiendo las medidas C y D. Ver la imagen de la derecha y de la tabla en el paso 1.1. Recomendamos contratar a un plomero certificado para conectar el desagüe.

1.3
Marcarme!

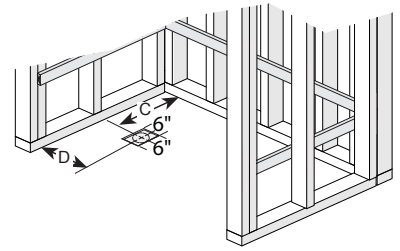

ETAPA 2 Instalación de la bañera



Retire la película transparente de la bañera. Utilice cartón en el fondo de la bañera como protección hasta el final de la instalación.

Ponga la bañera (13) en su lugar apoyandola contra los montantes o listones de la pared del fondo. Centre la bañera con respecto a las paredes laterales dejando un espacio equivalente a cada lado.



Es esencial centrar muy bien la bañera para asegurar la correcta instalación de las paredes laterales.

2.1
Marcarme!

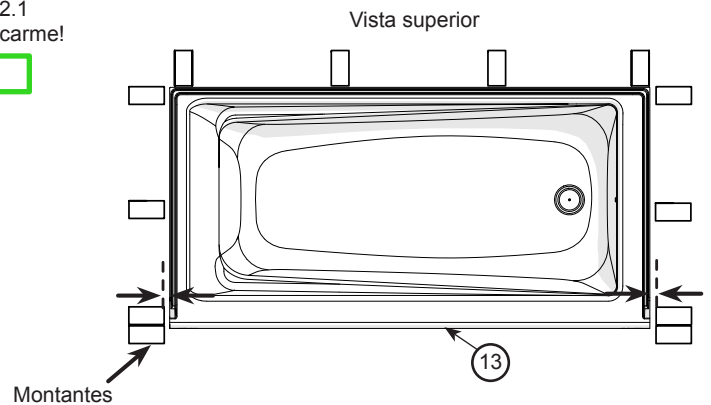

Realizar la conexión de la tubería (desagüe, grifo, desbordamiento, etc.) de acuerdo con las normas locales y las reglas generales al principio de la guía de la bañera.

2.2
Marcarme!



Asegúrese en todos los lados que la bañera esta perfectamente nivelada. Comprobar que el desagüe está alineado.

Se recomienda utilizar una plomero certificado para la conexión de drenaje.

2.3
Marcarme!

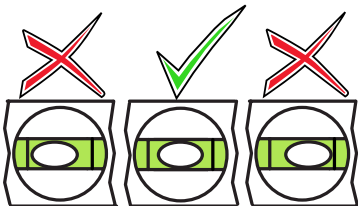
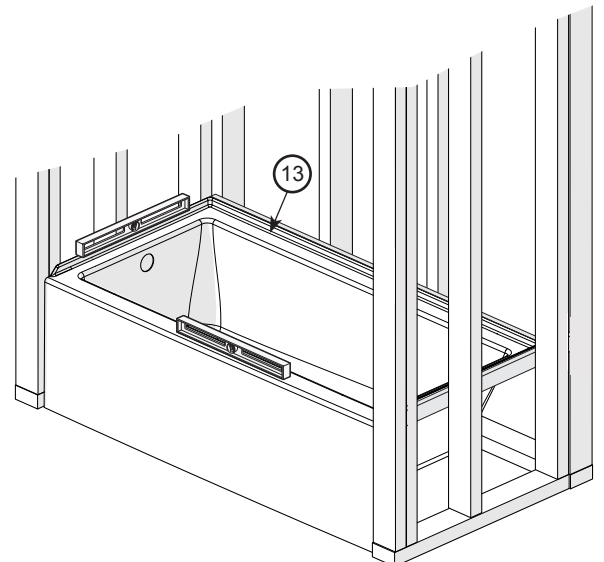

Es esencial que la bañera este a nivel para garantizar la verticalidad de las paredes.

ETAPA 2

Instalación de la bañera (continuación)

Si es necesario, utilizar cuñas de madera entre la bañera y los montantes para mantener la bañera en una posición centrada.

NO USAR CUÑAS DE MADERA DEBAJO DE LA BAÑERA PARA NIVELARLA; HACERLO ANULARÁ LA GARANTÍA!

2.4
Marcarme!

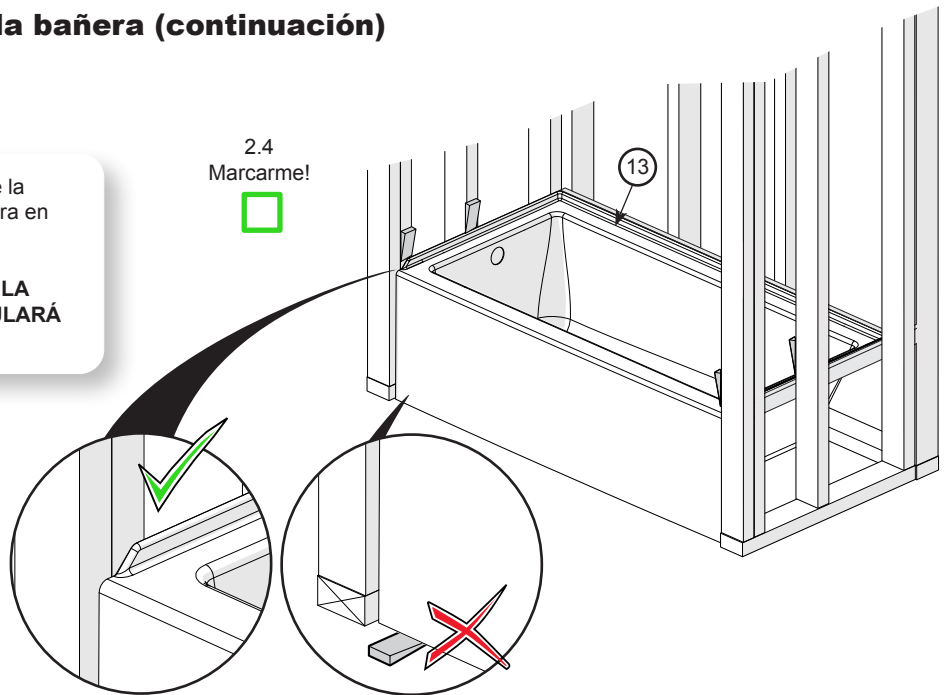

Perforar los pre-agujeros de la brida de la bañera solamente con una broca de 1/8". **No perforar los montantes.** Fijar la bañera a todos los montantes usando tornillos # 8 x 1 3/4" (no incluidos).

LLENAR LOS AGUJEROS DE SILICONA ANTES DE ATORNILLAR

APRETAR A MANO ÚNICAMENTE!

CORTAR EL EXCEDENTE DE LAS CUÑAS.

2.5
Marcarme!

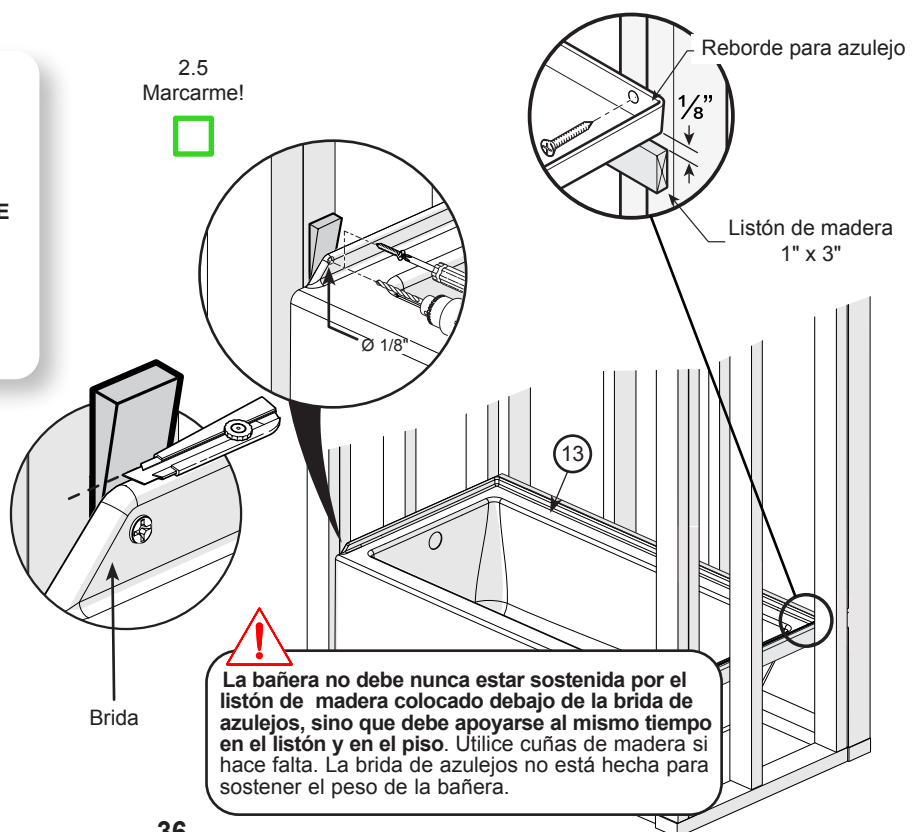

ETAPA 3 **Instalación del sistema Ulok sobre los muros**

 Las piezas del sistema Ulok se encuentran en las cajas de los muros laterales (un paquete por caja)

Instalar tres sujetadores en forma de X (1) en los agujeros preperforados a cada lado del muro posterior (14) con los tornillos suministrados (2).

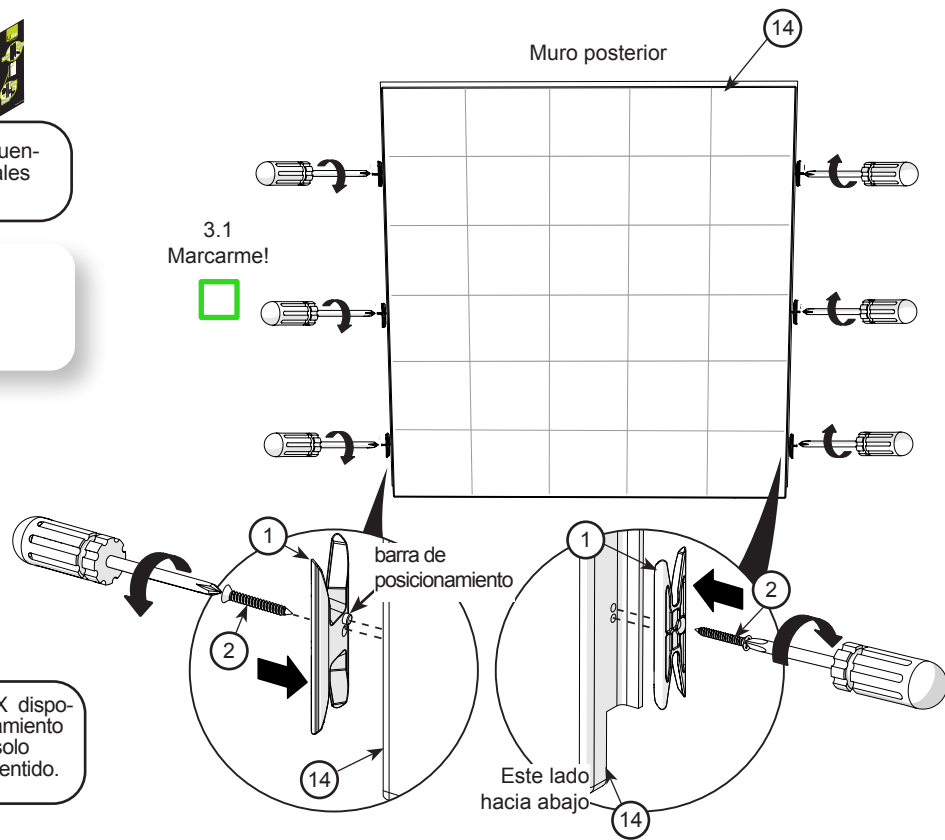

Consejo rápido  Los sujetadores en forma de X disponen de una barra de posicionamiento para ayudar a su instalación, solo pueden ser instalados en un sentido.

Instalar tres pasadores de retracción (3) por cada pared lateral en los agujeros pre-perforados utilizando los tornillos suministrados (4).

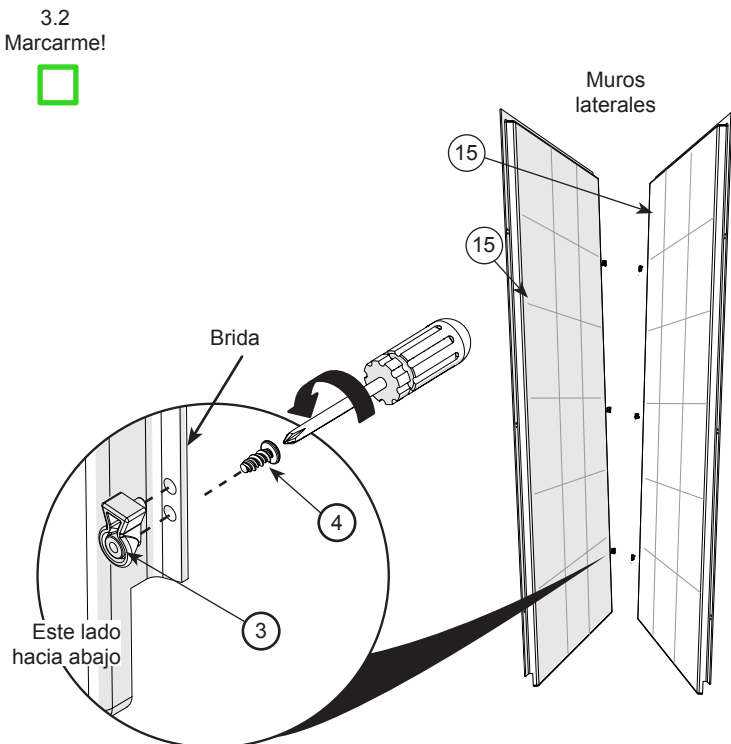

Consejo rápido  Los muros laterales son intercambiables. Para el muro izquierdo, fijar los pasadores a la derecha, y para el muro derecho, fijar los pasadores a la izquierda.

ETAPA 4 Instalación temporal del muro posterior

Retirar al menos 3 o 4 pulgadas de película transparente de todos los lados de la pared posterior. Deje el resto de la película adherida a la pared.

Coloque el muro posterior (14) apoyándolo en el reborde posterior de la bañera y nivelarlo.

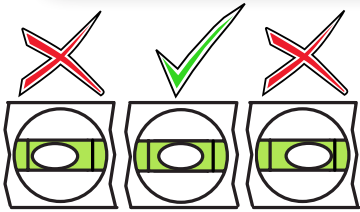

! Es esencial nivelar el muro posterior para garantizar el alineamiento de los muros laterales.

Consejo rápido



La instalación temporal de los muros garantiza su alineación correcta antes de instalarlos de manera permanente.

4.1 Marcarme!



4.2 Marcarme!

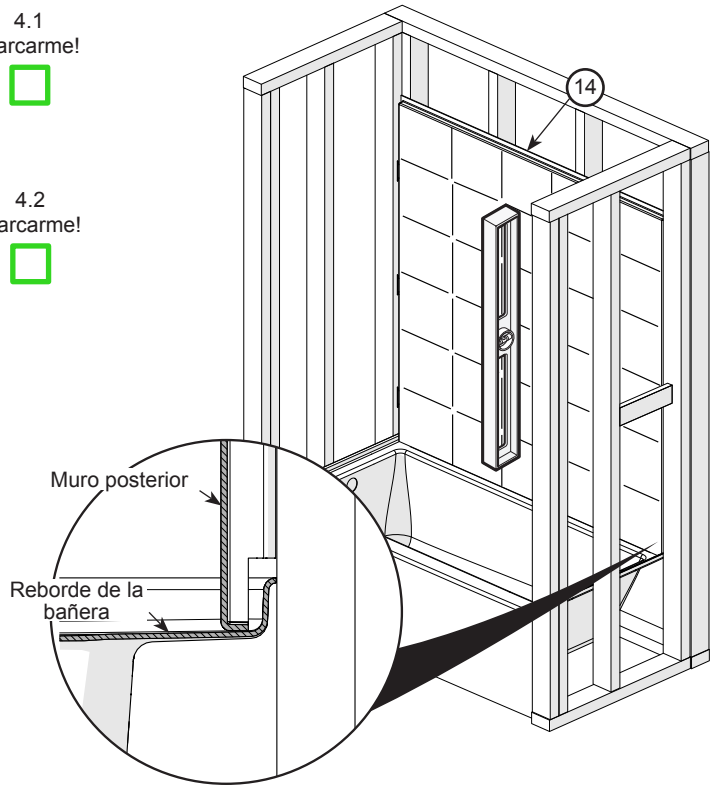

Perforar los pre-agujeros de la brida del muro posterior solamente con una broca de 1/8" alineando con cada montante. **No perforar los montantes.** Fijar el muro temporalmente a un montante usando un tornillo # 8 x 1 3/4" (no incluido).

IMPORTANTE: APRETAR A MANO ÚNICAMENTE! INSTALACIÓN TEMPORAL.

Consejo rápido



Empuje la parte inferior del muro contra los montantes con el pie en el momento de atornillar el muro en su lugar.

4.3 Marcarme!



min. 3/16"
max. 3/8"

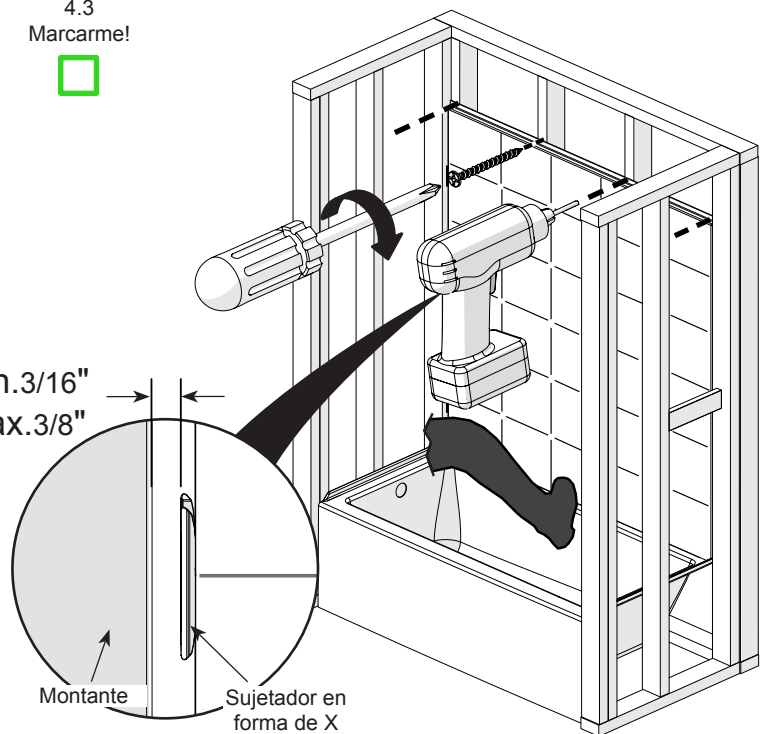

ETAPA 5

Instalación temporal de los muros laterales

Instalar el primer muro lateral (15) en el lado opuesto de la válvula. Coloque el muro aproximadamente 3 pulgadas por encima del reborde de la bañera, empujando con fuerza contra el muro posterior, a continuación, bajar el muro sobre el reborde de la bañera.

5.1
Marcarme!

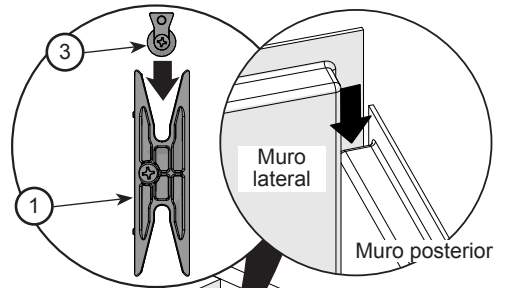

Es esencial que los pasadores estén completamente insertados en los sujetadores en X. No debe haber ningún espacio entre el muro lateral y el muro posterior.

Consejo rápido



El muro lateral debe estar alineado con la parte frontal de la bañera.

Consejo rápido



Comprobar la verticalidad de la pared lateral usando un nivel. Si la pared no es vertical, asegurarse que los pasadores de retracción están bien insertados en los sujetadores en forma de X.

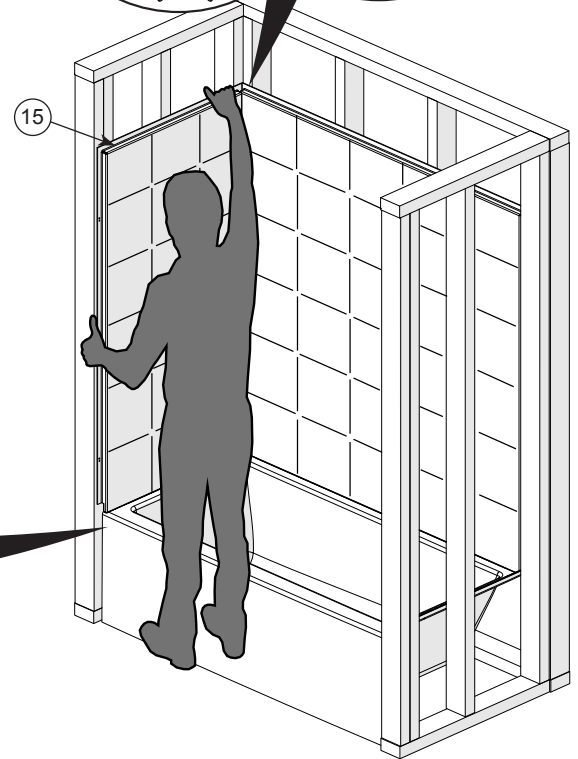
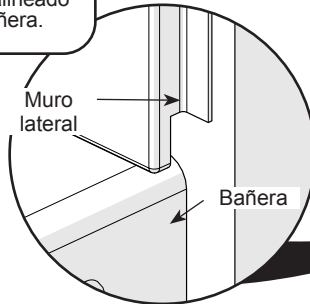

Perforar los pre-agujeros de la brida del muro lateral solamente (15), con una broca de 1/8" alineando con cada montante. **No perforar los montantes.** Fijar el muro temporalmente a un montante usando un tornillo # 8 x 1 3/4" (no incluido).

5.2
Marcarme!

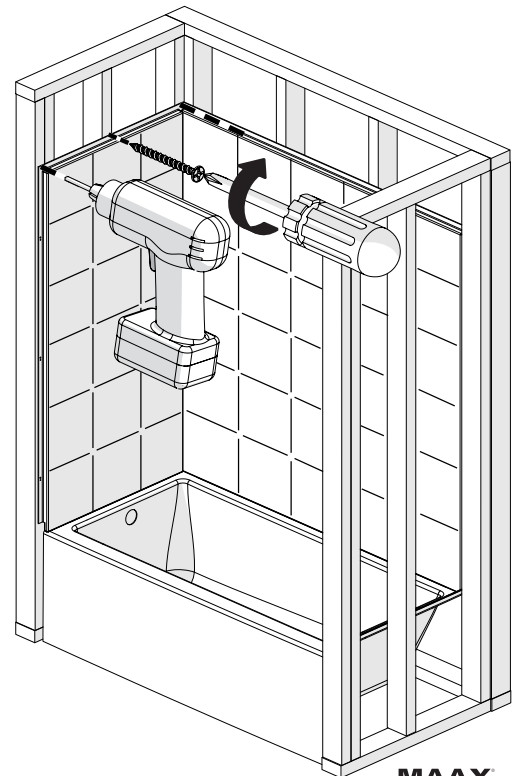

IMPORTANTE: APRETAR A MANO ÚNICAMENTE! INSTALACIÓN TEMPORAL.

5

Medir la distancia entre la cara del muro posterior y el centro de la válvula. Medir a continuación la distancia entre el reborde de la bañera y el centro de la válvula.

Pasar las medidas de la posición del hueco de la válvula y marcar sobre el muro lateral que aun no ha sido instalado. Medir a partir de la parte inferior del muro y del lado de los pasadores de retracción. Repetir esta etapa para cada hueco de válvula.

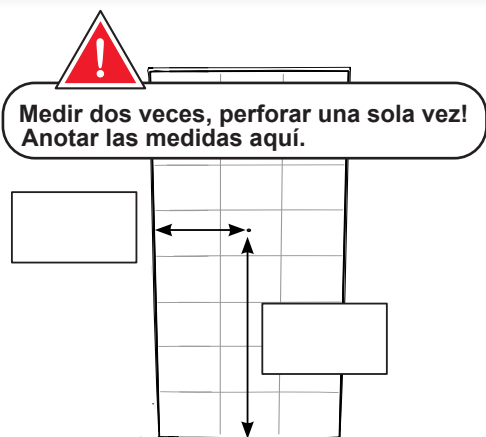

5.3
Marcarme!



5.4
Marcarme!

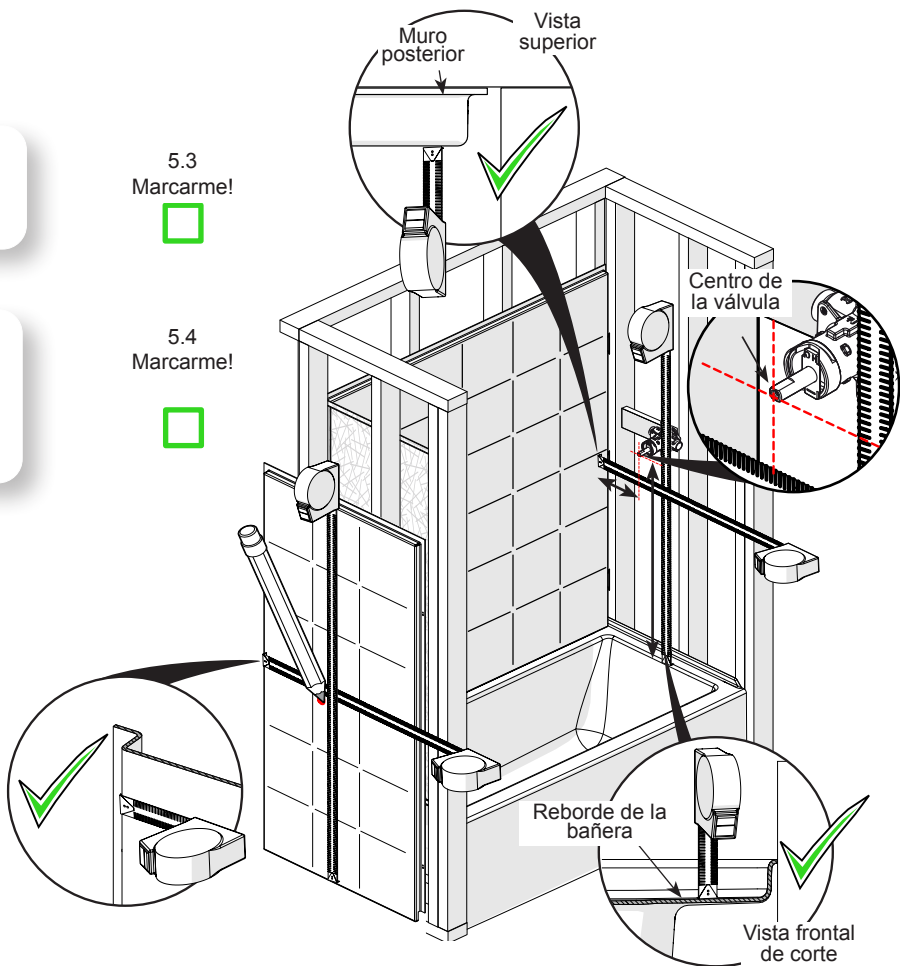

Perforar desde el frente los huecos para las válvulas: Hacer primero una pre perforación con una broca de 1/8". Usar una sierra de perforación para perforar el orificio de la válvula en el sitio marcado. Consultar la guía de instalación de la válvula para conocer el tamaño apropiado de la sierra de perforación.

Consejo rápido



Las sierras de perforación pueden ser alquiladas en las ferreterías o en los locales de alquiler de herramientas.

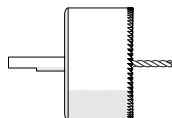

Para una perforación segura: Pre-perforar siempre los agujeros y usar gafas de seguridad.

5.5
Marcarme!

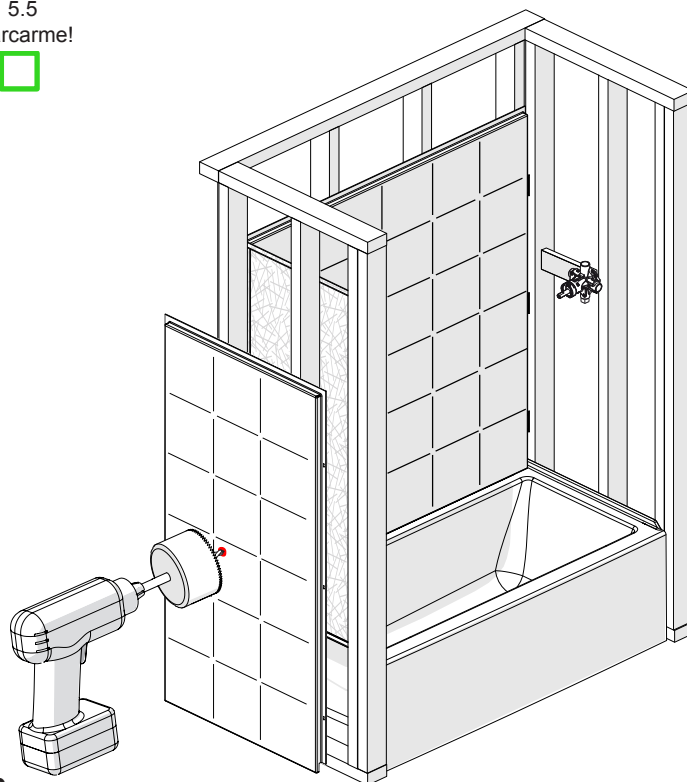

ETAPA 5 Instalación temporal de los muros laterales (continuación)

Instalar el muro lateral (15) una vez los agujeros de la válvula han sido perforados. Coloque el muro aproximadamente 3 pulgadas por encima del reborde de la bañera, empujando con fuerza contra el muro posterior, a continuación, bajar el muro sobre el reborde de la bañera.

5.6 Marcarme!

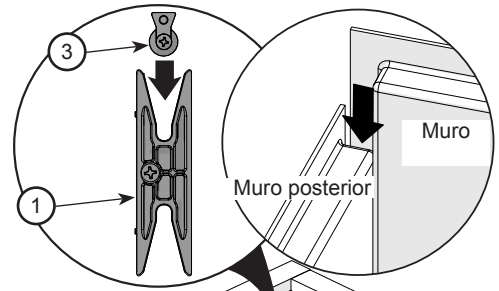

!
Es esencial que los pasadores estén completamente insertados en los sujetadores en X. No debe haber ningún espacio entre el muro lateral y el muro posterior.

Consejo rápido



El muro lateral debe estar alineado con la parte frontal de la bañera.

Consejo rápido



Comprobar la verticalidad de la pared lateral usando un nivel. Si la pared no es vertical, asegurarse que los pasadores de retracción están bien insertados en los sujetadores en forma de X.

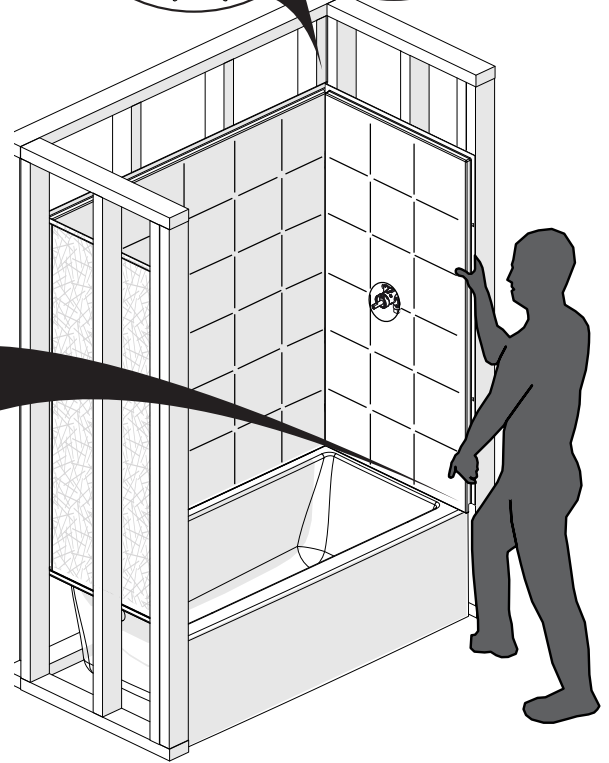
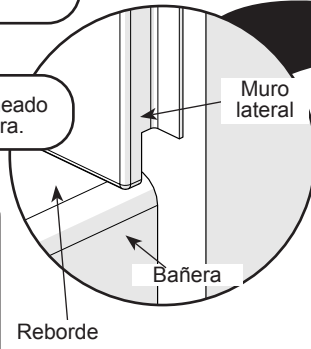

Perforar los pre-agujeros de la brida del muro lateral solamente (15), con una broca de 1/8" alineando con cada montante. **No perforar los montantes.** Fijar el muro temporalmente a un montante usando un tornillo # 8 x 1 3/4" (no incluido).

5.7 Marcarme!



IMPORTANTE: APRETAR A MANO ÚNICAMENTE! INSTALACIÓN TEMPORAL.

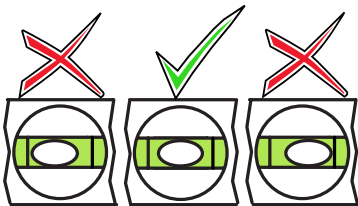
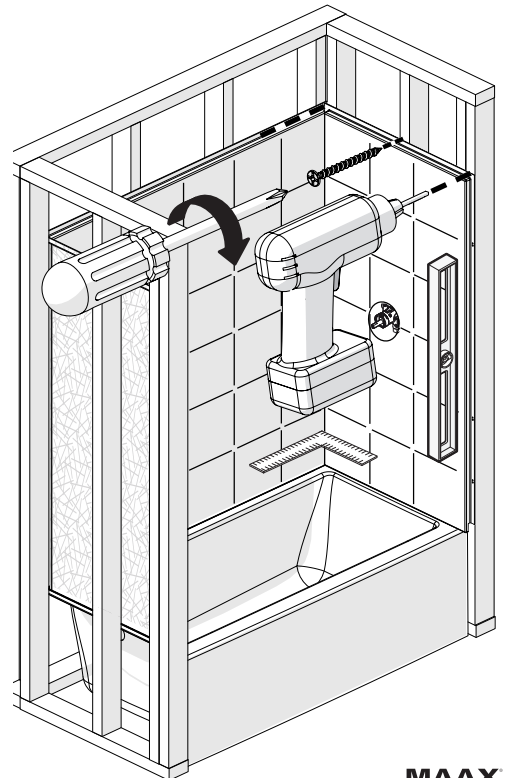

!
ANTES DE CONTINUAR, ASEGURARSE QUE TODOS LOS MUROS ESTÁN A ESCUADRA Y VERTICALES.

5.8 Marcarme!



ETAPA 6 Instalación final del muro posterior

Retirar todos los muros de la estructura.

Limpia la base y aplica una línea de silicona en el borde de la bañera a 3/8" de la brida trasera. Aplica silicona sobre toda la longitud trasera y alrededor de 1 pulgada por lado.

Levanta y coloca en su lugar el muro posterior (sin deslizarlo) directamente sobre la silicona. Asegúrate que el muro posterior (14) está a nivel, agrega cuñas de madera en caso de ser necesario. Fija el muro a todos los montantes con tornillos #8 x 1-3/4" (no incluidos).

IMPORTANTE: APRETAR A MANO ÚNICAMENTE! INSTALACIÓN TEMPORAL.



Para asegurar la instalación de los muros laterales, debe haber un espacio mínimo de 3/16" y un máximo de 3/8" entre los montantes y los sujetadores en X.

Consejo rápido



Empuje la parte inferior del muro contra los montantes con el pie en el momento de atornillar el muro en su lugar.

De cada lado de la bañera (13) aplica una línea de silicona sobre toda la longitud del borde, a 1/4" de la brida. Aplica también una línea de silicona de arriba hasta abajo del muro posterior (14), sobre la superficie frontal y al borde redondeado. **En la unión entre el muro posterior y la bañera las líneas de silicona deben encontrarse.**

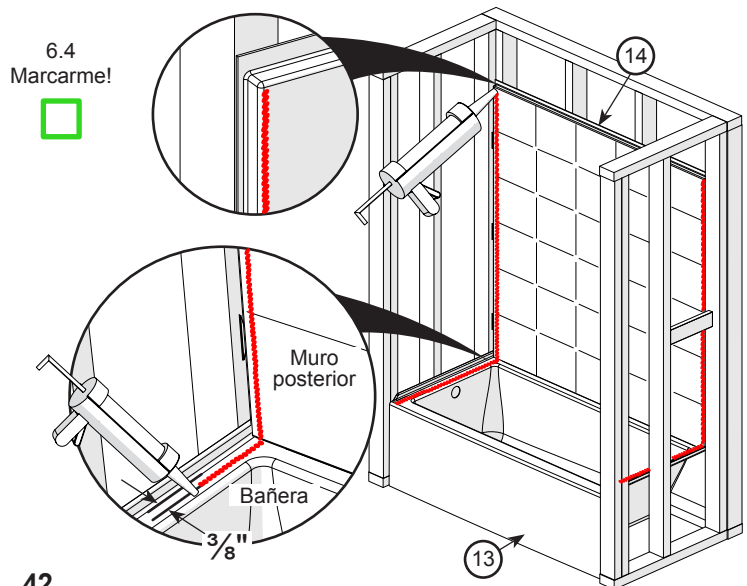
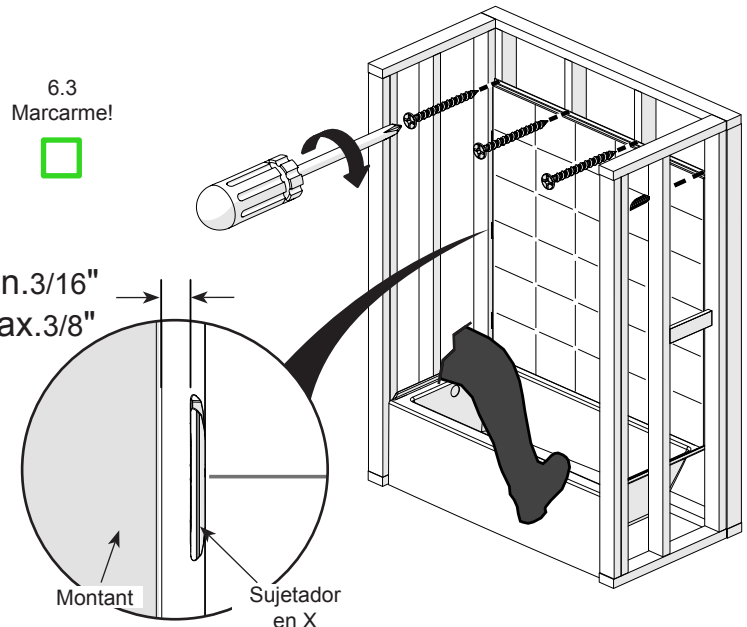
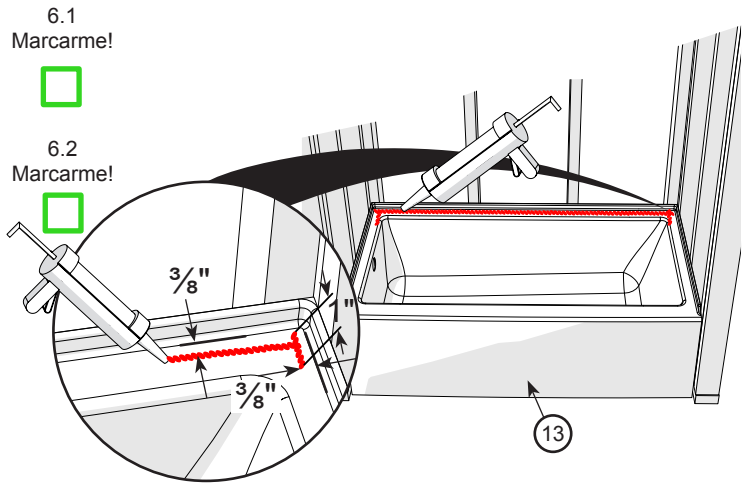

ETAPA 7 Instalación final de los muros laterales

Instalar el muro lateral (15) opuesto al de la válvula. Poner el muro a aproximadamente 3" por encima del reborde de la bañera, empujarlo a fondo contra el muro posterior y descenderlo sobre el reborde de la bañera.

RETIRAR EL EXCESO DE SILICONA.

7.1 Marcarme!

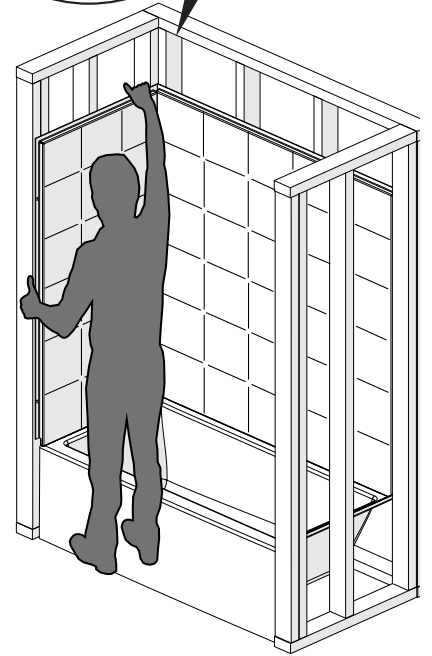
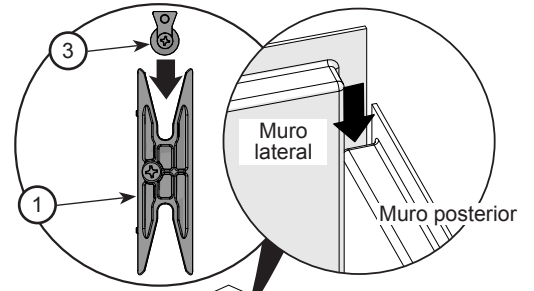

Instalar el muro lateral (15) que tiene los agujeros de la válvula. Poner el muro a aproximadamente 3" por encima del reborde de la bañera, empujarlo a fondo contra el muro posterior y descenderlo sobre el reborde de la bañera.

RETIRAR EL EXCESO DE SILICONA.

7.2 Marcarme!

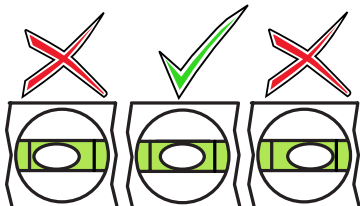
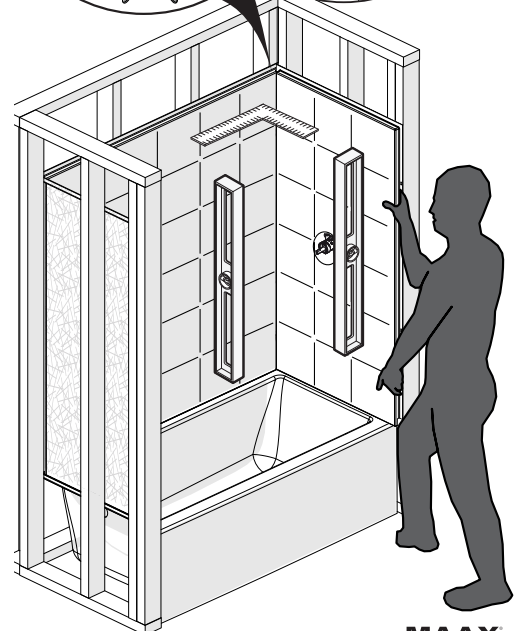
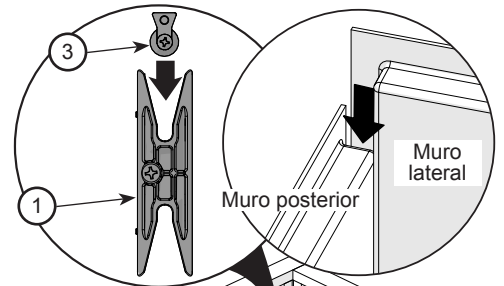

ANTES DE CONTINUAR, ASEGURARSE QUE TODOS LOS MUROS ESTÁN A ESCUADRA Y VERTICALES.

7.3 Marcarme!



ETAPA 7 Instalación final de los muros laterales (continuación)

Fijar los muros laterales a todos los montantes con tornillos #8 x 1-3/4" (no incluidos). Asegurar los muros utilizando los agujeros pre-perforados de la brida. En caso de ser necesario, usar cuñas de madera para asegurarse que los muros están a nivel y verticales. (Cortar el exceso de cuñas)

IMPORTANTE: APRETAR A MANO UNICAMENTE. NO APRETAR DEMASIADO LOS TORNILLOS.

Consejo rápido



LOS MUROS LATERALES TIENEN QUE ESTAR BIEN ALINEADOS CON EL FRENTE DE LA BAÑERA

Muro lateral

Bañera

7.4
Marcarme!

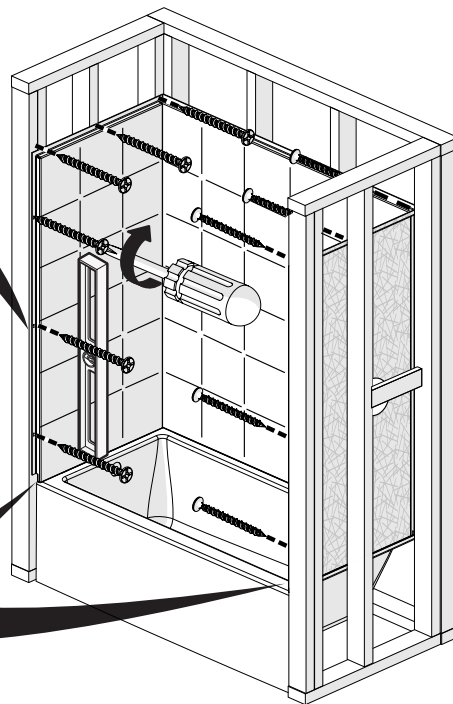
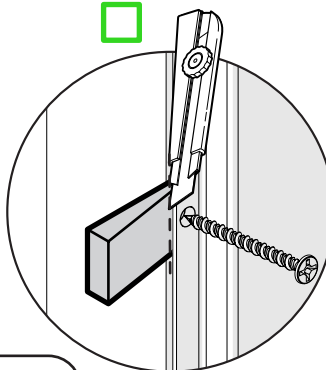

ETAPA 8 Marcado y la perforación de agujeros para la repisa

Poner la plantilla de perforación en la esquina de la ducha, en la ubicación deseada. deslizar la plantilla hasta que los agujeros estén a la altura deseada para la repisa. Marcar la ubicación de los agujeros para perforación. Perforar los agujeros con una broca de 6/64".

Marcarme!



Posiciones de perforación

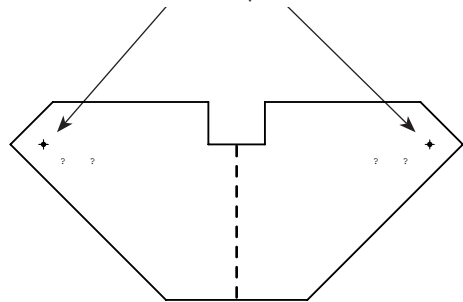

Plegar aquí

90°

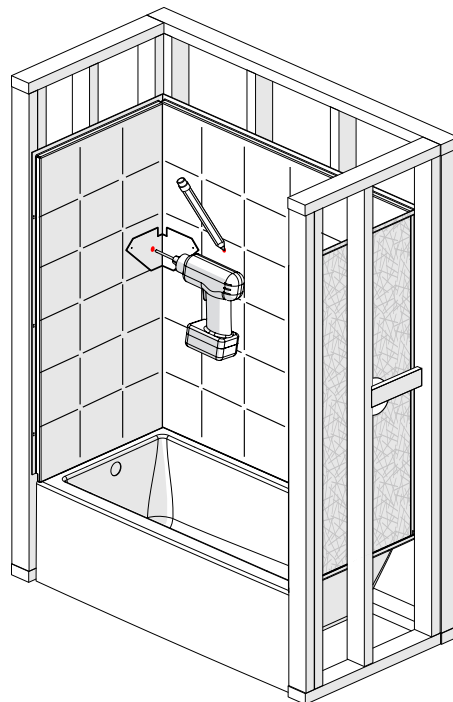
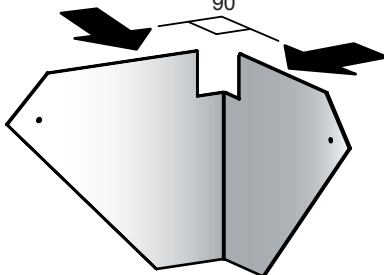

ETAPA 9 Silicona

Aplicar una línea de silicona sobre toda la longitud de las uniones (muro a muro y muro a bañera). Para un buen acabado, retirar el exceso de silicona con un trapo humedo o un dedo humedecido.

Consejo rápido



Aplicar cinta de enmascarar de cada lado de la unión donde la silicona será aplicada. Aplicar la silicona, emparejar con un dedo humedecido, a continuación retirar la cinta.

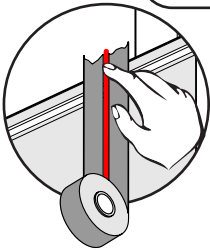

Toda grifería instalada sobre los muros debe ser sellada con silicona.

Marcarme!



Retirar la película de protección de los muros

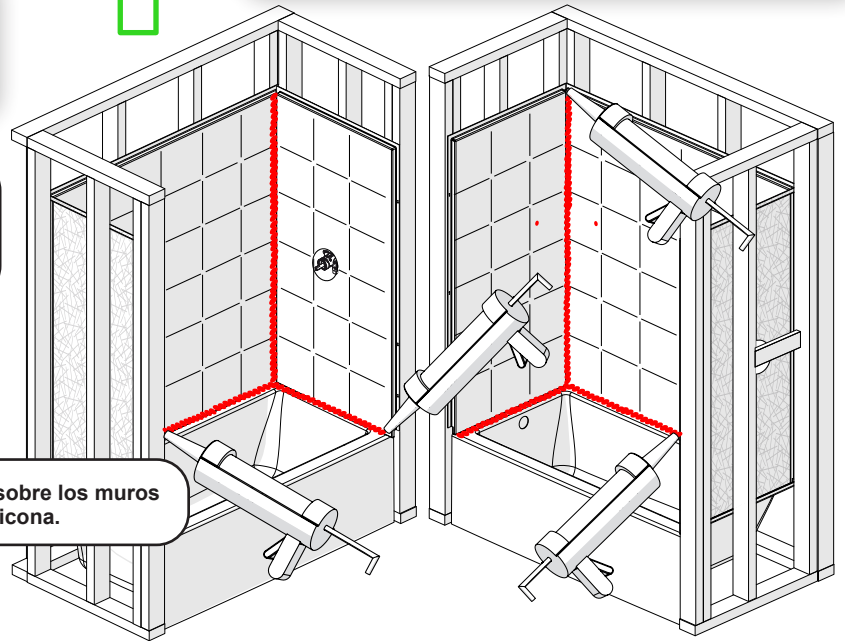

ETAPA 10 Instalación de la repisa

Aplicar silicona en los agujeros del muro lateral y del muro posterior que servirán para instalar la repisa. Aplicar silicona detras de los soportes de repisa (6). Fijar los soportes a los muros utilizando los tornillos suministrados (7).

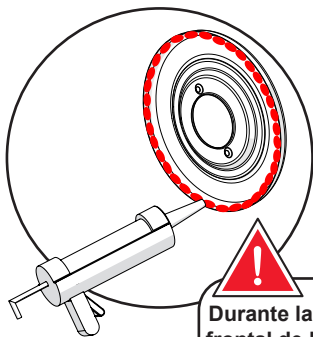

Durante la instalación de la placa frontal de la válvula o de otros componentes, aplicar silicona en el borde exterior.

10.1

Marcarme!

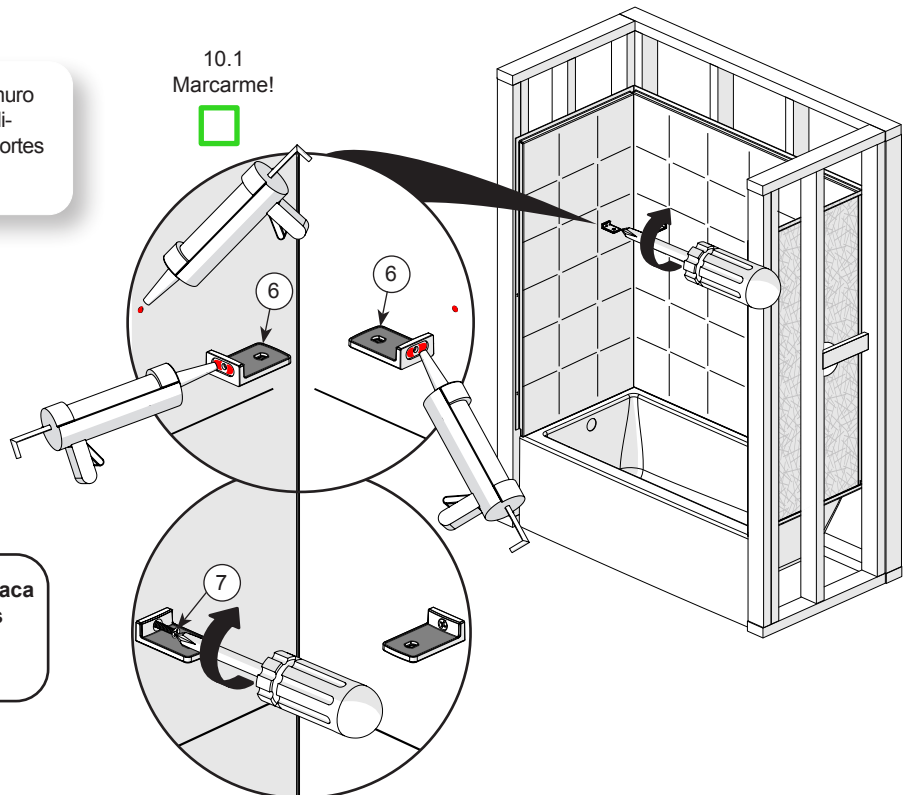

ETAPA 10 Instalación de la repisa (continuación)

Limpiar la parte en caucho por encima de los soportes con un trapo húmedo. Colocar a continuación la repisa (5) sobre los soportes (6).

Consejo rápido



La repisa está en la posición correcta si es posible leer el logo de MAAX.

10.2 Marcarme!

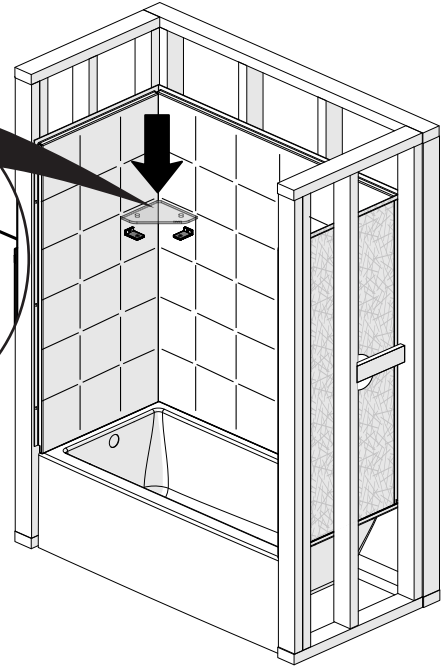
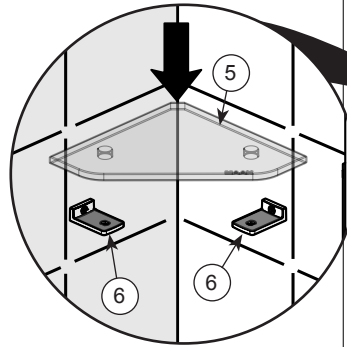

Insertar las tapas de fijación de la repisa (9) en las arandelas (8). Alinear los agujeros de la repisa y los de los soportes (6) e insertar el ensamblaje de la tapa (9). Bajo la repisa, insertar los tornillos #10 x 1/2" (10) y apretar con la llave allen (11).

10.3 Marcarme!

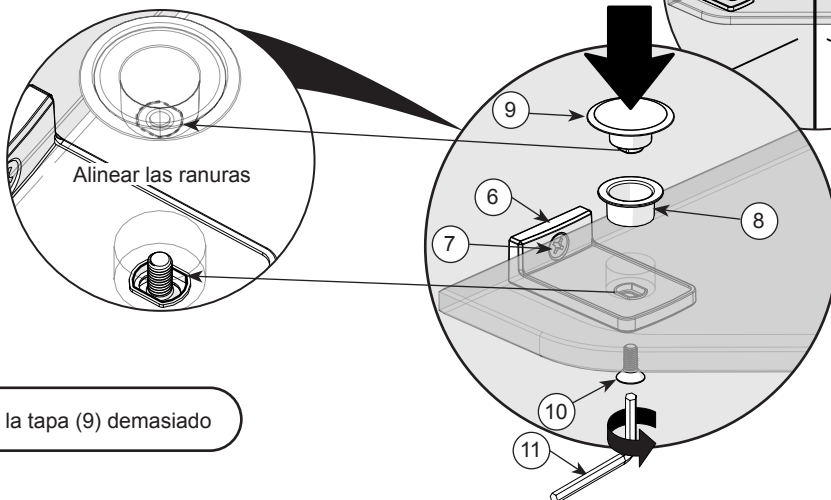

Alinear las ranuras

No apretar la tapa (9) demasiado

ETAPA 11 Acabado del muro

Para el acabado del muro, puede instalar su material de acabado sobre la parte superior de la brida o sobre el borde del muro, como se muestra.

Marcarme!

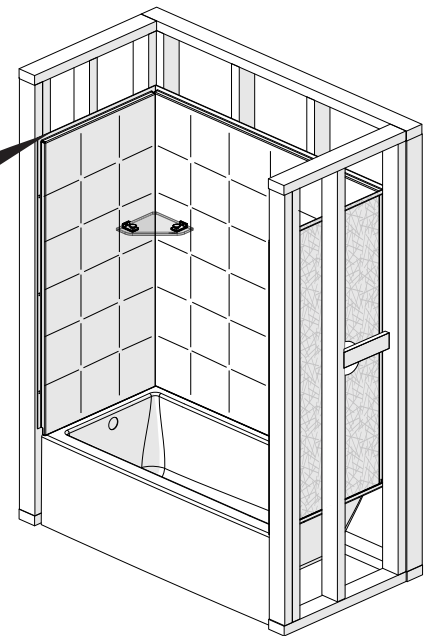
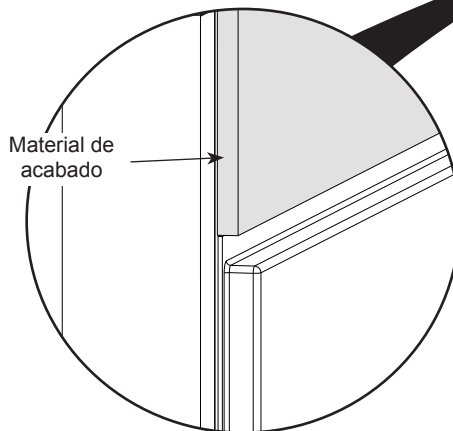
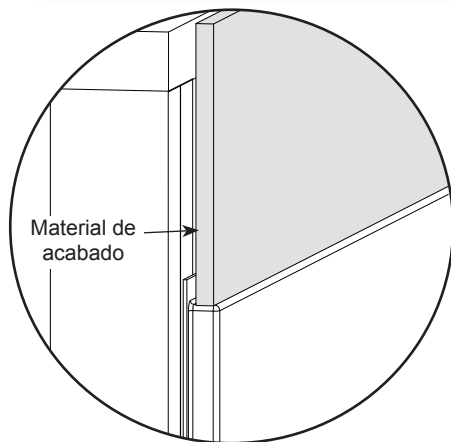

Consejos de mantenimiento

MAAX concibe y fabrica sus productos usando **materiales durables de alta calidad y con tecnologías de punta** con el fin de reducir el tiempo de limpieza y mantenimiento. Sin embargo, es esencial efectuar el mantenimiento de manera frecuente y adecuada.

He aquí algunas recomendaciones generales para el uso y mantenimiento, además de las recomendaciones específicas para su producto MAAX. Le recomendamos que las siga para proporcionar años de agradable uso.

Mantenimiento de los muros Utile / Bañera / base de ducha / puerta de ducha

- ☒ **Limpiar frecuentemente** con un limpiador en aerosol en crema no abrasivo.
- ☒ **Nunca usar limpiadores para cerámica o juntas de lechada.** Esos productos son inapropiados para los productos Utile y podrían dañar la unidad.
- ☒ **Nunca usar un limpiador abrasivo, un raspador, una esponjilla metálica** ni ninguna otra herramienta ou producto que pueda rayar o empañar la superficie de su unidad MAAX.
- ☒ Para evitar dañar el acabado de la unidad, retirar los **residuos de yeso** que podrían depositarse sobre las superficies después de efectuar trabajos con una espátula en plástico o en madera envuelta en un trapo humedo.
- ☒ **Secar la puerta de ducha después de cada uso** con una esponja o un trapo suave para reducir la acumulación de jabón, de aditivos de baño, de aceites corporales naturales y de minerales presentes en el agua. Esto facilitará la limpieza y ayudará a conservar el brillo natural de su producto.
- ☒ **Reparar las fisuras o daños inmediatamente** con la ayuda del kit de reparación MAAX para los productos Utile. Para más información, contactar el servicio a la clientela al **1-877-GET-MAAX (1-877-438-6229)**.



LIMITED WARRANTY — UNITED STATES

MAAX Bath Inc. offers express limited warranty on each of its products. This warranty extends only to the original owner/end-user for personal household use. For commercial uses, additional limitations apply.

For accessing product Limited warranty please visit:

<https://maax.com/services/warranty>

LIMITED WARRANTY — CANADA

MAAX Bath Inc. offers express limited warranty on each of its products. This warranty extends only to the original owner/end-user for personal household use. For commercial uses, additional limitations apply.

For accessing product Limited warranty please visit:

<https://maax.ca/services/warranty>

GARANTIE LIMITÉE — CANADA

MAAX Bath Inc. offre une garantie limitée expresse sur chacun de ses produits. Cette garantie s'adresse uniquement au propriétaire/utilisateur original pour un usage personnel domestique. Des restrictions additionnelles s'appliquent aux utilisations commerciales

Pour accéder à la garantie limitée de votre produit, veuillez consulter le site :

<https://maax.ca/fr-CA/services/garantie>

Vivez l'expérience
MAAX[®]
Enjoy the experience

Technical Services / Service technique / Servicio técnico

T. 1 877 GET-MAAX (1 877 438-6229)

F. 1 888 361-2045

www.maax.com